

# KNMI contribution to the WMO Laboratory Intercomparison of Rainfall Intensity Gauges

*Wiel Wauben*

*Instrumental Department, INSA-IO, KNMI*

April 18, 2006

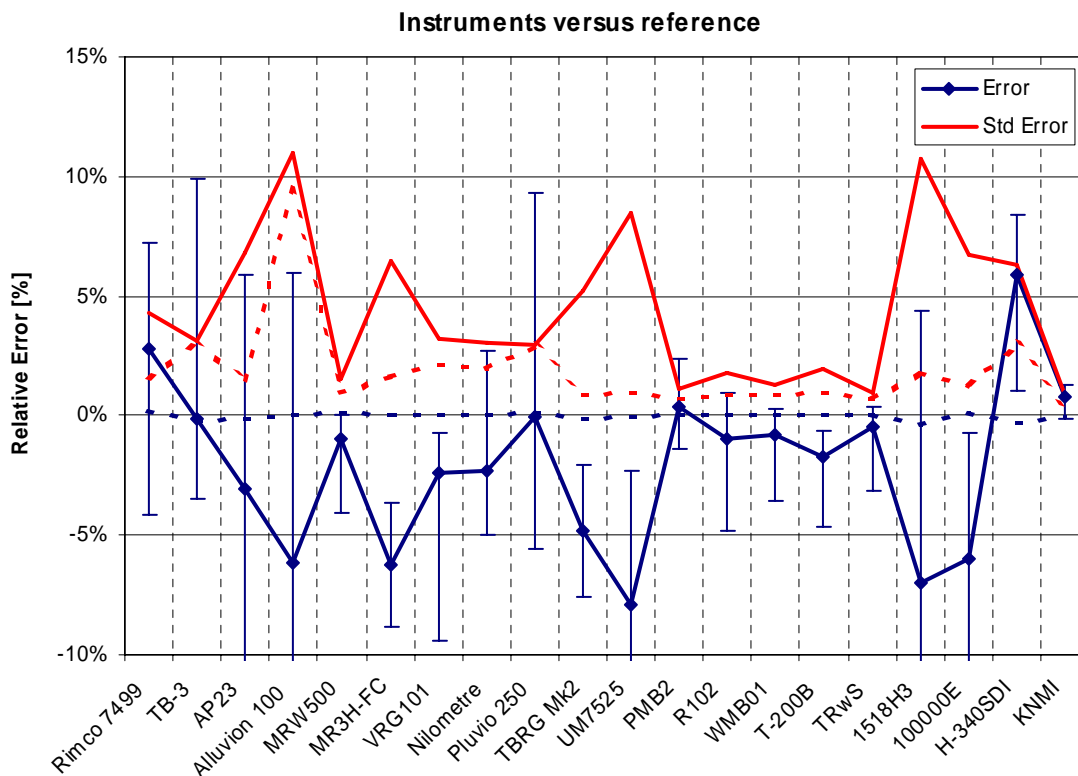



## Table of Contents

<b>1. Introduction.....</b>	<b>1</b>
<b>1.1. Background.....</b>	<b>1</b>
<b>1.2. This report.....</b>	<b>2</b>
<b>1.3. To the reader.....</b>	<b>2</b>
<b>2. Background to the laboratory intercomparison .....</b>	<b>4</b>
<b>2.1. Selection of instruments.....</b>	<b>4</b>
<b>2.2. Sensor characteristics .....</b>	<b>5</b>
<b>2.3. Test procedures.....</b>	<b>6</b>
<b>2.4. KNMI test setup .....</b>	<b>7</b>
<b>2.5. Measurement uncertainty of the KNMI test setup .....</b>	<b>12</b>
<b>2.6. Data analysis.....</b>	<b>15</b>
<b>3. Results and discussions .....</b>	<b>17</b>
<b>3.1. Mc Van Instruments Rimco 7499.....</b>	<b>17</b>
<b>3.2. Hydrological Services TB-3 .....</b>	<b>20</b>
<b>3.3. Anton Paar AP23 .....</b>	<b>22</b>
<b>3.4. Axys Environmental Syst. Alluvion 100 .....</b>	<b>24</b>
<b>3.5. Meteoservis MRW500.....</b>	<b>28</b>
<b>3.6. Meteoservis MR3H-FC.....</b>	<b>33</b>
<b>3.7. Vaisala VRG101 .....</b>	<b>37</b>
<b>3.8. Serosi Nilometre.....</b>	<b>40</b>
<b>3.9. Ott Hydrometrie Pluvio 250.....</b>	<b>46</b>
<b>3.10. India Meteorology Dept. TBRG Mk2.....</b>	<b>50</b>
<b>3.11. SIAP UM7525.....</b>	<b>52</b>

3.12. CAE PMB2.....	55
3.13. ETG R102 .....	58
3.14. Yokogawa Denshi Kiki Co. WMB01.....	63
3.15. Geonor T-200B.....	66
3.16. MPS System TRwS.....	69
3.17. Lambrecht 1518H3.....	73
3.18. Casella CEL Ltd. 100000E.....	75
3.19. Design Analysis Ass. H-340SDI.....	78
3.20. KNMI Neerslagmeter .....	81
<b>4. Summary, conclusions and recommendations.....</b>	<b>90</b>
4.1. Summary.....	90
4.2. Conclusions and recommendations.....	96
4.3. Conclusions KNMI Neerslagmeter .....	98
<b>5. References and acknowledgements.....</b>	<b>100</b>
5.1. References .....	100
5.2. Acknowledgements.....	100
<b>Appendix 1: Rimco 7499.....</b>	<b>101</b>
<b>Appendix 2: TB-3.....</b>	<b>104</b>
<b>Appendix 3: AP23.....</b>	<b>107</b>
<b>Appendix 4: Alluvion 100.....</b>	<b>109</b>
<b>Appendix 5: MRW500.....</b>	<b>112</b>
<b>Appendix 6: MR3H-FC.....</b>	<b>116</b>

<b>Appendix 7: VRG101 .....</b>	<b>120</b>
<b>Appendix 8: Nilometre .....</b>	<b>123</b>
<b>Appendix 9: Pluvio 250 .....</b>	<b>126</b>
<b>Appendix 10: India Meteorology Dept. TBRG Mk2 .....</b>	<b>129</b>
<b>Appendix 11: SIAP UM7525 .....</b>	<b>132</b>
<b>Appendix 12: CAE PMB2 .....</b>	<b>135</b>
<b>Appendix 13: ETG R102 .....</b>	<b>139</b>
<b>Appendix 14: Yokogawa Denshi Kiki Co. WMB01 .....</b>	<b>143</b>
<b>Appendix 15: Geonor T-200B .....</b>	<b>146</b>
<b>Appendix 16: MPS System TRwS .....</b>	<b>149</b>
<b>Appendix 17: Lambrecht 1518H3 .....</b>	<b>152</b>
<b>Appendix 18: Casella CEL Ltd. 100000E .....</b>	<b>155</b>
<b>Appendix 19: Design Analysis Ass. H-340SDI.....</b>	<b>158</b>
<b>Appendix 20: KNMI Neerslagmeter.....</b>	<b>161</b>



# 1. Introduction

## 1.1. Background

The Commission for Instruments and Methods of Observation (CIMO-XII Casablanca, 1998) of the World Meteorological Organization (WMO) discussed the need for standardization of rainfall intensity measurements and considered the need and possibility of a Rainfall Intensity Measurement Intercomparison. These issues were addressed during the Expert Meeting (EM) on Rainfall Intensity Measurements held in Bratislava, Slovak Republic, 23-25 April 2001. The meeting focused on rain intensity only. The Expert Meeting discussed the advantages and disadvantages of the various performance characteristics of different measuring techniques used for rainfall intensity measurements and concluded that only *in situ* catchment type gauges should be considered further. This because this type of sensors is the most practical and widely used in operational networks for rainfall intensity measurements and, in addition, laboratory and field intercomparisons of these gauges are considered to be feasible. The Expert Meeting agreed that the calibration of rainfall intensity gauges was the primary and most stringent task. Calibration techniques for catchment type gauges have been described in the literature, but at the present there is no standardized calibration equipment or procedure suitable for general application. Therefore the development and testing of a standardized calibration technique has to be developed first in well-certified laboratories. Furthermore, the laboratory tests of the rainfall intensity gauges should be performed in at least two independent certified laboratories. The Expert Meeting recognized that there was a particular need to compare gauges for high rainfall intensity rates, since the general performance characteristics of various types of rain gauges had been sufficiently tested for low intensities at various national and international intercomparisons. Taking into account the difficulties related to organizing and conducting a field intercomparison in a climatic region with the required high rainfall intensities during a comparison period and the unavailability of suitable and recognized reference instruments, it was agreed to start first with a laboratory intercomparison on rainfall intensity gauges. A decision towards a field intercomparison should then be made based on the results of the initial laboratory comparison.

Based on the recommendations of the Expert Meeting an International Organizing Committee (IOC) was established by the President of CIMO for the organization and conduction of the rainfall intensity intercomparison. A joint meeting of the Expert Team (ET) on Surface-Based Instrument Intercomparisons and Calibration Methods (SBII&CM) and the IOC was held in Trappes, France, 24-28 November 2003. During this meeting the laboratories of the Department of Environmental Engineering (DIAM) of the University of Genoa, Météo France and the Royal Netherlands Meteorological Institute (KNMI) were proposed as potential candidate laboratories for the intercomparison and found suitable by the ET/IOC after examination. The main objective of the laboratory intercomparison is to test the performance of catchment type rainfall intensity gauges of different measuring principles under documented conditions. Some further objectives are (i) to define a standardized procedure for laboratory calibration of catchment type of rainfall intensity gauges; (ii) to evaluate the performance of the

instruments under test; and (iii) to provide information on different measurement systems relevant to improving the homogeneity of rainfall time series with special consideration given to high rainfall intensities. The ET/IOC, in addition to the general rules and procedures for WMO Intercomparisons as defined in the Guide to Instruments and Methods of Observation, WMO - No.8, Part III, Chapter 5, Annex 5.A and 5.B, agreed upon specific rules and procedures, which are described in the final report of that meeting and will also be given in this report. The requirements for rainfall intensity measurements recommended by CIMO XIII and published in the CIMO Guide (1996) are:

- (1) a time resolution of 1 minute;
- (2) a measuring range of 0.02 to 2000 mm/h; and
- (3) uncertainties of 5 % for intensities between 2 and 2000 mm/h; uncertainties of 0.1 mm/h for intensities between 0.2 and 2 mm/h and precipitation detection for traces of precipitation with intensities between 0.02 and 0.2 mm/h.

## **1.2. This report**

This report presents the results of the laboratory intercomparison of rainfall intensity gauges obtained by KNMI. The KNMI results are also included in the final report of the ET/IOC (Lanza et al., 2006) on this intercomparison where the results are compared to that obtained by the other 2 laboratories involved. It should be noted that the results of sensors 4, 14 and 15 presented here differ slightly from the WMO results since a different value for evaporation was adopted. In this report more details will be given on the set-up and results obtained at KNMI. In addition to the averaged error curves that are also reported in the WMO final report, details of the data analysis, including the behavior of the sensor results on a 1-minute time scale, are presented. This leads to a better understanding of the sensor capabilities regarding rainfall intensity measurements. Furthermore, the results after correction of the results by a second order polynomial and a power law fit are given and the summary of the results is performed using the error curves instead of the focus on the power law fit in the final report. Finally, results of the KNMI precipitation gauge, which did not participate in the WMO intercomparison, are presented. The KNMI precipitation gauge was included in the KNMI test in order to be able to compare the performance of the KNMI sensor to the sensors considered in the WMO test. The report also contains many comments on the sensors that are the result of “hands-on” experience with the sensors. Unfortunately, the author was not personally involved in the testing of the first batch of sensors at KNMI so that any comments on these sensors are based on “hear-say” or have been extracted from the results and/or documentation.

## **1.3. To the reader**

A report that describes the results of tests for 20 different sensors and wants to show details is long and bound to contain duplications. Describing the results of each sensor individually is a tedious job and the reader might easily get bored. Therefore a reader that does not need to know all the details should consider reading one results section for each type of sensor (tipping bucket, weighing and water level) in order to get a feeling of the issues involved. The summary and recommendations section gives a concise overview of the performance of each sensor. The reader can also focus on the type of sensor that is used in her/his meteorological network. The reader should note that the error results in

this report are obtained from laboratory tests, but another crucial requirement is the performance of the sensors in operational conditions. This will be investigated in an upcoming WMO field test of rainfall intensity gauges.

## 2. Background to the laboratory intercomparison

These sections give detailed background information on various aspects of the laboratory intercomparison of rainfall intensity gauges.

### 2.1. Selection of instruments

The ET/IOC decided that the laboratory intercomparison of rainfall intensity gauges was restricted to *in situ* catchment type gauges since this type of sensors is widely used in operational networks for rainfall intensity measurements and a laboratory intercomparison of this type of gauges is considered to be feasible. Furthermore, only instruments that are capable of measuring rainfall intensities of at least 200 mm/h at a time resolution of 1 minute were considered. In addition, the instruments should have a digital output (serial or pulse) so that a PC can easily acquire the data. An appropriate interface should be provided in case the instrument has another type of output. Preference was given to instruments with an uncertainty less than 5 % over the range of the measurements as recommended by WMO and sensors that are being used in national networks or are being considered for use in such networks. To achieve more confidence in the results, 2 instruments of each type are generally tested. Due to limited resources, the number of participating instruments was initially limited to a maximum of twelve pairs of gauges. However, given the higher demand and based on the proposal of the project leader, the ET/IOC had selected nineteen instruments out of the 28 sensors proposed by the member countries and the Association of Hydrological and Meteorological Equipment Industry (HMEI), based on the following criteria:

- Instruments are to be selected in a way to cover a variety of measurement techniques;
- Preference should be given to new promising measuring techniques;
- Preference should be given to instruments that are widely in use in member countries.

The list of selected instruments is recalled in Table 1. The list includes also the KNMI precipitation gauge that was not part of the WMO laboratory intercomparison of rainfall intensity gauges. The KNMI precipitation sensor was subjected to the same tests, albeit only at the laboratory of KNMI, in order to learn how the sensor performs compared to the other instruments. The table gives the manufacturer and model/type of the rainfall intensity gauges. The table shows that most sensors considered in the test are of the tipping bucket type, which is the most common type of gauge used worldwide. A tipping bucket rain gauge consists of a tipping balance with two buckets as the measuring element. The balance tips whenever a fixed amount of water has been accumulated in one of the buckets. During the tip a reed contact is closed and registered by the acquisition system. The tip empties the filled bucket and places the other bucket underneath the collecting funnel. The 2 other measurement principles considered in this test measure the amount of precipitation by the change of the water level in a reservoir or by the change of mass of the collector. The number of instruments submitted to the test, generally 2, is also indicated. The last column denotes the laboratory where the rainfall intensity gauges was first tested. At KNMI the NL batch was tested first, followed by the IT batch and next the FR batch of instruments, and last the KNMI instrument.

Table 1: List of the 19 instruments selected for the WMO Laboratory Intercomparison of Rainfall Intensity Gauges and the KNMI precipitation gauge.

No.	Country – Manufacturer	Model/Type	Measurement Principle	Number of Instruments	Batch
1	Australia – Mc Van Instruments	Rimco 7499	Tipping Bucket	2	NL
2	Australia – Hydrological Services	TB-3	Tipping Bucket	2	NL
3	Austria – Anton Paar	AP23	Tipping Bucket	1	FR
4	Canada – Axys Environmental Syst.	Alluvion 100	Water Level	2	NL
5	Czech Republic – Meteoservis	MRW500	Weighing	2	IT
6	Czech Republic – Meteoservis	MR3H-FC	Tipping Bucket	2	IT
7	Finland – Vaisala	VRG101	Weighing	2	NL
8	France – Serosi	Nilometre	Water Level	2	FR
9	Germany – Ott Hydrometrie	Pluvio 250	Weighing	2	FR
10	India – India Meteorology Dept.	TBRG Mk2	Tipping Bucket	2	FR
11	Italy – SIAP	UM7525	Tipping Bucket	2	IT
12	Italy – CAE	PMB2	Tipping Bucket	2	IT
13	Italy – ETG	R102	Tipping Bucket	2	IT
14	Japan – Yokogawa Denshi Kiki Co.	WMB01	Tipping Bucket	2	NL
15	Norway – Geonor	T-200B	Weighing	2	NL
16	Slovakia – MPS System	TRwS	Weighing	2	IT
17	Switzerland – Lambrecht	1518H3	Tipping Bucket	2	FR
18	United Kingdom – Casella CEL Ltd.	100000E	Tipping Bucket	2	FR
19	USA – Design Analysis Ass.	H-340SDI	Tipping Bucket	1	FR
20	Netherlands – KNMI	Neerslagmeter	Water Level	2	–

## 2.2. Sensor characteristics

Details for each sensor can be found in the results and discussion section as well as in the documentation provided by the manufacturer. Table 2 reports the main characteristics of the rainfall intensity gauges. For each instrument the area of the orifice, the resolution, the maximum intensity and the delay are listed. The resolution is either determined by the volume of a bucket of the tipping bucket gauge in relation with the orifice area, or the output resolution of the sensor. The maximum intensity is taken from the data sheet of the manufacturer. Some sensors showed storage of water in the collecting funnel at intensities below the maximum intensity. An asterisk denotes these sensors, although in all cases the storage stabilized, i.e. it did not continue to grow, which would eventually lead to an overflow of the collector. Table 2 also gives the delay of the sensor that is related to the resolution of the sensor, but in addition an internal software algorithm or the output refresh rate of the sensor may affect it. In case of a tipping bucket sensor the reported delay is the time required to fill 2 buckets, and depends on intensity. For a tipping bucket gauge with a resolution of 0.2 mm the delay is 0.2 h=12 min at 2 mm/h. The last column in Table 2 indicates whether a raw signal (reed pulse, level or weight) is reported by the sensor or whether any processing (averaging, filtering or correction) is applied. Furthermore, the column gives some information on the sensor, mainly related to

the mechanical construction and the capacity of the sensor. It should be noted that all tipping bucket rain gauges empty automatically and can be operated continuously.

Table 2: Main characteristics of the rainfall intensity gauges considered in the WMO Laboratory Intercomparison and the KNMI precipitation gauge.

No.	Gauge	Orifice area (cm <sup>2</sup> )	Resolution (mm)	Maximum intensity (mm/h)	Delay	Remarks
1	Rimco 7499	323.7	0.2	500*	0.6/I h	Siphon controlled input, Raw pulse output
2	TB-3	314.2	0.2	700	0.8/I h	Siphon controlled 0.4 mm input, Raw pulse output
3	AP23	500.0	0.1	720*	0.2/I h	Raw pulse output
4	Alluvion 100	98.5	0.2	300	1.2/I h	Reservoir siphoned every 1.2 mm, Raw pulse output
5	MRW500	500.0	0.1	400	20 s	Open 100 mm reservoir is siphoned, Weight is processed
6	MR3H-FC	500.0	0.1	500*	0.2/I h	Raw and corrected pulse output
7	VRG101	400.0	0.01	2000	7 min	Open 750 mm reservoir, Weight is processed
8	Nilometre	400.0	0.01	200	2 min	7 mm reservoir is siphoned, Raw level output
9	Pluvio 250	200.0	0.01	1200	8 min	Open 250 mm reservoir, Weight is processed
10	TBRG Mk2	324.3	0.5	2000	1.0/I h	Raw pulse output
11	UM7525	1000.0	0.2	300	0.4/I h	Sphere prevents water leaving collector during tip, Raw pulse output
12	PMB2	1000.0	0.2	300	0.4/I h	Correction is applied
13	R102	1000.0	0.2	300	0.4/I h	Correction is applied
14	WMB01	314.2	1.0	200**	2.0/I h	Intensity output derived from pulse
15	T-200B	200.0	0.01*	600	20 s	Open 600 mm reservoir, Raw weight output
16	TRwS	500.0	0.001	600	3 min*	Open 220 mm reservoir, Weight is processed
17	1518H3	200.0	0.1	600	0.2/I h	Raw pulse output
18	100000E	400.0	0.2	500	0.4/I h	Raw pulse output
19	H-340SDI	324.3	0.254	635	0.508/I h	Intensity output derived from pulse
20	KNMI	400.0	0.006	300	36 s	10 mm reservoir is emptied, Level is processed

\*\* Unfortunately the WMB01 sensor was tested at KNMI only up to 200 mm/h, whereas it turned out later that the range of the sensor goes up to 2000 mm/h.

### 2.3. Test procedures

The Intercomparison of RI gauges were conducted at the recognized laboratories under the supervision of the Site Managers appointed by the host laboratories. All three laboratories involved in the WMO Laboratory Intercomparison of RI Gauges tested the performances of each of 19 types of rain gauges, with usually 2 instruments of the same

type. That means that about 6 types have been calibrated in each laboratory during a period of about 3 months and then the instruments were shifted from one laboratory to another one, for a new period of 3 months and so forth until all instruments have been tested in all laboratories. The tests were conducted between September 2004 and September 2005.

For each of the instruments involved in the intercomparison, each laboratory performed five tests. Each test was performed at least at seven reference intensities. However, since the higher rainfall intensities are of utmost importance for this intercomparison, the whole range of operation declared by the manufacturer was also investigated. Hence it was agreed that:

- Seven reference intensities levels are fixed at (around) 2, 20, 50, 90, 130, 170, 200 mm/h.
- If the maximum intensity reported by the manufacturer is higher than 200 mm/h, three further reference intensities are determined between 200 mm/h and the maximum intensity by dividing this range logarithmically into three parts.

The reference intensity should be obtained within the following limits:

- 2 mm/h level within 1.5 – 4 mm/h
- 20 mm/h level within 15 – 25 mm/h
- at higher intensities  $\pm 10\%$

For each test the following environmental parameters were noted and recorded before and after the test:

- Date and time;
- Ambient temperature [ $^{\circ}\text{C}$ ];
- Ambient relative humidity [%];
- Water temperature [ $^{\circ}\text{C}$ ];
- Atmospheric pressure [hPa].

## **2.4. KNMI test setup**

The test setup at KNMI consisted of 2 electronic scales and 2 peristaltic pumps connected to a PC. The pumps are used to generate a constant flow of water that is pumped from a reservoir into the instrument under test. The reservoir is located on a scale so that the reference intensity can be determined from the decrease of the weight of the reservoir over time. One pump is used for the low intensities whereas the other is used for the middle and high intensities. Tuning the speed of the pump and the diameter of the tubes controls the flow rate. Of the 2 scales generally only one is used for test practices since water is only pumped from one reservoir. The second reservoir/scale is used to determine the rate of evaporation. However, at high intensities both reservoirs/scales are used in order to be able to generate a constant flow during the required period. The PC is not only used to collect the measured weights of the reservoirs and to control the pumps (setting of their speed, start and stop), but also to acquire the readings of the instrument under test. Instruments having a serial output are directly connected to the PC whereas the other instruments are connected to a data-acquisition and interface unit that is connected to the PC. Instruments with an analog signal like a voltage, current or a pulse output are

connected to the corresponding input of the data-acquisition unit, but the signal of a raw reed contact first goes through a so-called monostep in order to convert it to a well behaved pulse. Figure 1 shows a sketch of the test setup and a picture of the setup with the KNMI precipitation gauge.

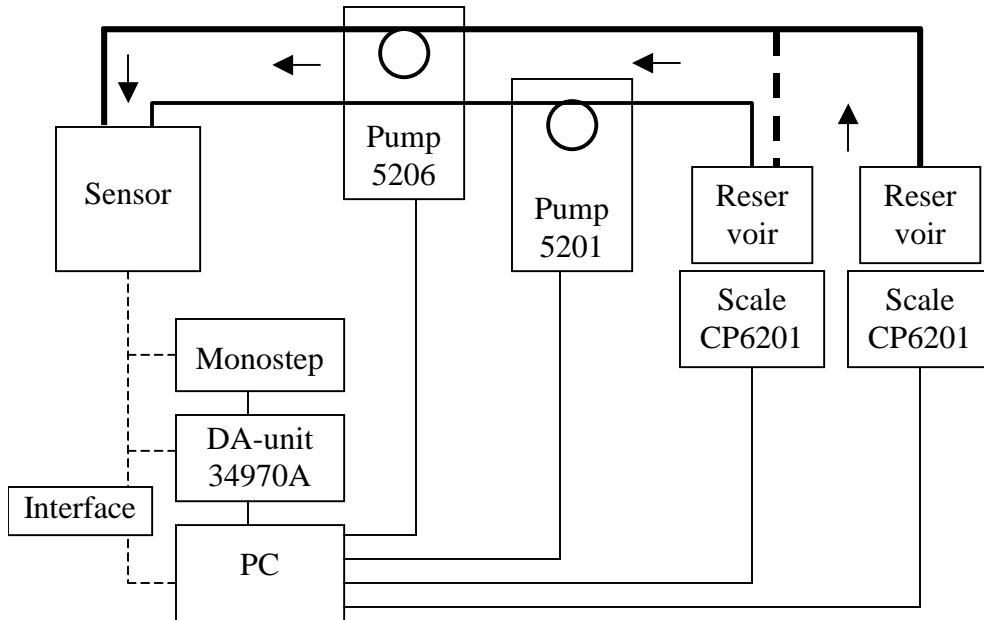

Figure 1: Sketch of the KNMI test setup used for the WMO laboratory intercomparison of rainfall intensity gauges and a photograph of the setup with the KNMI precipitation gauge.

The pumps consists of a Heidolph peristaltic pump drive PD 5201 with a serial RS232 interface and a pump head SP mini for the low flow rates and a Heidolph pump drive PD 5206 with a serial RS232 interface and a pump head SP quick for the middle and high flow rates. The speed range of the pump drives is 5-120 and 24-600 revolutions/min for the PD 5201 and PD 5206 pump drives respectively. The pumps are operated using silicon tubes with an internal diameter of 0.8, 3.1 and 6.3 mm each. With these combinations the range of the flow rates is 0.2-4.8 ml/min for the PD 5201 with the 0.8mm tube and 1.6-40, 25.7-643 and 88.7-2217ml/min for the PD 5206 with tubes of internal diameters of 0.8, 3.1 and 6.3 mm, respectively. Before the test setup was used for the WMO intercomparison the pump drives/tubes were calibrated. During the tests no recalibration was required since the obtained flow rates were always such that the reference intensity remained within the required range. The required reference intensities for each instrument are related to a flow rate and the collector area according to the relation:

$$\text{intensity (mm/h)} = 600 \times \text{flow rate (ml/min)} / \text{area (cm}^2\text{)}.$$

For each reference intensity the tube with the lowest diameter is selected that can provide the required intensity. Care is taken that the flow rate is not near the boundaries of the speed range of the pump. Via the serial port the PC can select the tube diameter and the speed of the pump as well as start and stop the pump. A dedicated application that runs on the PC uses a control file in which the required tube/speed settings and the duration of the run are listed and where stops are pre-programmed in case the tube on the PD 5206 pump needs to be changed or the water in the reservoir needs to be refilled. In these cases an acknowledgement of an operator is always required, but during normal operation the intensity levels change automatically without human intervention.

Two electronic precision scales of Sartorius model CP6201 are part of the test setup. The scales have a range of 6200g and a resolution and a repeatability of 0.1g. The linearity of the scales is within  $\pm 0.2\text{g}$  and the sensitivity drift is  $\leq \pm 5 \cdot 10^{-6}\text{g/K}$ . The response time of the scales is less than about 1 second. The scales have a serial interface through which the weight can be acquired by the PC. The scales are aligned using the spirit level that is built into the instrument.

An Agilent 34970A data acquisition unit is connected to the IEEE port of the PC. This unit can be equipped with up to 3 plug-in modules. For this test the multifunction module HP-34907A was used since it contains a totalizer input that was used to count the pulses. 2 of these modules have used for sensors that reported a raw as well as a corrected pulse output. During the test the acquisition PC scans the appropriate ports and reads the total amount of pulses received.

The raw signal of the reed contact goes through a so-called monostep (mono-stabile multi-vibrator) in order to convert the raw reed signal into a well-behaved pulse that can be correctly measured by the totalizer. A scheme of the monostep is given below (cf. Figure 2). The monostep has 2 limits that, depending on the reed contact properties, can be changed. The resistance  $R$  and capacity  $C$  should be within the limits for the pulse length (PL) and the pulse repetition time (PRT) according to the relation

$PL < R \times C < PRT$ . For each reed contact a suitable choice was made such that (i) the individual tips are counted correctly (i.e. the raw reed contact signal is converted into a single pulse) and (ii) the tips coming rapidly after one another at high intensity levels can still be distinguished as individual pulses, i.e. for a  $PL = 5$  ms and a  $PRT = 0.5$  s the values  $R = 10k\Omega$  and  $C = 0.1\mu F$  where adopted. Note that an RC-filter was used to obtain well-behaved pulses for the tipping buckets in the first batch of instruments tested at KNMI.

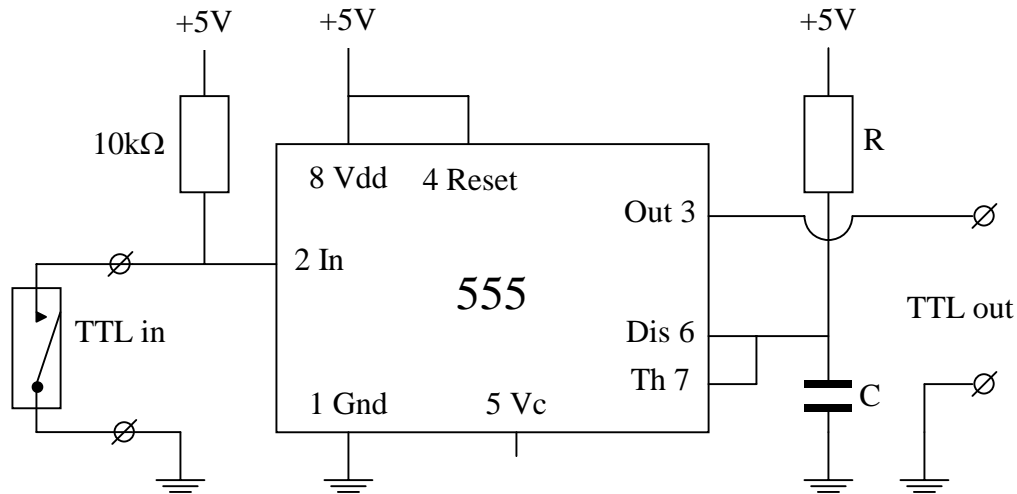

Figure 2: Scheme of the monostep used in the WMO laboratory intercomparison of rainfall intensity gauges at KNMI.

The acquisition PC is a standard desktop PC running Windows 95 and TestPoint software to perform the laboratory tests. The PC was equipped with an IEEE board and a Digi serial communication board (PC/8e, AccelePort 8e) to increase the number of serial ports with 8 in order to handle all the peripherals.

The TestPoint application controls the tests. A screen dump of this application is shown in Figure 3. At start-up the application initializes the connections and requests the serial number of the rain gauge and the environmental parameters. Next the application goes through a cycle of measurements as specified in a control file. An example of such a control file is given in Table 4. The first line contains some general information on the precipitation gauge. Each next lines specify the pump, tube, flow rate and duration of each test for a specific intensity. The application automatically performs the individual intensity tests, i.e. one intensity after another. If desired a flow rate of 0 can be used to introduce a waiting period during which no precipitation is given to the instrument. The application waits for an acknowledgement of the operator when the tube changes, because after a change manual activation of the pump must be carried out in order to fill the tube. Such stops can also be used to refill the reservoir. Once a new intensity level has been set the application restarts the pump with the desired flow rate and after a short delay performs a measurement of the scales and instrument c.q. data acquisition unit every 5 seconds. The scales, data acquisition unit and instruments are generally polled, but some sensors cannot be polled but give a data telegram automatically. In that case the application checks regularly for the receipt of a new data telegram and at the 5-second

interval the last received telegram is stored. During the test of the first batch of instruments at KNMI a sampling rate of 10 seconds was used, but for better sampling an interval of 5 seconds was chosen afterwards. When a intensity test has been completed for a specified duration the pump is stopped by the PC application. This TestPoint application reads the next line of the control file and starts either the next intensity run or, in case of end-of-file, asks the user for the environmental parameters and stops the test.

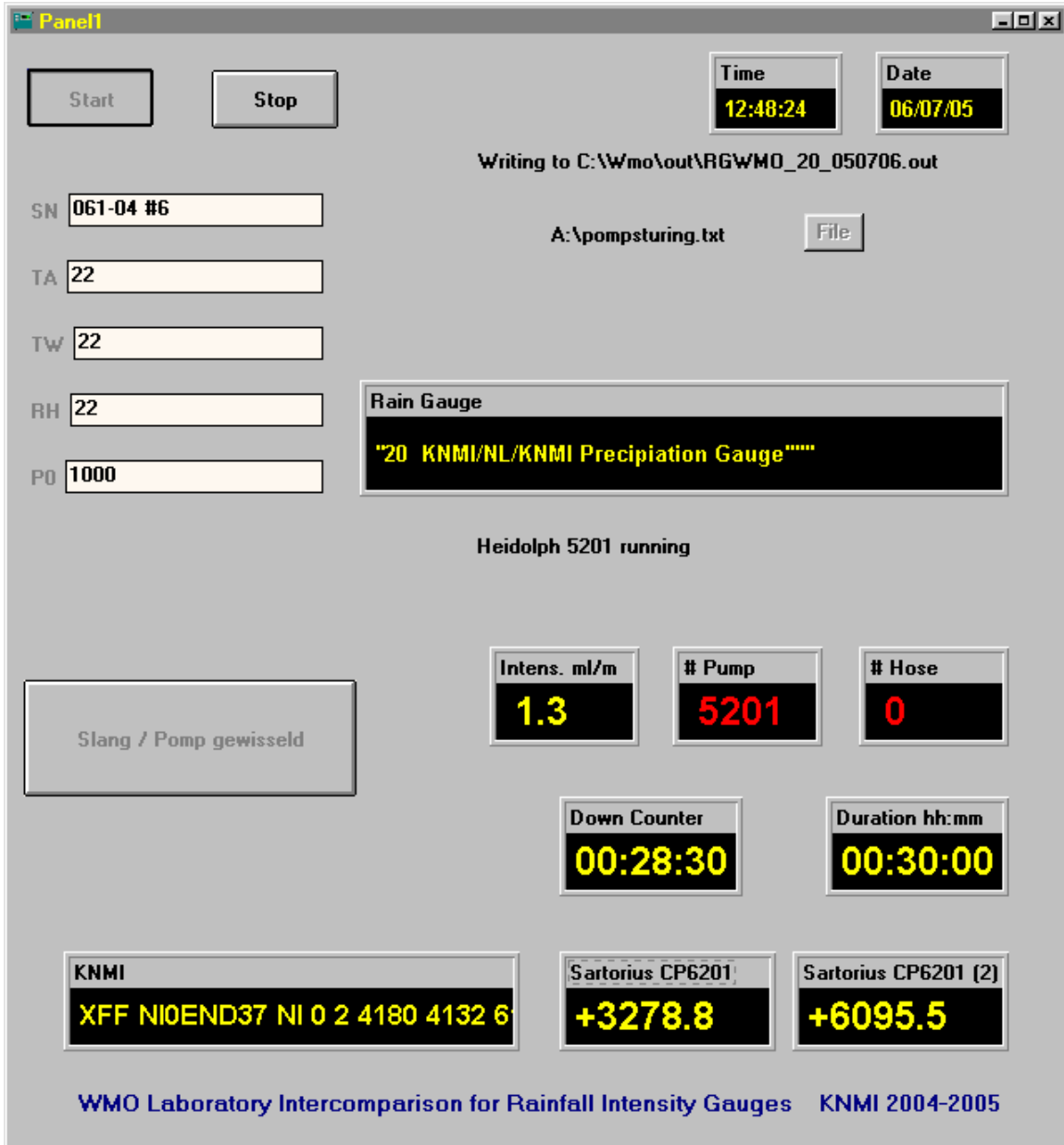

Figure 3: Screenshot of the TestPoint application used during the WMO laboratory intercomparison of rainfall intensity gauges at KNMI.

The environmental parameters, the parameters for each intensity run and the 5-second readings of the scales and instrument are stored in a file during the test. The raw data

telegram of the instrument is generally stored. Analysis of the results is performed off-line in predefined standard Excel spreadsheets as agreed within the IOC/ET.

Table 3: Example control file of the KNMI TestPoint application used for testing the Ott Pluvio precipitation gauge. After the header the parameters for each intensity run are given. Manual actions, e.g. changing the tube or refilling the reservoir, and acknowledgment is required when the tube size increases, which is indicated in this table by the vertical lines. Note the waits (intensity=0) that are introduced before and after each intensity run or manual action in order to isolate the delay of the sensor.

"9 OTT Hydrometry/Germany/Pluvio 250 mm (Weighing)""				
Pump	Head	Tube	Int.	Duration (min)
5201	0	0	0	8
5201	0	0	0.7	25
5201	0	0	0	8
5206	0	0	6.7	15
5206	0	0	0	5
5206	0	0	16.7	15
5206	0	0	0	5
5206	0	5	0	5
5206	0	5	30.0	15
5206	0	5	0	5
5206	0	5	43.3	15
5206	0	5	0	5
5206	0	5	56.7	15
5206	0	5	0	5
5206	0	5	66.7	15
5206	0	5	0	5
5206	0	0	0	1
5206	0	5	0	5
5206	0	5	121.1	15
5206	0	5	0	5
5206	0	10	0	5
5206	0	10	220.1	15
5206	0	10	0	5
5206	0	5	0	1
5206	0	10	0	5
5206	0	10	400.0	12
5206	0	10	0	5
end				

## 2.5. Measurement uncertainty of the KNMI test setup

The reference intensity is defined in relation to the decrease in mass ( $\Delta\text{mass}$ ) of the water in the scale(s) over a time interval ( $\Delta\text{time}$ ) according to:

$$\text{Intensity (mm/h)} = 36000 \times \Delta\text{mass (g)} / \rho (\text{g/cm}^3) / \text{area (cm}^2) / \Delta\text{time (sec)}$$

As mentioned in the previous section, the absolute measurement uncertainty of each scale is 0.2 g. Note that for mass the uncertainty of the measurement of the total mass is not of importance, but only the change in mass over a certain time period, hence an uncertainty for  $\Delta\text{mass}$  of  $dm = 0.14$  g is adopted (uncertainty is expressed by the symbol 'd'). The density of water is defined as  $\rho = 1 \text{ cm}^3/\text{g}$  and varies slightly with temperature, pressure,

and composition. The density of pure water is 0.999 g/ml at 15.6°C, 0.998 g/ml at 21°C, 0.997 g/ml at 25.2°C and 0.996 g/ml at 28.8°C. The density of tap water is only slightly higher than for pure water, but seawater is about 2.5 % heavier than pure water. In this report a density of tap water 1 g/ml is adopted with a relative uncertainty of  $d\rho/\rho = 0.5\%$ . The area of the orifice of the sensor is specified by manufacturer and adopted without modification. Note that environmental impacts like wind usually affect the measurement in the field. Estimated corrections are sometimes incorporated in the value of the orifice area by defining an "effective orifice area", provided by the manufacturer. For this laboratory intercomparison only the real orifice area is used. The uncertainty of the time interval as measured by the acquisition PC is better than 1 s over the time intervals in question. Some sensors update at a regular time interval and some sensors report the increment of a precipitation level directly. The data-acquisition PC reads and stores the sensor and scales every 5 s. Note that for the first batch of gauges calibrated at KNMI a sample interval of 10 s was used. Hence an uncertainty of the absolute time stamps  $t$  of  $dt=7$  s (14 s for first batch) is used in case the sensor reports a measurement asynchronously. The time accuracy for tipping bucket sensors is furthermore scaled with the number of tips per sample interval according to  $dt = 7 \text{ s}/\#\text{tip}$  where the number of tips is 1 or higher. An uncertainty of  $dt = 1.4$  s is adopted in case the sensor can be polled and replies with an instantaneous value. The measurement of mass  $m$  is in addition affected by evaporation  $E$ . The second identical scale is used to measure the intensity of evaporation,  $I_E$ , and the reference intensity  $I_r$  is corrected for evaporation. At high intensities, when both scales are used to provide the larger amounts of water, or during the first batch when the second scale was sometimes not used to determine the evaporation, an estimated value of the evaporation is used (see Table 4). The uncertainty of the evaporation correction is assumed to be given by  $dI_E = 0.02$  mm/h. The overall accuracy is determined by the errors caused by evaporation, the uncertainty in the density of tap water and in the measurement of mass and time. The contribution of each of these error sources is assumed to be independent. Hence, from the relation

$$I_r - I_E = \text{constant} \times \Delta m / \Delta t \times 1 / \rho$$

it can be shown that the relative uncertainty of the test setup is given by:

$$dI_r/I_r = |dI_E/I_r| + \sqrt{[(dm/\Delta m)^2 + (dt/\Delta t)^2 + (d\rho/\rho)^2]}.$$

The accuracy depends on the duration and the total amount of mass used for the test, which vary. The amount of water used in the test setup generally increases with precipitation intensity and hence the accuracy of the results increases for higher intensities. Furthermore gauges with a larger surface area require, for a given intensity, more water than sensors with a smaller surface area resulting in a higher accuracy for sensors with a larger surface area. In order to compensate for these effects the test runs at low intensities and for sensors with a smaller surface area have a longer duration. The duration of the runs was determined such that for a tipping bucket gauge at least 10 tips occur with a minimum of 16 minutes, and for the other sensors such that at least 10 ml = 10 g is pumped into the sensor with a minimum of 5 minutes. When applicable the delay of the sensor was taken into account. The relation between the time interval between 2 tips of a tipping bucket sensor and the intensity is given by:

$$\Delta t_{\text{tip}} (\text{sec}) = \text{tipping bucket content (ml)} / \text{flow rate (ml/min)} \times 60,$$

and since tipping bucket content (ml) = tipping bucket resolution (mm)  $\times$  collector area (cm<sup>2</sup>) / 10 this leads to:

$$\Delta t_{\text{tip}} \text{ (sec)} = \text{tipping bucket resolution (mm)} / \text{intensity (mm/h)} \times 3600.$$

Note that the above expression also determines the minimum time interval that is required in order to be able to calculate the precipitation intensity for a tipping bucket gauge since the occurrence of at least 2 tips is required for that purpose. The uncertainties obtained with the above expression are given in Table 4. For that purpose the decrease in mass and the time interval between the start and end of each intensity run are considered. For tipping bucket sensors the interval is restricted to the interval between the first and last tip reported in an intensity run.

Table 4: Overview of the uncertainties for the test runs with the different precipitation gauges and intensity levels. The last column reports the typical evaporation rate that was measured during the test runs (\*' indicates an estimated evaporation rate).

No.	Gauge	Relative uncertainty of $I_r$ (%)					$I_E$ (mm/h)
		2 mm/h	20 mm/h	50 mm/h	200 mm/h	maximum	
1	Rimco 7499	1.7	1.6	1.3	0.7	0.6	0.07
2	TB-3	1.7	1.6	1.4	0.8	0.5	0.06
3	AP23	1.7	1.0	0.9	0.6	0.5	0.07
4	Alluvion 100	1.8	1.8	1.6	0.9	0.7	0.15*
5	MRW500	1.5	0.6	0.8	0.8	0.8	0.09
6	MR3H-FC	2.0	1.7	1.2	0.6	0.5	0.05
7	VRG101	4.3	3.1	3.0	3.0	3.0	0.05
8	Nilometre	2.0	1.5	1.5	1.4	1.4	0.07
9	Pluvio 250	2.2	1.9	1.8	1.8	3.0	0.25
10	TBRG Mk2	1.4	1.1	1.0	0.9	0.6	0.09
11	UM7525	1.6	1.0	0.9	0.8	0.6	0.03
12	PMB2	1.6	1.0	0.9	0.8	0.6	0.03
13	R102	1.7	1.1	0.9	0.9	0.9	0.02
14	WMB01	1.5	1.2	1.9	1.6	1.6	0.10*
15	T-200B	2.4	1.1	0.9	0.9	0.8	0.16*
16	TRwS	1.7	0.9	0.8	0.8	0.8	0.05
17	1518H3	1.7	1.0	0.9	0.6	0.5	0.16
18	100000E	1.5	1.0	0.9	0.8	0.6	0.08
19	H-340SDI	1.5	1.0	1.0	0.8	0.6	0.10
20	KNMI	2.2	3.1	3.0	3.0	3.0	0.08

The above table gives the measurement uncertainty as a function of the reference intensity. It should be noted that the reported uncertainties are upper limits. On the sensor side various error sources can be of importance. Apart from sensor specific errors related to mechanic or electronic design, errors occur as a result of evaporation, wetting and out-splashing. The evaporation rates reported in Table 4 are expressed in terms of an intensity

rate with respect to the rain gauge under consideration, although the evaporation loss of the reference stems from the reservoir with a surface area of 530 cm<sup>2</sup>.

## 2.6. Data analysis

For each instrument 5 test runs are performed at the predefined 7 to 10 intensities levels depending on the intensity range of the instrument under consideration. The intensity results are determined for each run individually. Generally the results of the first 20 seconds of a run are not considered in order to eliminate startup effects of the pumps. When considering tipping buckets sensors only the interval between the first and last tip that occurred in an intensity run is considered. For the other types of precipitation sensors the reporting delay, if applicable, has to be taken into account. The total amount of precipitation in the remaining time interval can be converted into precipitation intensity and compared to the reference. Apart from this analysis in terms of precipitation totals at fixed reference intensity, an analysis of the running one-minute averaged precipitation intensity is also considered. In that case the running one-minute averaged precipitation intensity is averaged over the test interval and the standard deviation of the running one-minute averaged precipitation intensity is also determined. Note that for a tipping bucket sensor a one-minute running average cannot be determined when the precipitation intensity is low because at least one tip per minute is required to compute a one-minute averaged precipitation intensity. For tipping bucket sensors the variability of the time interval between individual tips is studied, but the data-acquisition period of 5 seconds puts constraints on these results.

Another analysis considers precipitation sums only and compares the total amount of precipitation reported by an instrument with the reference over the entire time interval that takes the delay of the sensor after cessation of the intensity run into account.

The results are presented for each sensor in the following form:

- The relative error  $e = (I - I_r) / I_r \times 100\%$ , where  $I$  is the intensity measured by the instrument and  $I_r$  the reference intensity, is evaluated at each reference flow rate for each run individually;
- Five tests are performed per each set of reference intensities, so that five error curves are associated with each instrument;
- An averaged error curve is obtained by discarding the lowest and highest error value obtained per each reference flow rate and evaluating the arithmetic mean of the three remaining error and reference values;
- A second order polynomial of the form  $e(I_r) = a \times I_r^2 + b \times I_r + c$  with  $a$ ,  $b$  and  $c$  suitable numeric coefficients is fitted to the averaged error curve over the whole range of operation of the instrument;
- A power log of the form  $I = a \times (I_r)^b$  is fitted to the averaged intensity  $I$  measured by the instrument and the averaged reference intensity  $I_r$  corresponding to three remaining points after discarding for each reference intensity the points with the lowest and highest error.
- Furthermore, the second order polynomial fit and the power log are computed for each type of sensor by considering averaging the three points of both instruments.

Apart from the above analysis that was agreed upon within the WMO laboratory intercomparison some further analysis was performed in order to express the results in terms of an overall error. For that purpose:

- The standard error  $E = \sqrt{\left(\sum_{I_r} [(I - I_r)/I_r]^2\right) / \left(\sum_{I_r} 1\right)} \times 100\%$  is calculated between the averaged 3-point measured intensity  $I$  and the reference intensity  $I_r$ .

In order to illustrate the effect of a correction by using the polynomial fit and the power law fit the corresponding standard errors are also calculated by:

- The standard error  $E_c = \sqrt{\left(\sum_{I_r} [(I - I_r \times [1 + e(I_r)]) / (I_r \times [1 + e(I_r)])]^2\right) / \left(\sum_{I_r} 1\right)} \times 100\%$  between the averaged 3-point measured intensity  $I$  and the reference intensity  $I_r$  but corrected according to the above derived second order polynomial  $e(I_r)$ .

- The standard error  $E_p = \sqrt{\left(\sum_{I_r} [(I - a \times (I_r)^b) / (a \times (I_r)^b)]^2\right) / \left(\sum_{I_r} 1\right)} \times 100\%$  between the averaged 3-point measured intensity and the power law fit  $a \times (I_r)^b$  of the reference intensity.

In addition these standard errors are calculated for the combination of the results of both instruments.

Furthermore are reported:

- The intensity range is reported were the averaged sensor results are within the  $\pm 5\%$  range of the reference intensity as required by WMO.
- The relative error  $\Delta I_{12} / I_{12} \times 100\%$  between the averaged 3-point measured intensity of sensor 1 and 2, where  $I_{12}$  is the averaged measured intensity for sensors 1 and 2 for each reference intensity and  $\Delta I_{12}$  is their difference at  $I_{12}$  by using linear interpolation of the errors.

### 3. Results and discussions

In this section the results of the intensity runs of each instrument are presented and discussed. Details of the data analysis are given and the results are shown. General comments on the instrument and the test results are also included. The results and curves in the format as discussed in section 2.6 are given for each sensor in the corresponding Appendix.

#### 3.1. *Mc Van Instruments Rimco 7499*

The Rimco 7499 is a tipping bucket rain gauge with a resolution of 0.2 mm and the collector diameter is  $203\pm 0.2$  mm. The instrument has a reed switch output and applies no correction. However, the sensor uses a siphon mechanism to control the flow of water from the collecting funnel to the tipping balance. Generally tipping bucket sensors suffer from the well-known deficiency that incident water is lost during the time it takes to perform a tip of the balance. The resulting underestimation of the amount of precipitation depends on the precipitation intensity and increases with rainfall rate. Normally a tipping bucket rain gauge is calibrated and adjusted at a fixed rainfall rate that is most typical for the area of application. Hence the above-mentioned effect leads to an overestimation for intensities lower than the intensity at which the instrument is calibrated and an underestimation for higher intensities. The idea behind the siphoning mechanism is that a flow is generated which is more or less independent of the actual precipitation intensity to anticipate the above mentioned error. The capacity of the siphoning mechanism is not specified in the specification sheet, but it is about between 1 and 2 times the capacity of the tipping bucket so that either 1 or 2 tips are reported as a result of a siphoning event. The manufacturer states an accuracy of  $\pm 1$  % for rainfall rates up to 250 mm/h and  $\pm 3$  % up to 500 mm/h.

The test results of this sensor are shown in Appendix 1 and are summarized in Figure 4. The results have been obtained by considering the decrease in mass of the reservoir used for the reference intensity and the number of tips reported by the sensor over a period between the first and last tip reported by the sensor. The first 15 s of each intensity run are ignored in order to eliminate startup effects. The results for both instruments are quite consistent and are within 1-2 % of each other except at 20 mm/h. The errors of this tipping bucket sensor still show a dependency on precipitation intensity although it uses a siphoning mechanism. The errors exceed +5 % around 200 mm/h. At higher intensities more water is siphoned due to the continuous flow of water and 2 tips occur more often, causing a larger loss of water during the tip and hence the reported underestimation of precipitation intensity. The differences can be nicely fitted by a second order polynomial and after such a correction the results fall within the limits set by WMO. A correction of the form of a power law fit gives for this sensor unsatisfactory results at high precipitation intensities.

Rimco 7499

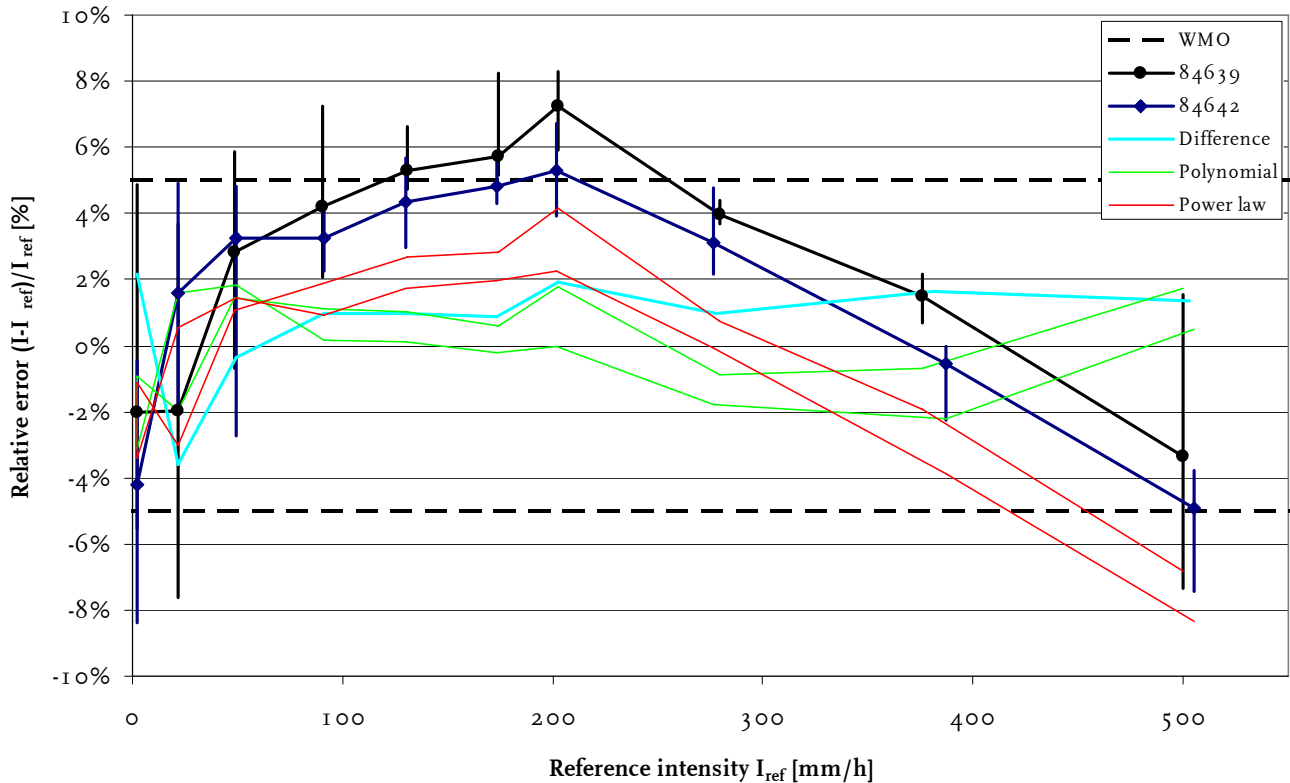

Figure 4: Summary of the test results of the Rimco 7499 instruments showing the averaged test results of both instruments versus the reference intensity, the relative difference between the results obtained for both instruments, and the errors after a correction using the second order polynomial or power law fit has been applied to the data.

The effect of the siphoning system is discussed in more detail. A siphon event causes either 1 or 2 tips of the balance. This effect can be observed in Figure 5, which shows the distribution of the time intervals between 2 consecutive tips of the sensor for all 5 test runs at the reference intensity of 2 mm/h for both Rimco 7499 instruments. The figure shows that the tip intervals for sensor 1 are between 410 and 575 s. When siphoning causes 2 tips, the second tip is either observed in the same 10-second sample interval in which case the time between 2 consecutive tips is halved resulting in the consecutive tips between 190 and 300 s, or the second tip is observed in the next 10-second sample interval, which leads to a consecutive tip after 10 s. Sensor 2 shows the same characteristics, but the time between consecutive tips is generally less than for sensor 1 and the second tip occurs less often in the next 10-second sample interval. If an instantaneous precipitation intensity is calculated between 2 consecutive tips, the intensity after siphoning which causes 1 tip will give an underestimation of the actual intensity because some amount of water is left in the balance, whereas a double tip gives

an overestimation. The averaged time between consecutive tips is 375 and 365 s for sensors 1 and 2 respectively, which corresponds to intensities of 1.92 and 1.97 mm/h. The standard deviation of the time between consecutive tips is 170 (45) and 100 s (27 %) and is very large as a result of siphoning events causing single or double tips. Note that the siphoning mechanism gives the sensor a lower effective resolution and makes it more sensitivity to evaporation losses since water is retained at 2 places. However, the siphoning mechanism reduces the characteristic underestimation of tipping bucket rain gauges.

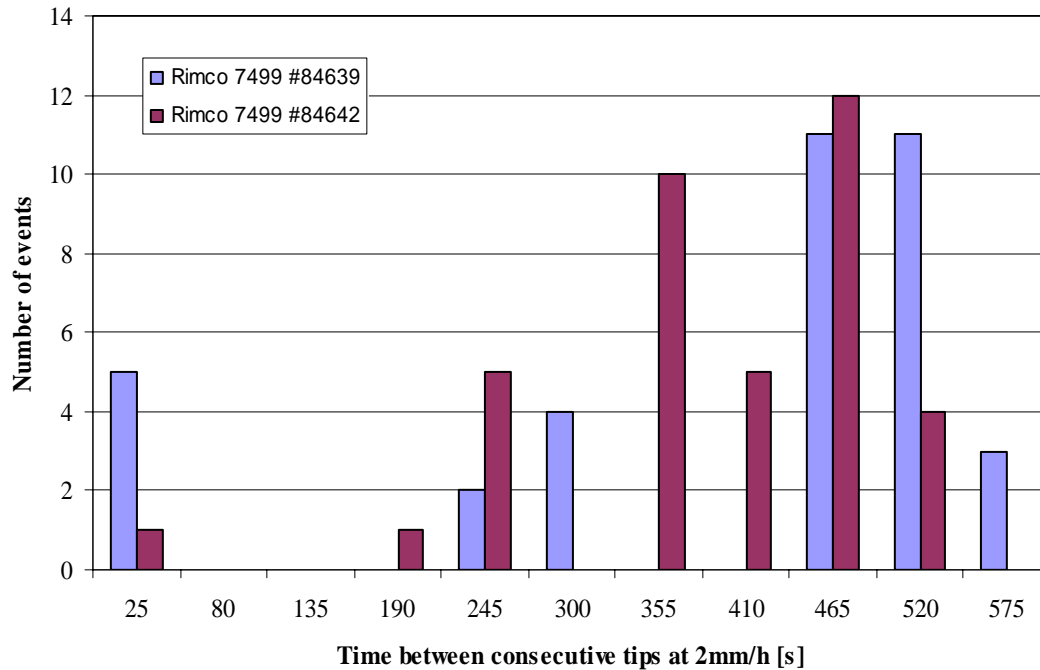

Figure 5: Histogram of the observed time intervals between consecutive tips for both Rimco 7499 instruments at 2 mm/h. The time denoted at the x-axis is the end time of the time interval, hence 5 and 1 tips occur between 0 and 25 s.

Comments related to the Rimco 7499 sensor are:

- The tests for this instrument were performed with a sample interval of 10 s.
- The evaporation of reservoir on the unused second scale was measured in some cases and ranged between 0.05 and 0.09 mm/h. An evaporation of 0.07 mm/h was adopted for all intensity test runs.
- When a sensor had not been used for some days the tipping buckets could get stuck. It could be released again by either “knocking” on the sensor or by flushing it with some larger amount of water (0.5 l).
- The tips occur irregularly at lower intensities. This can only partly be ascribed to the siphoning mechanism that generated either 1 or 2 tips and hence also affects an instantaneous derivation of the precipitation intensity.

- At reference intensities above 368 mm/h some accumulation of water in the collecting funnel was observed which was the equivalent of about 3 tips at 368 mm/h and about 25 tips at 500 mm/h.

### 3.2. Hydrological Services TB-3

The TB-3 is a tipping bucket rain gauge with a resolution of 0.2 mm and the collector diameter is  $200 \pm 0.3$  mm. The instrument has a reed switch output and applies no correction. However, the sensor uses a siphon mechanism to control the flow of water from the collecting funnel to the tipping balance. The capacity of the siphoning mechanism is 0.4 mm so that generally 2 tips are reported as a result of a siphoning event. The manufacturer states an accuracy of  $\pm 2\%$  for rainfall rates between 25 and 500 mm/h. The measuring range is 0 to 700 mm/h.

TB-3

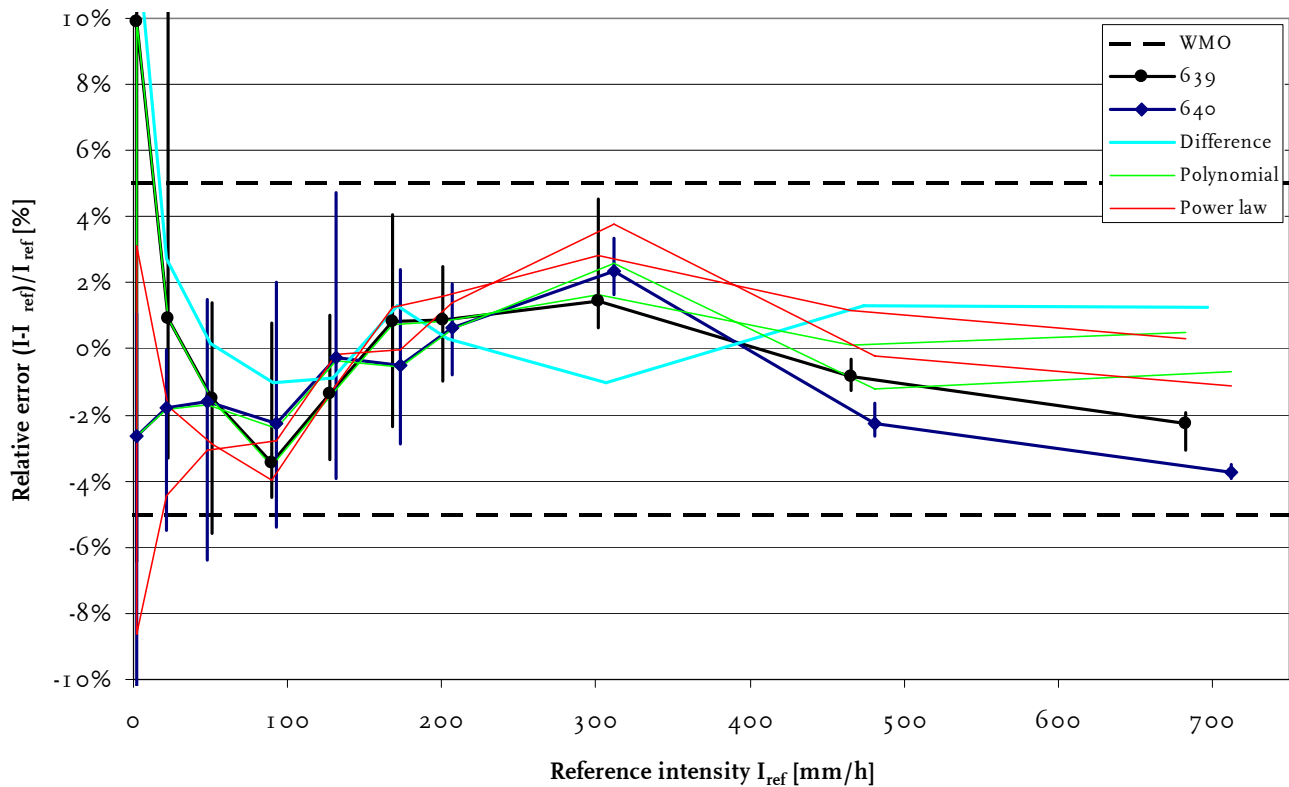
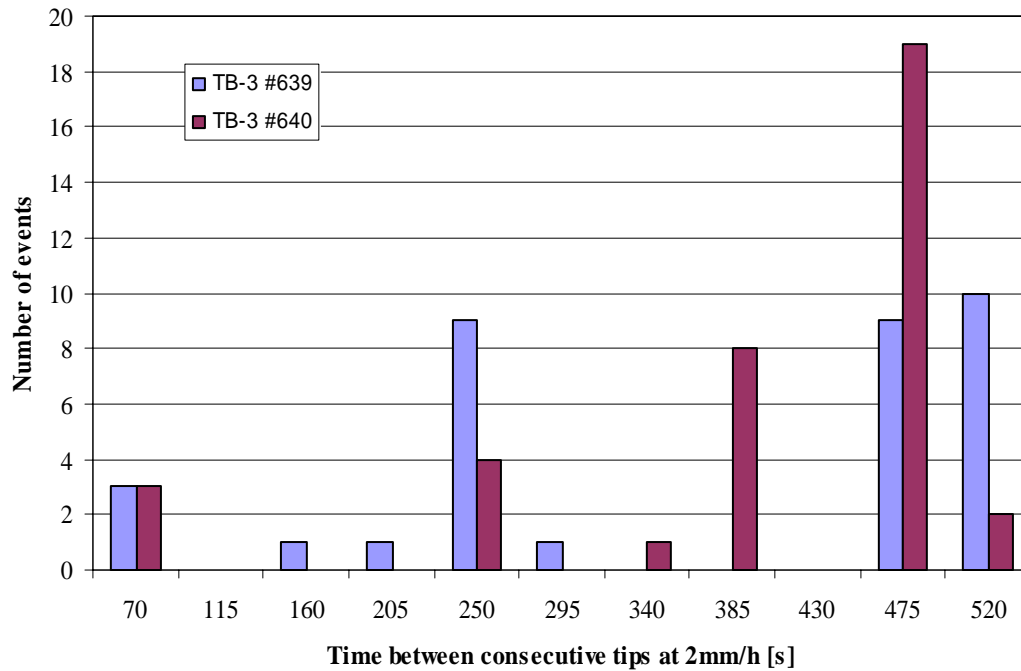

Figure 6: Summary of the test results of the TB-3 instruments showing the averaged test results of both instruments versus the reference intensity, the relative difference between the results obtained for both instruments, and the errors after a correction using the second order polynomial or power law fit has been applied to the data.

The test results of the TB-3 sensor are shown in Appendix 2 and are summarized in Figure 6. The results for both sensors are quite consistent and lie within 1-2 % of each other except at low intensities. The errors of this tipping bucket sensor show less

dependency on precipitation intensity than the Rimco 7499 using a similar siphoning mechanism, but with a smaller capacity. At higher intensities precipitation intensity is again slightly underestimated. The differences can be fitted by a second order polynomial but here such a correction gives only slightly better results than the uncorrected curves at high intensity levels. A correction of the form of a power law fit gives similar results, but

**TB-3**



at low precipitation intensities the correction has a larger effect leading to an averaged underestimation, whereas the polynomial has almost no effect in that region and is dominated by the large overestimation of one of the instruments at 2 mm/h.

Figure 7: Histogram of the observed time intervals between consecutive tips for both TB-3 instruments at 2 mm/h. The time denoted at the x-axis is the end time of the time interval; hence the 3 tips occurring for both instruments after 10 s are reported at 70 s.

Figure 7 shows the distribution of the time intervals between 2 consecutive tips of the sensor for all 5 test runs at the reference intensity of 2 mm/h for both TB-3 instruments. The figure shows that the tip intervals for sensor 1 are between 430 and 520 s. Two consecutive tips appear between 115 and 295 s, or at 10 s. Sensor 2 shows the same characteristics, but the time between consecutive tips is generally larger than for sensor 1. Sensor 2 reported 9 tips between 295 and 385 s and no tips between 115 and 205 s whereas sensor 1 reported 0 and 2 tips in these ranges respectively. The averaged time between consecutive tips is 348 and 373 s for sensors 1 and 2 respectively, which corresponds to intensities of 2.07 and 1.93 mm/h. The standard deviation of the time between consecutive tips is 160 (46) and 135 s (36 %) and is again very large as a result of siphoning events causing double tips.

Comments related to the TB-3 sensor are:

- The tests for this instrument were performed with a sample interval of 10 s.
- The evaporation of reservoir on the unused second scale was measured in some cases and ranged between 0.04 and 0.08 mm/h for sensor 1 and between 0.04 and 1.0 mm/h for sensor 2. An evaporation of 0.06 and 0.07 mm/h was adopted for all intensity test runs of sensor 1 and 2 respectively.
- The tips occur irregularly at lower intensities.

### 3.3. Anton Paar AP23

The AP23 is a tipping bucket rain gauge with a resolution of 0.1 mm and the collector area is 500 cm<sup>2</sup>. The instrument has a reed switch output and applies no correction. The manufacturer calibrates the instrument at a precipitation rate of 1 mm/min (=60 mm/h). The reported reproducibility of the calibration is ±0.5 %. The manual gives a graph of the deviation of the sensor as a function of the precipitation intensity, which is about 103 % at 6 mm/h and decreases smoothly to about 73 % at 600 mm/h. The manufacturer states an accuracy of ±1 % for rainfall rates between 6 and 150 mm/h when the correction curve is applied. The measuring range is 0 to 720 mm/h. Note that only 1 AP23 instrument was available for this test.

#### AP23

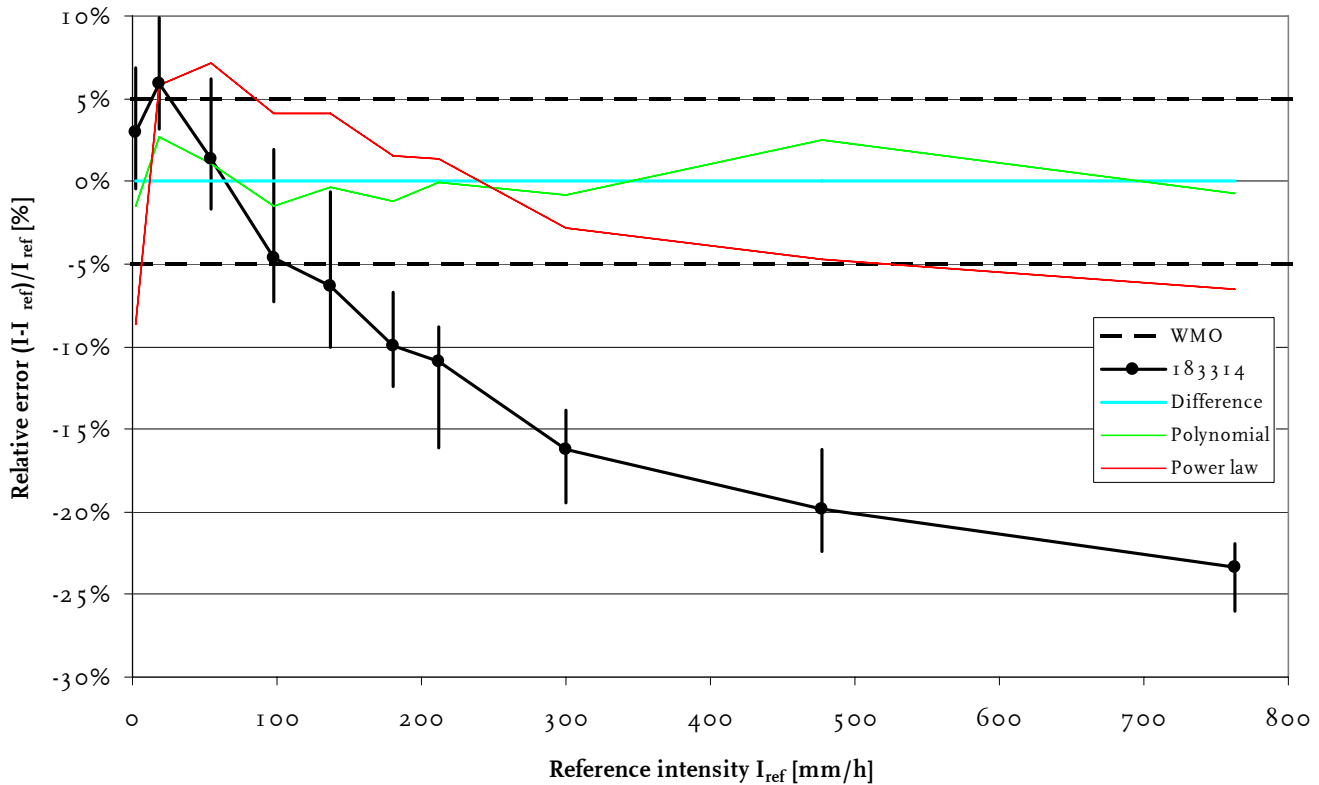

Figure 8: Summary of the test results of the AP23 instrument showing the averaged test results of the instrument versus the reference intensity, and the errors after a correction using the second order polynomial or power law fit has been applied to the data.

The test results of the AP23 sensor are shown in Appendix 3 and are summarized in Figure 8. The results for this uncorrected tipping bucket sensor show the characteristic behavior of the errors as a function of precipitation intensity. The errors cross 0 % near 60 mm/h, i.e. the intensity where the instrument is calibrated. At lower intensities the sensor overestimates the precipitation amount, whereas at high intensities the sensor underestimates the intensity up to 23 % at 760 mm/h. These errors can be fitted nicely by a second order polynomial. Using this polynomial as a correction leads to errors within  $\pm 2$  %. A correction of the form of a power law fit gives not so good results, at low and high precipitation intensities.

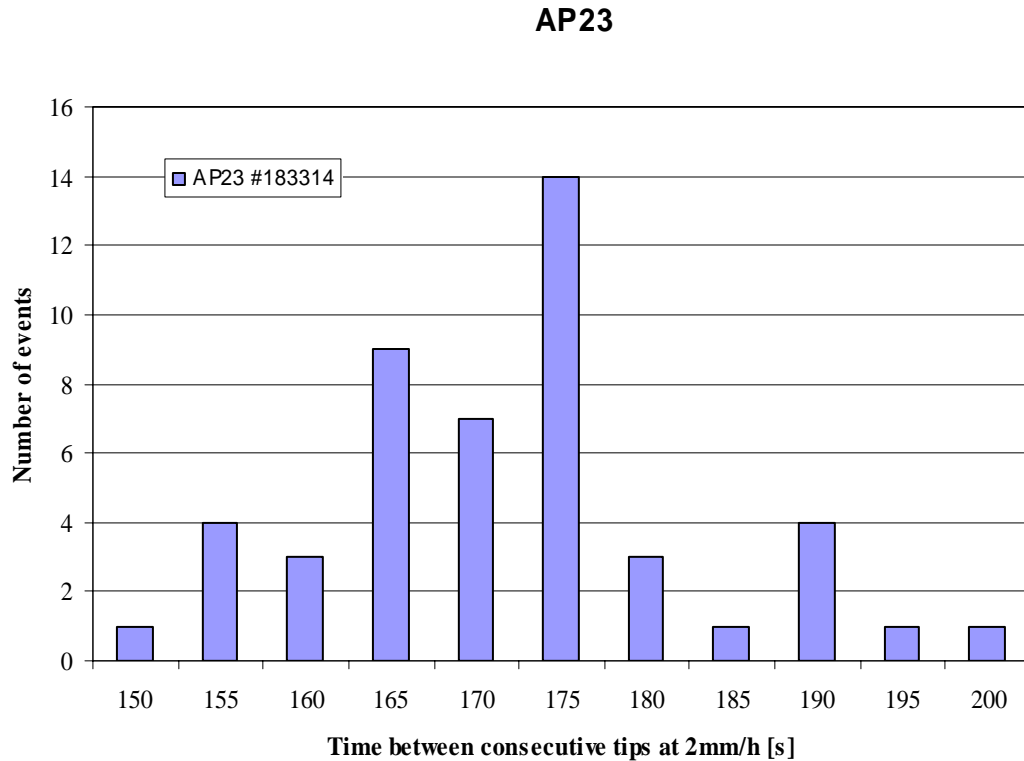

Figure 9: Histogram of the observed time intervals between consecutive tips for the AP23 instrument at 2 mm/h. The time denoted at the x-axis is the end time of the time interval; hence the entry at 150 denotes the tip that occurred 150 s after the previous tip. Note that in this case the tip at 200 occurred after 205 s since all tips outside the range are placed in the limiting bins.

Figure 9 shows the distribution of the time intervals between 2 consecutive tips of the AP23 sensor for all 5 test runs at the reference intensity of 2 mm/h. The figure shows that the tip interval ranges between 150 and 205 s. The averaged time between consecutive tips is 169 s, which corresponds to an intensity of 2.13 mm/h. The standard deviation of the time between consecutive tips is about 10 s and corresponds to an uncertainty of about 6 %.

Comments related to the AP23 sensor are:

- The tests for this instrument were performed with a sample interval of 5 s.
- The evaporation of the reservoir on the unused scale was measured for intensities up to 200 mm/h and ranged between 0.04 and 0.11 mm/h. This measured evaporation value is compensated in the data analysis. An evaporation of 0.07 mm/h was adopted for intensity levels above 200 mm/h.
- Only one sensor was available for this test.
- The sensor has no spirit level for alignment.
- The sensor has no debris protection filter.
- One temperature sensor in the base of the tipping bucket mechanism was loose.
- The German manual did not state the closing time of the reed contact. A value of 0.1 ms was adopted.
- The sensor shows some spatter above 307 mm/h and 470 mm/h, but at 720 mm/h much spatter occurs and not only at the bottom, but also at the top/side of the housing. This is probably due to the bend below the funnel. Possibly this spatter caused the loosening of the temperature sensor since most of the spatter seems to end up in that location.
- At 720 mm/h about 3-4 cm of water accumulates in the lower funnel that cause 8-9 additional tips after the end of the intensity run.
- The tips occur regularly over the whole intensity range.

### **3.4. Axys Environmental Syst. Alluvion 100**

The Alluvion 100 is water level rain gauge with a funnel diameter of 112 mm that guides the water via a debubbler to a measuring chamber. This chamber contains a conductive solid-state level sensor, which gives a signal for every 0.2 mm of precipitation. The measuring chamber is siphoned when 1.2 mm of accumulated. The tested instruments were equipped with electronics and a serial RS-232 port that reports the accumulated precipitation and updates every second. The sensor output also reports the reset counter since the accumulation amount is reset whenever 255 mm is reached. The manufacturer gives an accuracy of  $\pm 2\%$  for rainfall rates between 0 and 150 mm/h and  $\pm 5\%$  for intensities between 150 and 300 mm/h. The measuring range is 0 to 300 mm/h.

Since the Alluvion 100 sensor reports discrete accumulation levels as a tipping bucket rain gauge, the same analysis has been performed. The test results of the Alluvion 100 sensor are shown in Appendix 4 and are summarized in Figure 10. The results for this sensor show large differences between the 2 instruments. The behavior of the error of both sensors is identical, but the results of sensor 1 are about 18 % lower compared to sensor 2. The reason for this discrepancy is unknown. Furthermore, the results for sensor 2 show large deviations for some intensity runs. In these situations the sensor siphoned continuously so that the sensor reports hardly no precipitation. In run 5 the results for 200 and 262 mm/h were manually changed because no precipitation was measured at all. Although it makes no sense in this situation, the second order polynomial and the power law fit and their corresponding corrections are indicated in the results. When the offset of sensor 1 and the continuous siphoning of sensor 2 can be traced and solved, the resulting error curves in combination with an intensity dependent correction will probably place the results of this sensor within the WMO limits.

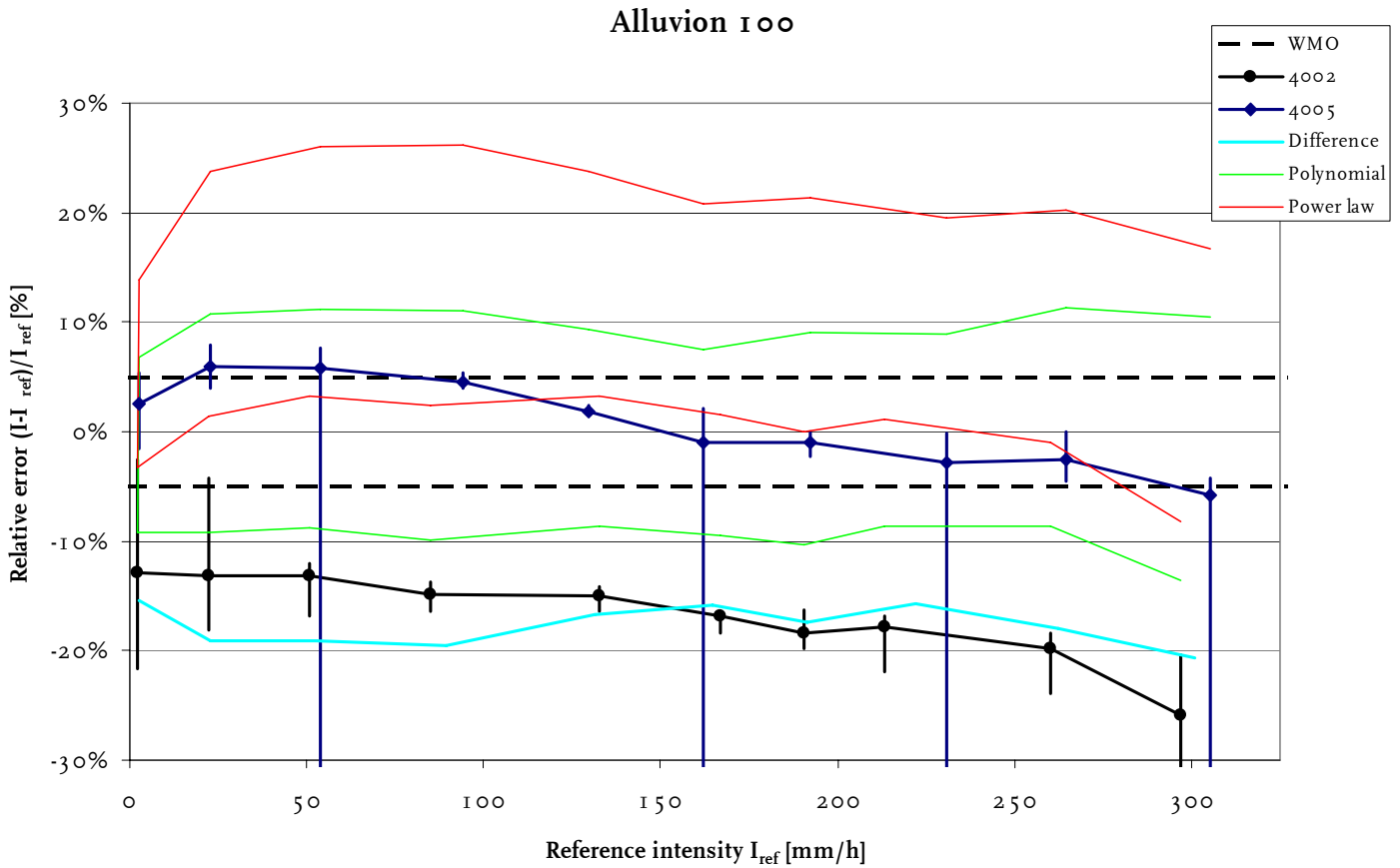

Figure 10: Summary of the test results of the Alluvion 100 instruments showing the averaged test results of both instruments versus the reference intensity, the relative difference between the results obtained for both instruments, and the errors after a correction using the second order polynomial or power law fit has been applied to the data.

Figure 11 shows the distribution of the time intervals between 2 consecutive increments of the sensor for all 5 test runs at the reference intensity of 2 mm/h for both Alluvion 100 instruments. The figure shows that the increments for sensor 1 occur between 100 and 800 s whereas the increment for sensor 2 occur between 100 and 590 s and mainly between 170 and 310 s. The averaged time between consecutive tips is 354 and 292 s for sensors 1 and 2 respectively, which corresponds to intensities of 2.03 and 2.46 mm/h. The standard deviation of the time between consecutive tips is 173 (49) and 128 s (44 %) and is very large for both sensors, particularly if one considers that the standard deviation is not affected by multiple increments. Note that the results at 2 mm/h were not affected by continuous siphoning.

### Alluvion 100

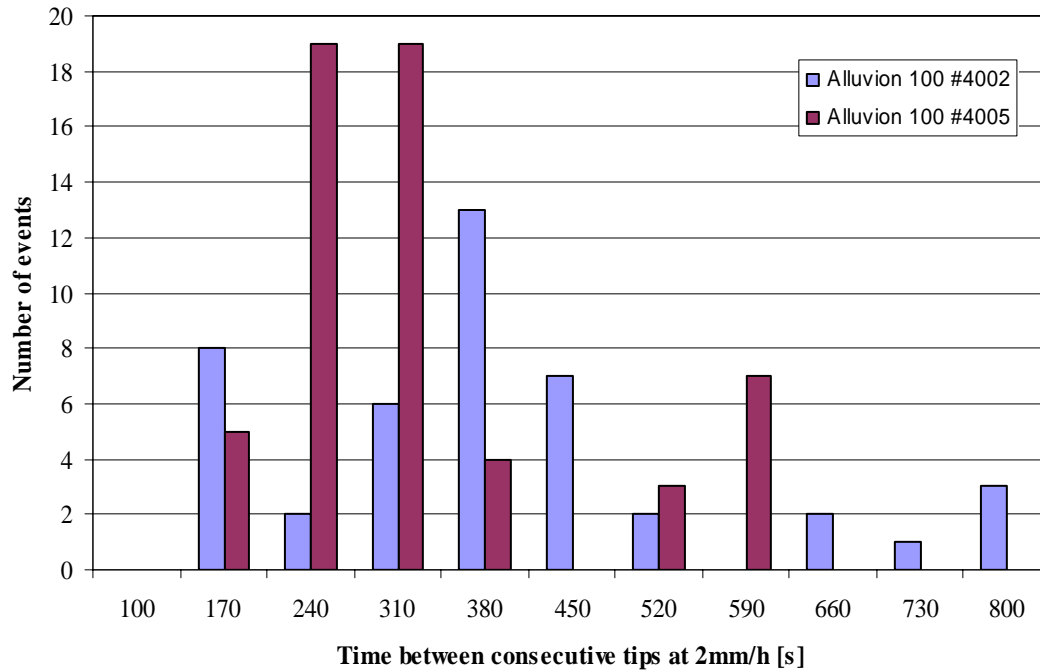

Figure 11: Histogram of the observed time intervals between consecutive increments for both Alluvion 100 instruments at 2 mm/h. The time denoted at the x-axis is the end time of the time interval.

The Alluvion 100 has a serial output that is updated every second, although the accumulated precipitation is only updated when an increment of 0.2 mm is detected. As an example running 1-minute averaged intensities are calculated for this sensor. The observed behavior is typical for other sensors that use discrete increments of precipitation such as tipping bucket rain gauges. The running 1-minute averaged reference intensity is calculated from the decrease of mass of the reservoir over a running 1-minute period. Similarly, the running 1-minute averaged measured intensity is determined by the increase in accumulated precipitation over the corresponding period. Since the sensor and scales a sampled every 10 s, the running 1-minute averaged intensities are also calculated every 10 s. The 1-minute running results for some intensity runs are shown in Figure 12. The dips in the averaged curves of the reference intensity occur 1-minute after start of the test and when the test run is stopped. The labels on the x-axis indicate 1-minute intervals. The results for 2 mm/h show that only in those running 1-minute intervals where the instrument reports an 0.2 mm increment, a corresponding intensity of  $0.2 \text{ mm/min} = 12 \text{ mm/h}$  is generated. Hence the measurements at 2 mm/h jump between 0 and 12 mm/h. Note that the reference intensity at 2 mm/h also show jumps, which are caused by the resolution of the scales. At 50 mm/h the instrument generally reports 3 increments every minute resulting in an intensity of 48 mm/h, but situations with 2 to 5 increments also occur. The effect of these discrete levels becomes less pronounced at higher intensities.

The results at 170 mm/h show a situation where the Alluvion 100 sensor starts emptying continuously 4 minutes after the start of the intensity run. Since no more increments occur, the previous data analysis is restricted to the first 4 minutes since, like for the tipping bucket rain gauges, the analysis is performed over the interval from the first to the last increment/tip. In this situation the errors are much larger when the analysis is performed using the running 1-minute averaged intensities over the period of the intensity run. The panel of 300 mm/h shows a curious behavior that has been only observed in this run. Normally the results at 300 mm/h look good since the contribution of individual increments is negligible. However, in this run the instrument regularly stops reporting precipitation increments and otherwise it largely underestimates the intensity.

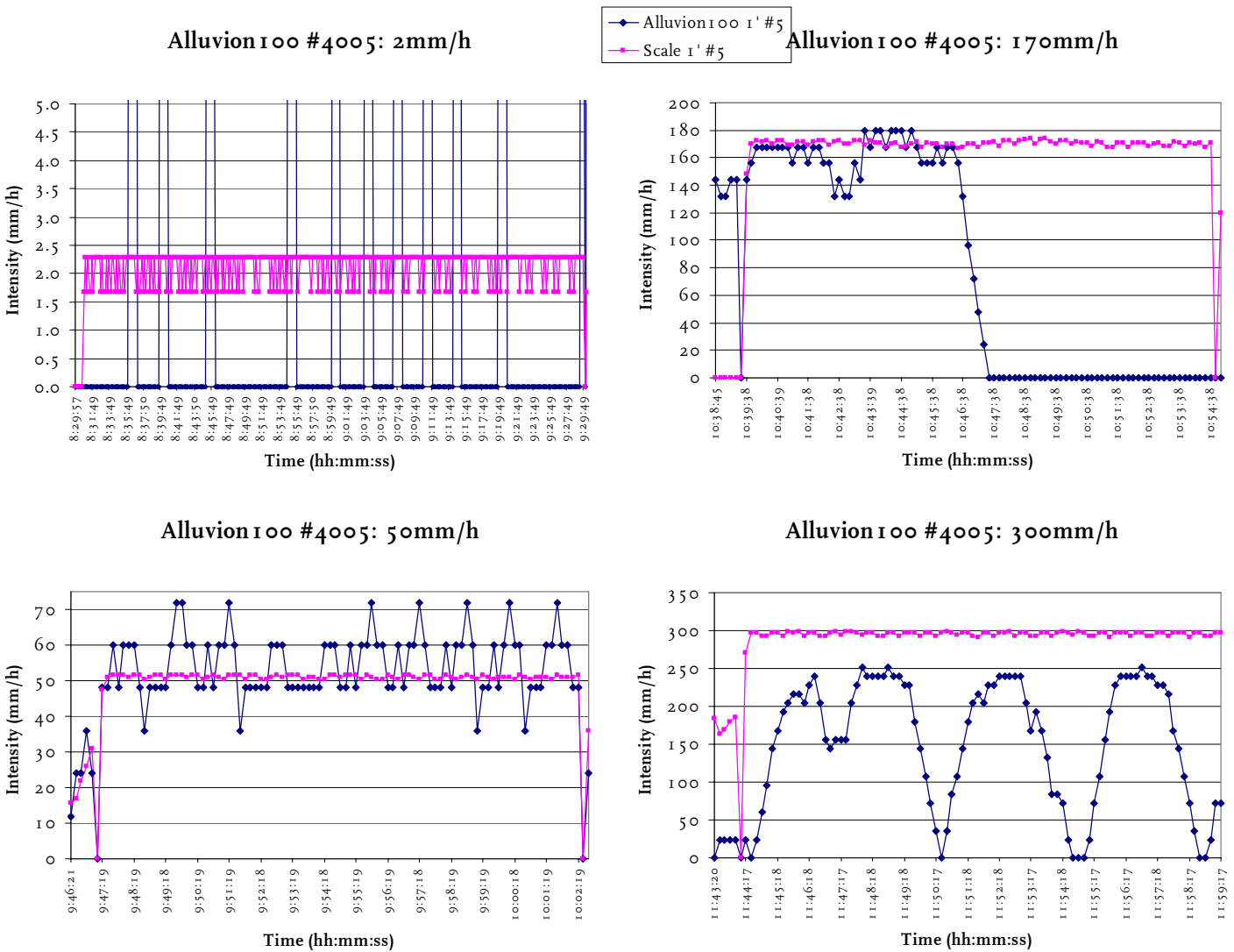

Figure 12: Time series of the running 1-minute averaged reference intensity and the corresponding intensity derived from the Alluvion 100 measurements of run 5 for instrument 4005. Labels in the x-axis denote 1-minute intervals, except at 2 mm/h where a label is given every 2 minutes.

Comments related to the Alluvion 100 sensor are:

- The tests for this instrument were performed with a sample interval of 10 s.
- The evaporation was not measured during this test. An evaporation of 0.07 mm/h was adopted for this test since such evaporation rates have been measured under similar ambient conditions.
- The Alluvion 100 sensor is operational in temperatures between 0 and 65°C. During freezing the instruments stops operating until temperatures rise again.
- Instrument 4002 shows an 18 % underestimation compared to the other sensor. A possible explanation could be an output in 0.1 inch instead of 0.2 mm, which leads to an underestimation of about 11 %. However, the manual and the manufacturer calibration sheet specifically give the output as 0.2 mm.
- Instrument 4005 experienced problems on several occasions during which it siphoned continuously. During these situations the status indicator did not report any failures.

### **3.5. *Meteoservis MRW500***

The MRW500 is a weighing gauge that collects precipitation in an upper vessel with a catching area of 500 cm<sup>2</sup> (diameter of 252.3 mm). This vessel has a capacity of 5 kg, which corresponds to 100 mm of precipitation. The sensor is normally operated with non-freezing liquid and silicone oil to prevent evaporation over long time intervals. The sensor is equipped with pumps in order to discharge water to a lower vessel when the upper vessel is full. In the lower vessel the non-freezing liquid is regenerated and pumped back into the upper vessel where after it is mixed. The lower vessel has a capacity of 90 kg. Normally the upper vessel has a dead weight (LEVEL 0), a capacity of 2.5 kg of regenerated non-freezing liquid (LEVEL 1), a capacity of 1 kg after which the sensor will discharge in case no precipitation is indicated (LIM 1) and a further capacity of 1.5 kg before the sensor discharges regardless the precipitation indicator (LIM 2). For the purpose of this test no with non-freezing liquid and silicone oil are applied and LEVEL 1 and LIM 1 are set to LEVEL 0 and LIM2, respectively in order to be able to use the full 100 mm capacity. The regeneration of the lower vessel is therefore also not used. In addition, the manufacturer decreased the delay of the pulse output after a discharge from 20 to 5 min. This instrument needed to be calibrated after it arrived at KNMI using the reference weights of 0.5 and 3 kg and the software supplied by the manufacturer. The weight of the bucket is measured continuously by a strain gauge. The instrument is equipped with electronics and a serial RS-232 port that reports the accumulated precipitation with a resolution of 0.01 mm. The sensor reported precipitation accumulation after static and dynamic corrections are used in this test. The sensor also has a pulse output with a resolution of 0.1 mm. The manufacturer gives an accuracy of  $\pm 0.1$  mm over the full operational range. The measuring range of the MRW500 is 0 to 400 mm/h.

The test results of the MRW500 sensor are shown in Appendix 5 and are summarized in Figure 12. These results have been obtained by using the reported precipitation accumulation for each intensity run. The results for this sensor show good agreement with the reference and are generally within  $\pm 1$  % except at 2 mm/h where the differences increase to  $-4$  %. The latter is probably the result of evaporation of about 0.09 mm/h,

which, assuming that the evaporation rate of the upper vessel is the same as that of the reservoir, corresponds to  $-5\%$  at  $2\text{ mm/h}$ . The variability of the sensor results is large at  $2\text{ mm/h}$ . The results of sensor A and B are very close to each other. The second order polynomial and the power law fit and their corresponding corrections have been applied to the results. However, in this case the corrections compensate for the underestimation at  $2\text{ mm/h}$  and as a result the errors at  $20$  and  $50\text{ mm/h}$  increase. The behavior of the errors cannot accurately be fitted by a second order polynomial so that at  $2\text{ mm/h}$  the error is only halved whereas at  $400\text{ mm/h}$  the error is overcompensated.

### MRW500

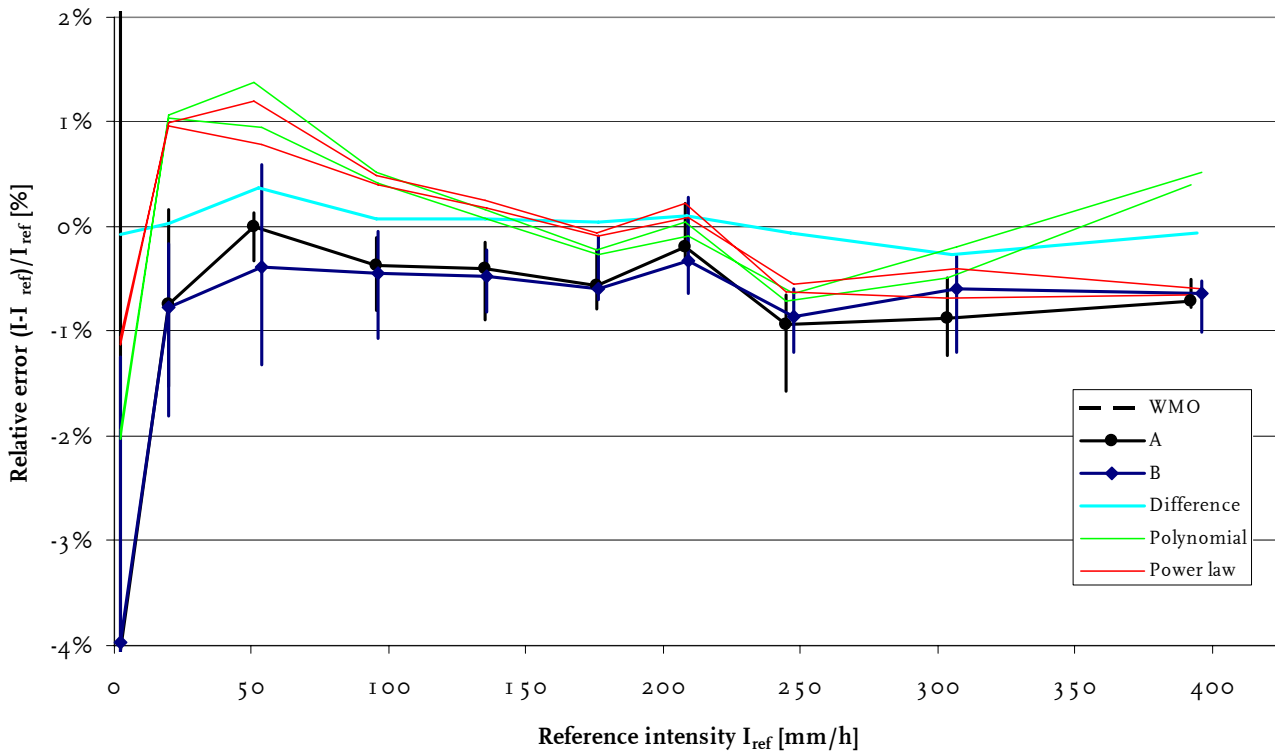

Figure 13: Summary of the test results of the MRW500 instruments showing the averaged test results of both instruments versus the reference intensity, the relative difference between the results obtained for both instruments, and the errors after a correction using the second order polynomial or power law fit has been applied to the data.

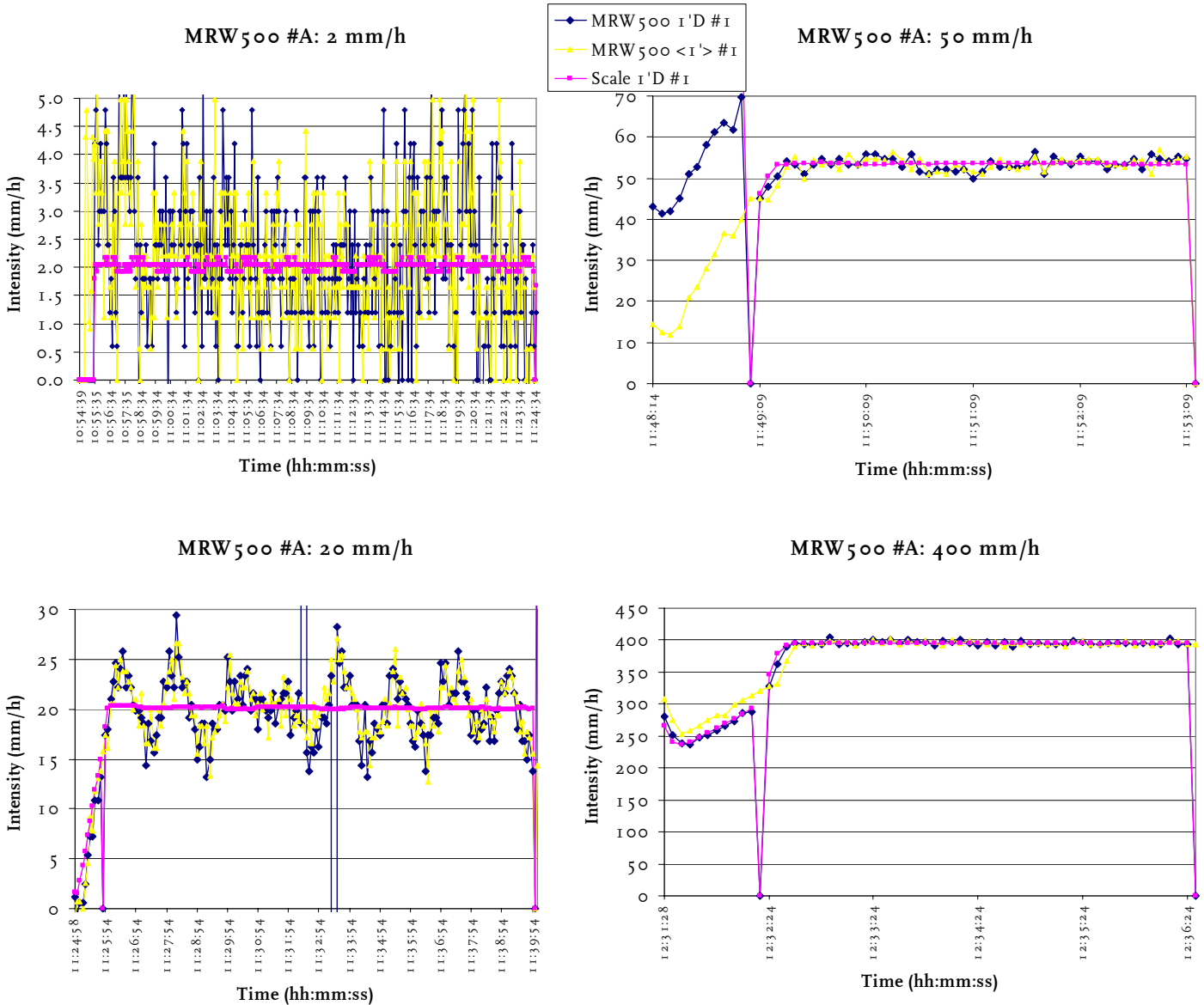

Figure 14: Time series of the running 1-minute averaged reference intensity and the corresponding intensity derived from the MRW500 measurements of run 1 for instrument A.

The 1-minute averaged intensities are calculated for the MRW500 sensor and the reference. The running 1-minute averaged reference intensity is calculated from the decrease of mass of the reservoir over a running 1-minute period. Similarly, the running 1-minute averaged measured intensity, denoted I'D, is determined by the increase in accumulated precipitation over the corresponding period. This intensity is obtained from the difference of 2 sensor readings and is rather noisy. Therefore, the 1-minute averaged intensity, denoted <I'>, is also calculated by averaging the measured 5-second averaged intensities over the corresponding period. Since the sensor and scales a sampled every 5 s, the running 1-minute averaged intensities are also calculated every 5 s. The 1-minute running results for some intensity runs are shown in Figure 14. The labels on the x-axis

indicate 1-minute intervals. The results for 2 mm/h show that both 1-minute averaged intensities of the MRW500 show very large fluctuations in time. Note that the reference intensity at 2 mm/h shows small jumps, which are caused by the resolution of the scale. At 20 mm/h the fluctuations of the instrument are still considerable and vaguely resemble a saw tooth pattern with a period of about 2 minutes. At 50 mm/h the fluctuations are small. The panel for the highest intensity shows a good agreement between reference and sensor values. Figure 14 also shows that the response time of the MRW500 sensor is very fast. When an intensity run is started the MRW15 reports the correct intensity within 20 seconds. Figure 14 also shows a spike for the MRW500 at 20 mm/h. A single faulty sensor reading more than 100 mm larger than the value reported 5 seconds before causes this. The faulty value reports a high precipitation amount for the raw accumulation value as well as for the corrected value with static correction and with static and dynamic correction. However, only during these faulty events the sensor readings with static correction and with static and dynamic correction differed.

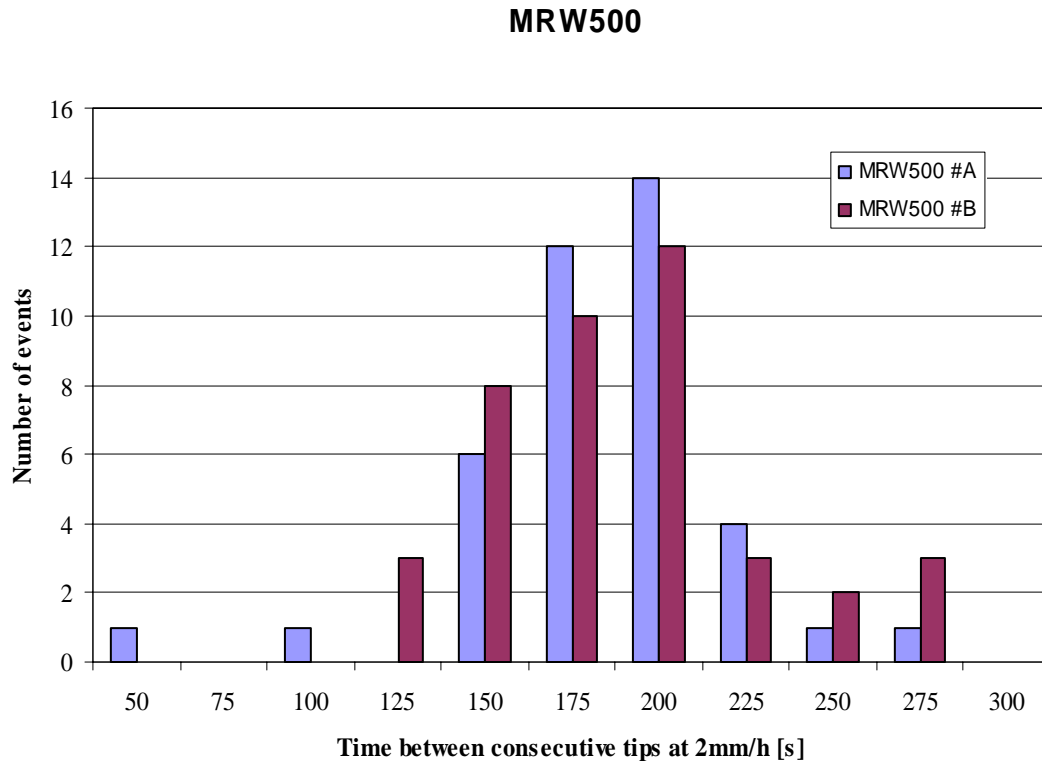

Figure 15: Histogram of the observed time intervals between consecutive increments for both MRW500 instruments at 2 mm/h. The time denoted at the x-axis is the end time of the time interval.

Since the MRW500 sensor also has a pulse output, the results are also processed according to the tipping bucket rain gauges. The results are almost the same for the pulse output as for the intensity output, although the numbers differ. The agreement with the reference is slightly better for the pulse output. In order to be able to compare pulse with intensity results, the overview tables for the pulse output of the MRW500 are also given

in Appendix 5. In addition, Figure 15 shows the distribution of the time intervals between 2 consecutive pulses for all 5 test runs at the reference intensity of 2 mm/h for both MRW500 instruments. The results for both instruments show good agreement and a smooth behavior around the averaged value, except for one entry below 50 s for sensor A. The averaged time between consecutive tips is 172 and 177 s for sensors A and B respectively, which corresponds to intensities of 2.10 and 2.04 mm/h. The standard deviation of the time between consecutive tips is 41 (24) and 38 s (21 %).

Comments related to the MRW500 sensor are:

- The tests for this instrument were performed with a sample interval of 5 s.
- The evaporation of the reservoir on the unused scale was measured for intensities up to 200 mm/h and ranged between 0.05 and 0.13 mm/h. This measured evaporation value is compensated in the data analysis. An evaporation of 0.09 mm/h was adopted for intensity levels above 200 mm/h.
- During the laboratory tests the effect of emptying the collector, which takes about 2 minutes, is not considered. Discharges of the upper vessel were avoided by inserting manual discharges by applying force on the upper vessel in between intensity runs. After such a discharge a pause was inserted.
- The MRW500 sensor is operated in this test differently than under normal operation. Specifically, reducing the amount of non-freezing water that is pumped back into the collector and eliminating the first emptying level enhanced the capacity of the sensor. Furthermore, the unavailability of the pulse output after emptying the collector is reduced.
- The MRW500 required a calibration after installation, which is not practical in the field.
- The calibration procedure step for the determination of “sucking air level of water in the collector when emptying” depends on whether the collector is emptied or when it is filled in small steps followed by emptying trials.
- The adjustment of the string when the collector is empty (pump sucks air) could not be set to the reported range of 8000-8500 g for sensor A, but was about 6400. For sensor B the weight could be regulated within the required range.
- During the laboratory tests the serial output sometimes gave faulty readings that also show up in the raw data output. In these cases the static and dynamic corrected results differ whereas they are the same for all other measurements.
- The data output of the MRW is binary and therefore not user friendly. There is no need for such a binary output since the size of the data string is not large.
- The command “x10 x01 x22 x04 x45” is used to poll the instrument, but copying/pasting this string via Hyperterm does not work. According to the manufacturer the delay between the individual characters has to be minimal.
- The measuring range is not mentioned in the supplied documentation.
- The software version of the sensor is not reported in the manual nor is it given by the sensor interface.
- The format of other commands like e.g. x21 is not specified in the documentation and was not provided by the manufacturer upon request; hence the user does not know when the sensor is being emptied. This is not suitable for out door usage.

- When there is an interruption of the power supply of the sensor, the emptying of the sensor by applying pressure to the collector does not work anymore. Hence, after the interruption the weight corresponding to a nearly full collector seems to be lost so that the automatic emptying when the collector is nearly full does not work anymore.
- Since the precipitation falls directly into the collector, there is some spatter at high intensities.

### 3.6. *Meteoservis MR3H-FC*

The MR3H-FC is a tipping bucket rain gauge with a resolution of 0.1 mm and the collector diameter is 252.3 mm. The instrument has a reed switch output and next to this uncorrected output it also gives a corrected output. The sensor contains a microprocessor that analyses the measured tip frequency and introduces additional tips to the measured tips in order to compensate for the well-known underestimation at higher intensities. Both the uncorrected and the corrected output are acquired and stored every 10 s. The user's guide does not state the accuracy of the rainfall rates obtained by the sensor. The measuring range is 0 to 500 mm/h.

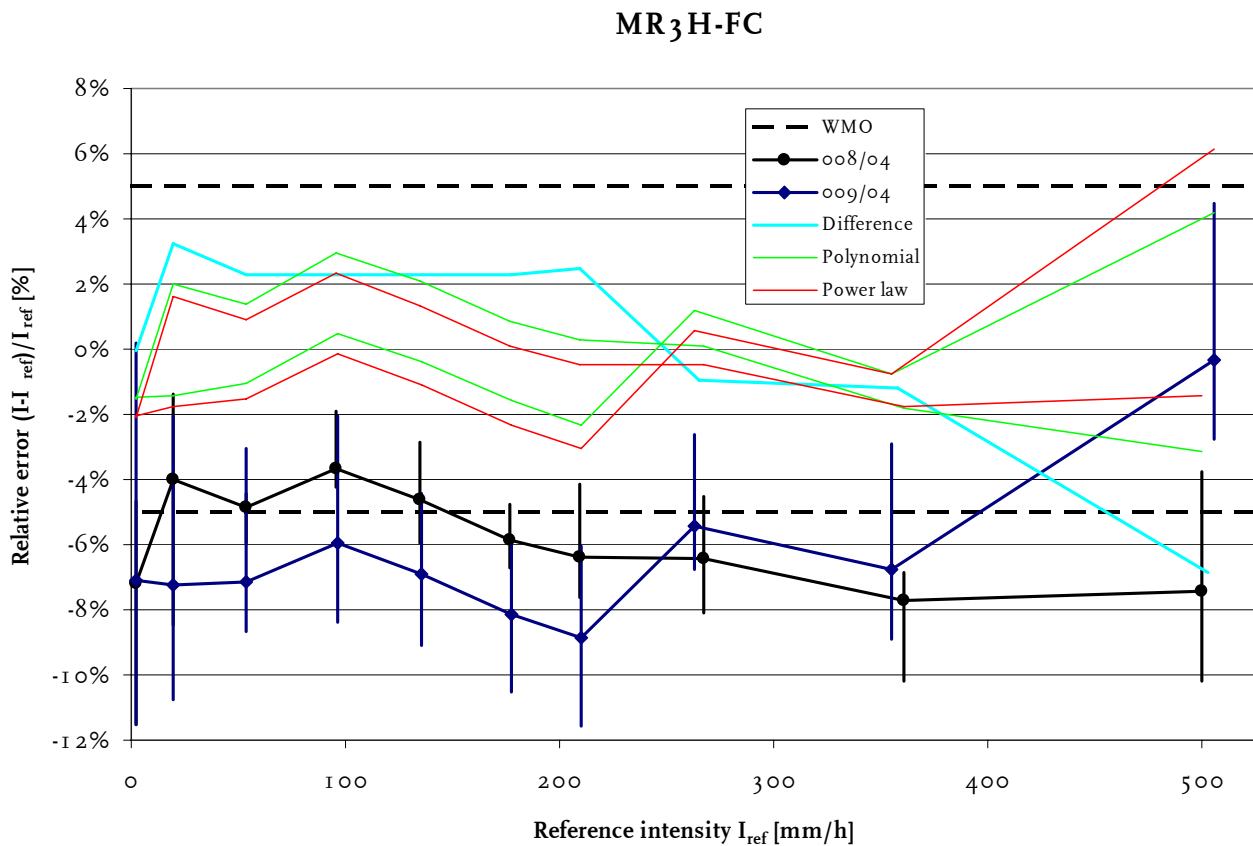

Figure 16: Summary of the test results of the corrected output of the MR3H-FC instruments showing the averaged test results of both instruments versus the reference intensity, the relative difference between the results obtained for both instruments, and the errors after a correction using the second order polynomial or power law fit has been applied to the data.

The test results of the MR3H-FC sensor are shown in Appendix 6 and are summarized in Figure 16. The corrected output of this sensor does not show the underestimation of precipitation at high intensities. Although the MR3H-FC does not show this well-known behavior typical for tipping bucket rain gauges, both instruments underestimate precipitation by about 4-8 % at all intensities. The two MR3H-FC instruments differ from one another by about 2-3 % at low intensities. At 500 mm/h the results of sensor 1 underestimate precipitation by about 7 %, but sensor 2 shows almost no deviation. A correction by the second order polynomial or the power law fit places the results of the MR3H-FC sensor within  $\pm 3\%$  of the reference intensity, except for the reference intensity of 500 mm/h where the differences after correction reach values up to 4 % and 6 % for the second order polynomial or the power law, respectively.

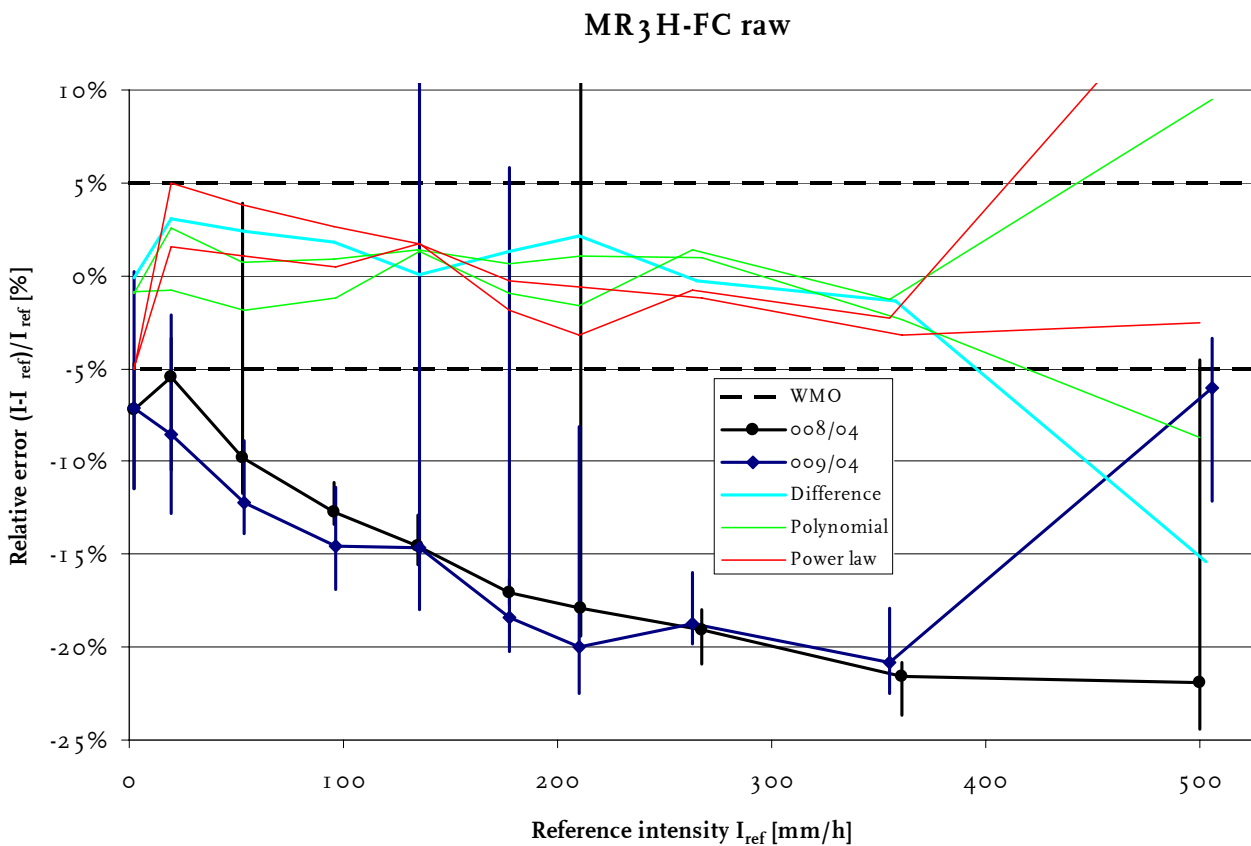

Figure 17: Same as Figure 16, but now for the raw read output of the MR3H-FC instruments.

The raw output of the MR3H-FC sensor, cf. Figure 17, shows the well-known underestimation of precipitation of tipping bucket rain gauges. The large deviation in some measurements are caused by faulty raw tips, during which significantly more pulse are generated than the corrected pulse output. The differences between the raw results of both instruments are somewhat larger than the corrected results, particularly at 500 mm/h.

A correction by the second order polynomial or the power law fit places the results of the MR3H-FC sensor within  $\pm 3\%$  of the reference intensity, except for the reference intensity of 500 mm/h.

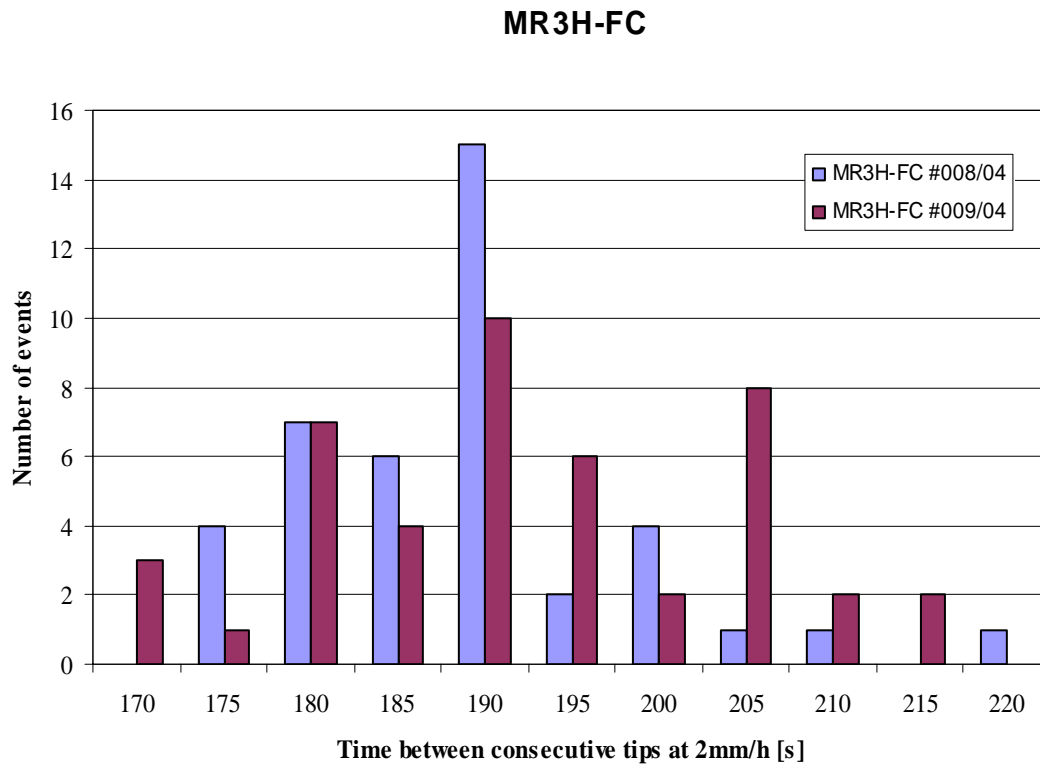

Figure 18: Histogram of the observed time intervals between consecutive tips for both MR3H-FC instruments at 2 mm/h. The time denoted at the x-axis is the end time of the time interval.

Figure 18 shows the distribution of the time intervals between 2 consecutive tips of the corrected output of the sensor for all 5 test runs at the reference intensity of 2 mm/h for both MR3H-FC instruments. The figure shows that the distribution of the tip intervals for sensor 1 and 2 are roughly the same. However, the distribution of sensor 1 shows a pronounced peak at 190 s, whereas the distribution of sensor 2 is broader and has a secondary peak at 205 s. The averaged time between consecutive tips is 187 and 186 s for sensors 1 and 2 respectively, which corresponds to intensities of 1.92 and 1.93 mm/h. The standard deviation of the time between consecutive tips is 10 (5) and 24 s (13 %), respectively.

Comments related to the MR3H-FC sensor are:

- The tests for this instrument were performed with a sample interval of 10 s.
- The evaporation of the reservoir on the unused scale was measured for intensities up to 200 mm/h and ranged between 0.03 and 0.06 mm/h. This measured evaporation value is compensated in the data analysis. An evaporation rate of 0.05 mm/h was adopted for intensity levels above 200 mm/h.

- The tips occur irregularly at high intensities.
- Calibration certificates are provided for the temperature controls of the heating, but the reported serial numbers do not coincide with the serial numbers of the sensors.
- The accuracy of the precipitation intensity is not reported.
- The hole in the funnel is very small and debris easily gathers and might block or delay the entry, the manufacturer reports a maintenance check every 3 days!
- The tipping bucket was not fixed during transport although it is mentioned in the manual.
- The software version of the sensor is not reported in the manual nor is it given by the sensor interface. Details of the applied correction are also not available.
- At the lowest precipitation intensity the water does not enter the tipping bucket via the middle of the inlet, but enters underneath the ring.
- About 1-2 cm of precipitation accumulates in the funnel at intensities of 500 mm/h, but not at 368 mm/h. The accumulated water causes about 9 tips after the pump stops.
- The usage of the spring does not lead to larger accumulation of water at high intensities, but when the sensor/spring are dry it causes a delay at low intensities.
- During the test the raw tips sometimes caused a large number of faulty events. These events are identified when the number of corrected pulses is below the number of raw pulses. The faulty events are corrected by using the number of corrected pulses instead.
- After the runs with a reference intensity of 500 mm/h there is some spatter in the sensor.

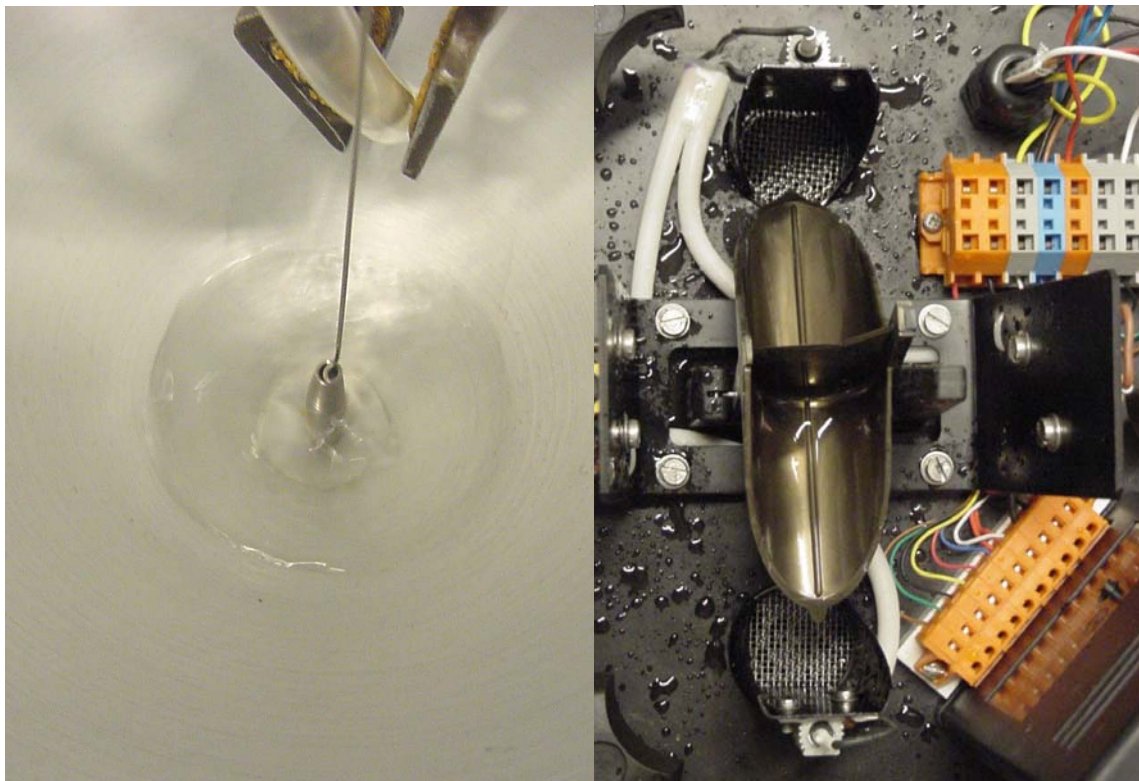

Figure 19: Photographs of the accumulation of water in the funnel at 500 mm/h (left) and the spatter inside the sensor (right).

### 3.7. Vaisala VRG101

The VRG101 sensor is a weighing gauge with a catching area of 400 cm<sup>2</sup>. The precipitation is captured directly in a collector with a capacity of 30 l, which corresponds to 750 mm of precipitation. The instrument is equipped with electronics and a serial RS-232 port. The internal software computes the 1-minute averaged precipitation intensity, which is reported with a resolution of 0.01 mm/h and is updated once every minute. The measuring range of the VRG101 sensor is 0 to 2000 mm/h.

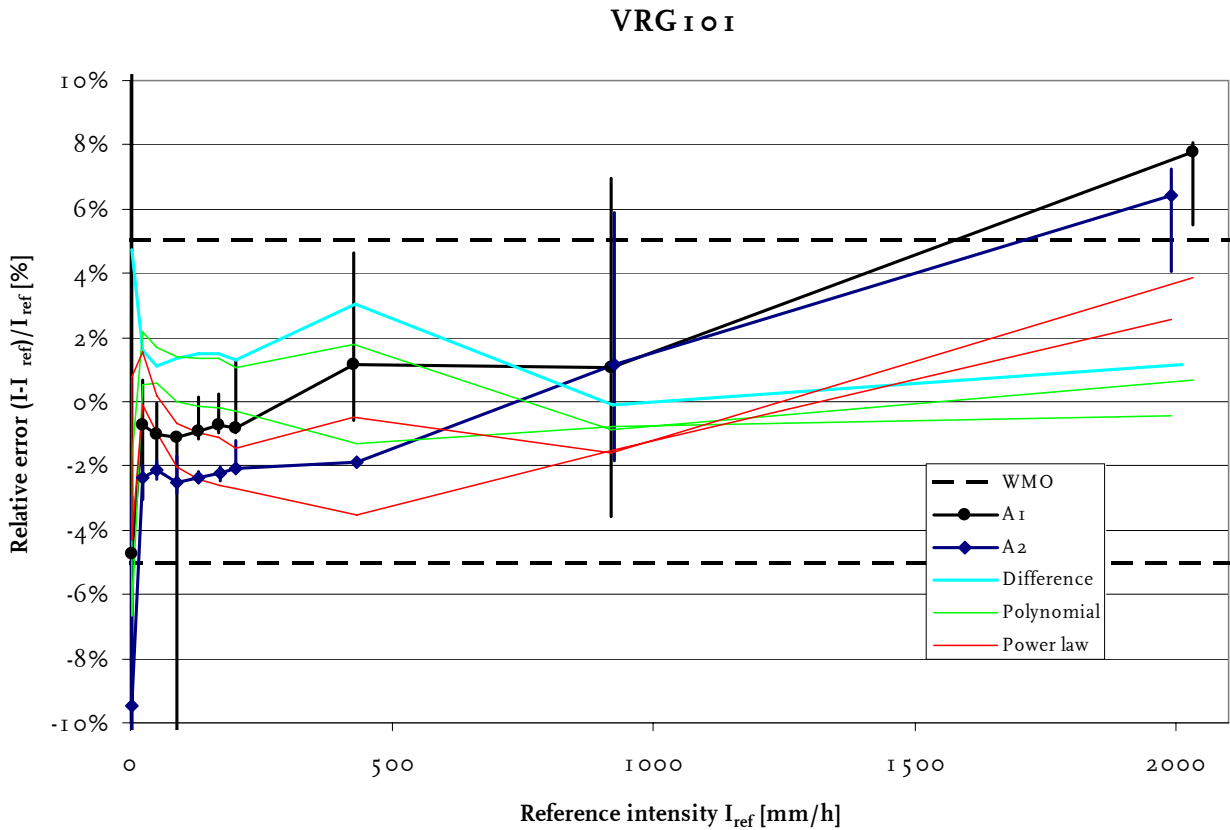

Figure 20: Summary of the test results of the VRG101 instruments showing the averaged test results of both instruments versus the reference intensity, the relative difference between the results obtained for both instruments, and the errors after a correction using the second order polynomial or power law fit has been applied to the data.

The test results of the VRG101 sensor are shown in Appendix 7 and are summarized in Figure 20. These sensor results have been obtained by averaging the reported precipitation intensity for each intensity run. The results for the first 5 minutes after the start of the intensity run are ignored in order to overcome the delay of the sensor. At 2 mm/h a delay of 7 minutes was used. The results are almost everywhere within the  $\pm 5\%$  limits from the reference intensity. Only at 2000 mm/h both instruments show an overestimation of +8 and +6% and at 2 mm/h both instruments show large scatter in the results and an underestimation of -5 and -9%. The agreement between the results of

sensor 1 and 2 is generally good, except at 2 mm/h where they differ by about 5 %. The second order polynomial and the power law fit and their corresponding corrections have been applied to the results. The corrections compensate for the overestimation at 2000 mm/h, but the large deviation at 2 mm/h is correctly. The large deviation of sensor A1 at 90 mm/h for run 4 is caused by a too small reference intensity at the start of the run so that the sensor results were not stabilized after 5 minutes.

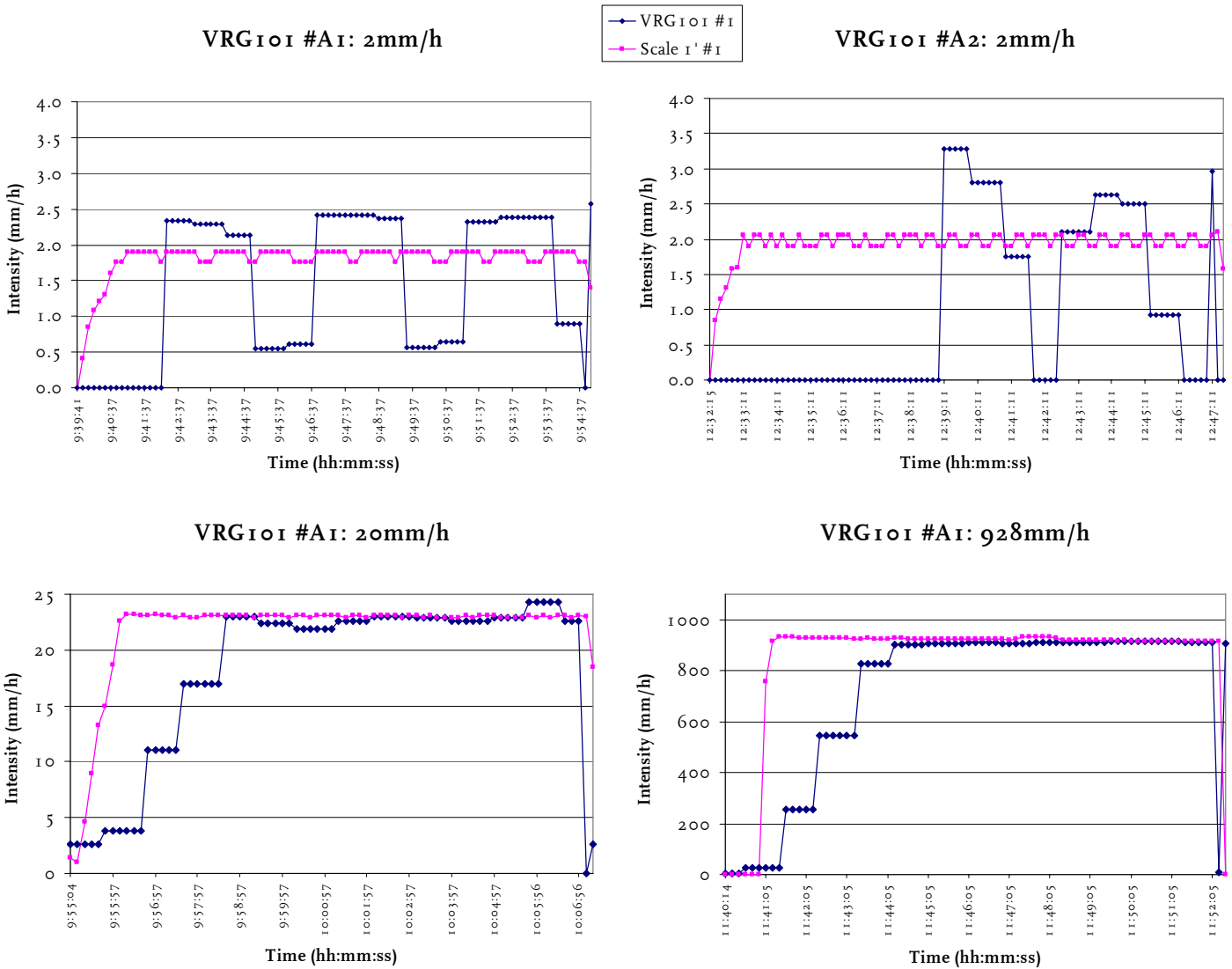

Figure 21: Time series of the running 1-minute averaged reference intensity and the corresponding measurements of the VRG101 of run 1 for instruments A1 and A2.

The 1-minute averaged intensities of the VRG101 sensor and the reference are shown in Figure 21 for some intensity runs. The running 1-minute averaged reference intensity is calculated from the decrease of mass of the reservoir over a running 1-minute period and the sensor value is taken directly from the sensor output. The labels on the x-axis indicate 1-minute intervals. The results for 2 mm/h show the large variability in the sensor results

and the delay of up to 7 minutes. At reference intensities of 20 mm/h and higher the delay of the sensor is 5 minutes and the variability of results of the instrument is less.

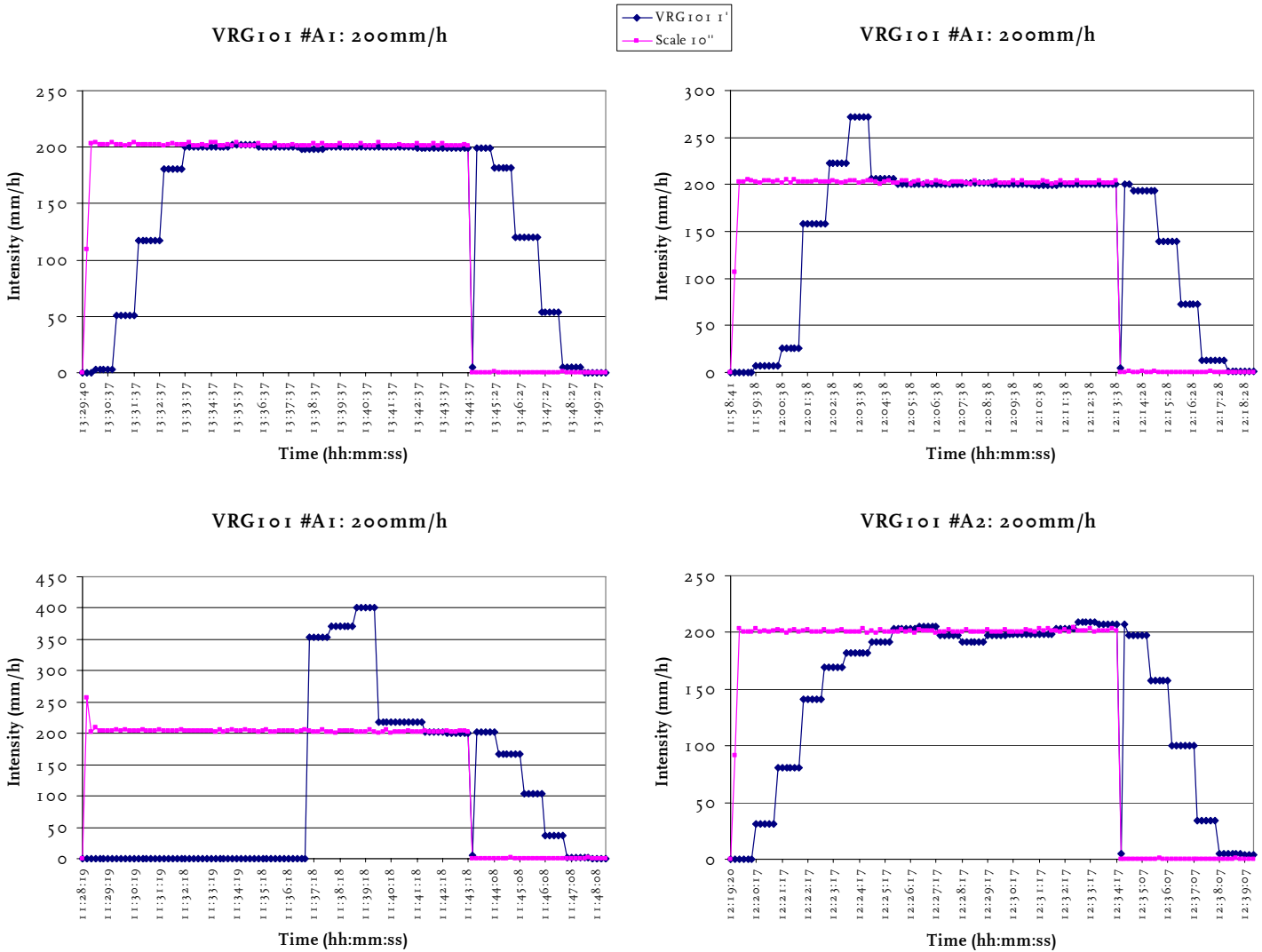

Figure 22: The results of various step response runs of the VRG101 sensor at 200 mm/h.

Figure 22 shows the results of applying a step function to the VRG101 sensor. A pause of at least 7 minutes was introduced before and after the step in order to allow the sensor to come to rest. The results clearly show the sensor delay of 5 minutes before the correct precipitation intensity is reported. After the end of the step another 5 minutes is required before the sensor value returns to zero. The various tests show a different behavior. In the upper left panel the sensor reports the correct intensity after 5 minutes without an overshoot, whereas in the upper right panel such an overshoot can be observed. In the lower left panel the delay of the sensor is 9 minutes followed by 3 minutes of overshoot. It should be noted that such a long delay was observed only in this case. The lower right panel shows an example of the response of instrument A2 to a step of 200 mm/h. For all tests with this instrument the sensor response goes more slowly to the correct intensity

and even then the reported intensity shows fluctuations around the reference value. In all step response tests the precipitation sum over the period from the very start of the step up to 5 minutes after the end of the step, when the sensor returned to zero, differed less than 1 to 2 % from the reference value of about 50 mm.

Comments related to the VRG101 sensor are:

- The tests for this instrument were performed with a sample interval of 10 s.
- The evaporation of the reservoir on the unused scale was generally measured for intensities up to 200 mm/h and ranged between 0.04 and 0.09 mm/h. This measured evaporation value is compensated in the data analysis. An evaporation of 0.05 mm/h was adopted for intensity levels above 200 mm/h.
- During the test care needed to be taken so that the collector did not touch the inner part of the funnel.



Figure 23: Photograph of the collector of the VRG101 sensor and the housing.

### **3.8. Serosi Nilometre**

The Nilometre sensor is a rain gauge, which measures the amount of precipitation by means of a water level measurement. The sensor has with a catching area of 400 cm<sup>2</sup> and leads the water via a funnel and an internal collector to a reservoir. The water level in the reservoir is measured by means of conductivity. The resolution of the water level measurement is equivalent to 0.01 mm. The instrument is equipped with electronics and a serial port. The sensor reports the accumulated water level. Details of the communication

and data available from the sensor are unknown. The manufacturer did not give any details upon request. Instead software was provided by the manufacturer, which was installed on a dedicated PC that used one COM port to communicate with the sensor and reported the accumulated precipitation amount with a 0.01 mm resolution on another COM port. The accumulated precipitation amount is updated once per minute. The Nilometre detects when the reservoir is full, in which case the connection between the internal collector and the reservoir is closed and the reservoir is emptied by a pump. Once the reservoir is empty, the pumps stop and the connection between the internal collector and the reservoir is opened so that the water that accumulated in the inner collector during emptying of the reservoir is released for measurement. The capacity of the inner collector determines the maximum intensity of the instrument, because it overflows for intensities above 200 mm/h. The capacity of the reservoir is equivalent to about 7 mm. The measuring range of the Nilometre sensor is 0 to 200 mm/h.

### Nilometre

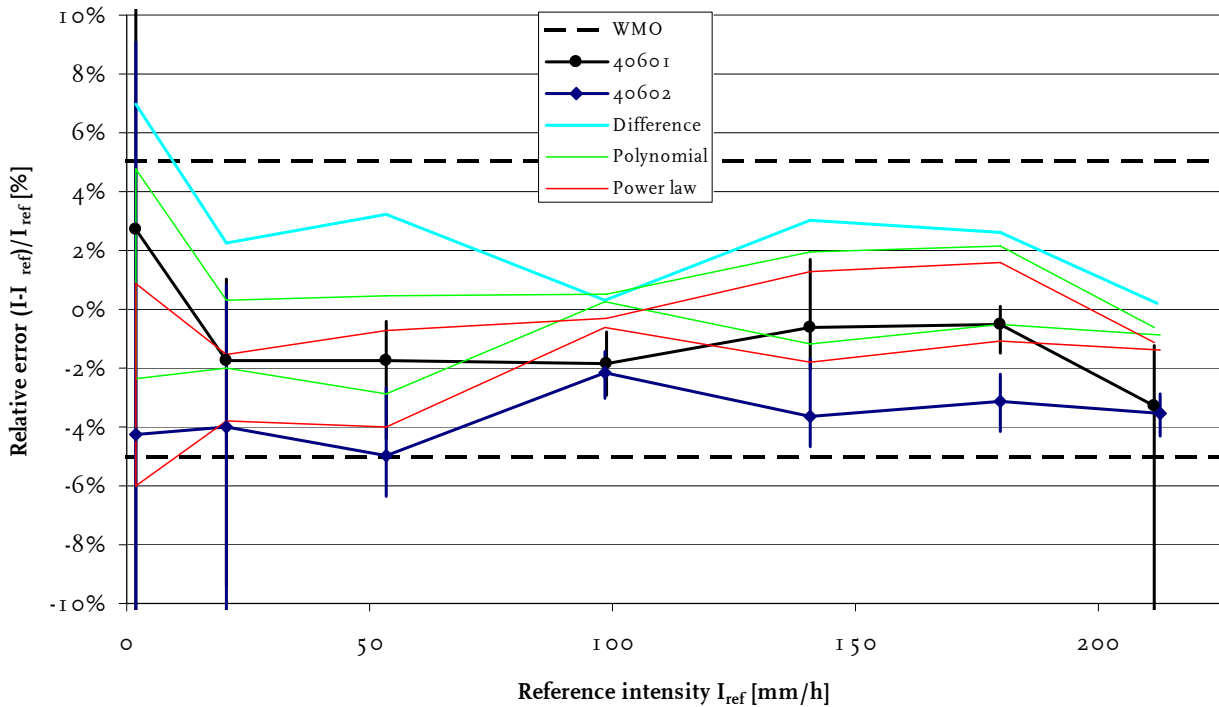

Figure 24: Summary of the test results of the Nilometre instruments showing the averaged test results of both instruments versus the reference intensity, the relative difference between the results obtained for both instruments, and the errors after a correction using the second order polynomial or power law fit has been applied to the data.

The test results of the Nilometre sensor are shown in Appendix 8 and are summarized in Figure 24. These sensor results have been obtained by computing the precipitation intensity from the increase in the reported accumulated precipitation level from 15 sec

after the start up to the end of the intensity run where the actual range is further restricted to the first and last new sensor report within this range. The results are almost everywhere within the  $\pm 5\%$  limits from the reference intensity, except at 20 and 50 mm/h where instrument 2 shows an underestimation of  $-6\%$ . Both instruments underestimate the reference precipitation amount, by about  $-2\%$  and  $-4\%$  for sensor 1 and 2, respectively. The agreement between the results of sensor 1 and 2 is between 1 and 4%, but sensor 2 generally gives 2% lower sensor readings. Note the large variability of the sensor results at 2 and 20 mm/h. The large error bar at 200 mm/h for sensor 1 is caused by overflow of the sensor in run 3. A combination of a high reference intensity and timing of the check for emptying resulted in exceeding the maximum level of the sensor after which water is lost via an overflow outlet. The second order polynomial and the power law corrections put all results within the  $\pm 5\%$  limits.

The results in Appendix 8 and Figure 24 were obtained by calculating the intensity from the difference in accumulated water reported by the sensor over a fixed time interval within the period of the intensity run and comparing that to the reference intensity obtained by the decrease in mass of the reservoir on the scales. Such an intensity derived from differences over the period of the test corresponds with the way the intensity has been calculated for other sensors. As for tipping bucket sensors the range is restricted to the first and last sensor update because otherwise precipitation supplied before the first and after the last sensor update are not correctly taken into account. This effect is ignored when the differences are calculated by comparing the averages of the running 1-minute averaged values of sensor and reference over the period of the test run. In that case the results from the sensor and the reference are taken with a delay of 2 minutes since it may take up to 1 minute for the sensor to report the first level after start of the intensity run, and then another minute for the first increment of the level from which the 1-minute averaged intensity during constant flow can be derived. The relative errors obtained from the differences and the averages mentioned above are reported in Figure 25. The solid curves correspond to results given in Appendix 8 and Figure 24. It can be noted that the results obtained by averaging shows large differences that are generally outside the  $\pm 5\%$  limits for precipitation intensities above 50 mm/h. In these situations the sensors always report less precipitation compared to the reference. The reason for this is not only the water provided before and after the first and last sensor update, respectively, but it is amplified by the variability of the sensor results. This variability is reported in a table in Appendix 8 and is discussed in more detail in Figure 26. Another way to test the performance of the sensor is to compare the total precipitation sums supplied by the reference and reported by the sensor. In order to be able to do this, intensity runs were performed in such a way that a delay was introduced before and after each run. The relative differences of the precipitation sums are also shown in Figure 25. The agreement of the precipitation sums is good and generally follows the results obtained for the intensities obtained between the first and last sensor update.

## Nilometre

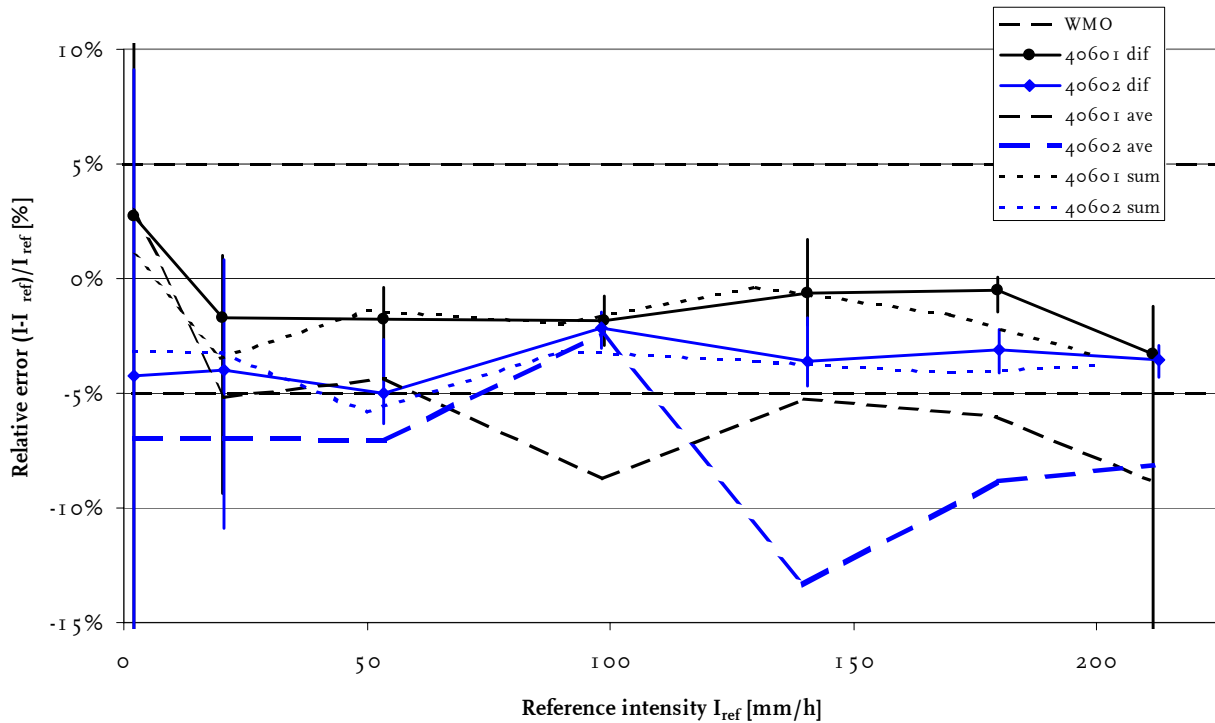

Figure 25: Summary of the test results of the Nilometre instruments showing the averaged test results of both instruments versus the reference intensity for the cases: (solid lines) when the intensities are derived from the changes from the first to the last sensor update; (long dash) when the intensities are averages from the running 1-minute averaged data over the full interval of the test run, but taking account of a 2-minute delay; (short dash) when the total precipitation sums are calculated including a 2-minute delay after the end of the intensity run.

The 1-minute averaged intensities of the Nilometre sensor and the reference are shown in Figure 26 for some intensity runs. The running 1-minute averaged reference intensity is calculated from the decrease of mass of the reservoir over a running 1-minute period and the sensor value is derived from the change in accumulated water level reported by the sensor over that minute. The labels on the x-axis indicate 1-minute intervals. The results for 2 mm/h show a large variability in the sensor results. At 20 mm/h there is also considerable variability, especially after emptying of the reservoir. As a result of emptying the sensor reports no precipitation during one minute and reports twice the amount of precipitation in the next 1-minute interval. The interval without precipitation is caused by the fact that the sensor measures the water level of the reservoir only once per minute, and after emptying this level corresponds to a new zero level. Afterwards the water accumulated in the internal collector during emptying is released. At the next minute interval the water level increment corresponds to the amount of water collected during the last 2 minutes. At higher reference intensities the variability of the sensor becomes less, but emptying occurs more often and at 200 mm/h emptying occurs almost

every 2 minutes. Hence, the sensor reports either 0 mm/h or 400 mm/h at 200 mm/h. The curves also show that the delay of the sensor is 2 minutes, since 2 water level measurements are required and the sample rate of the sensor is 1 minute.

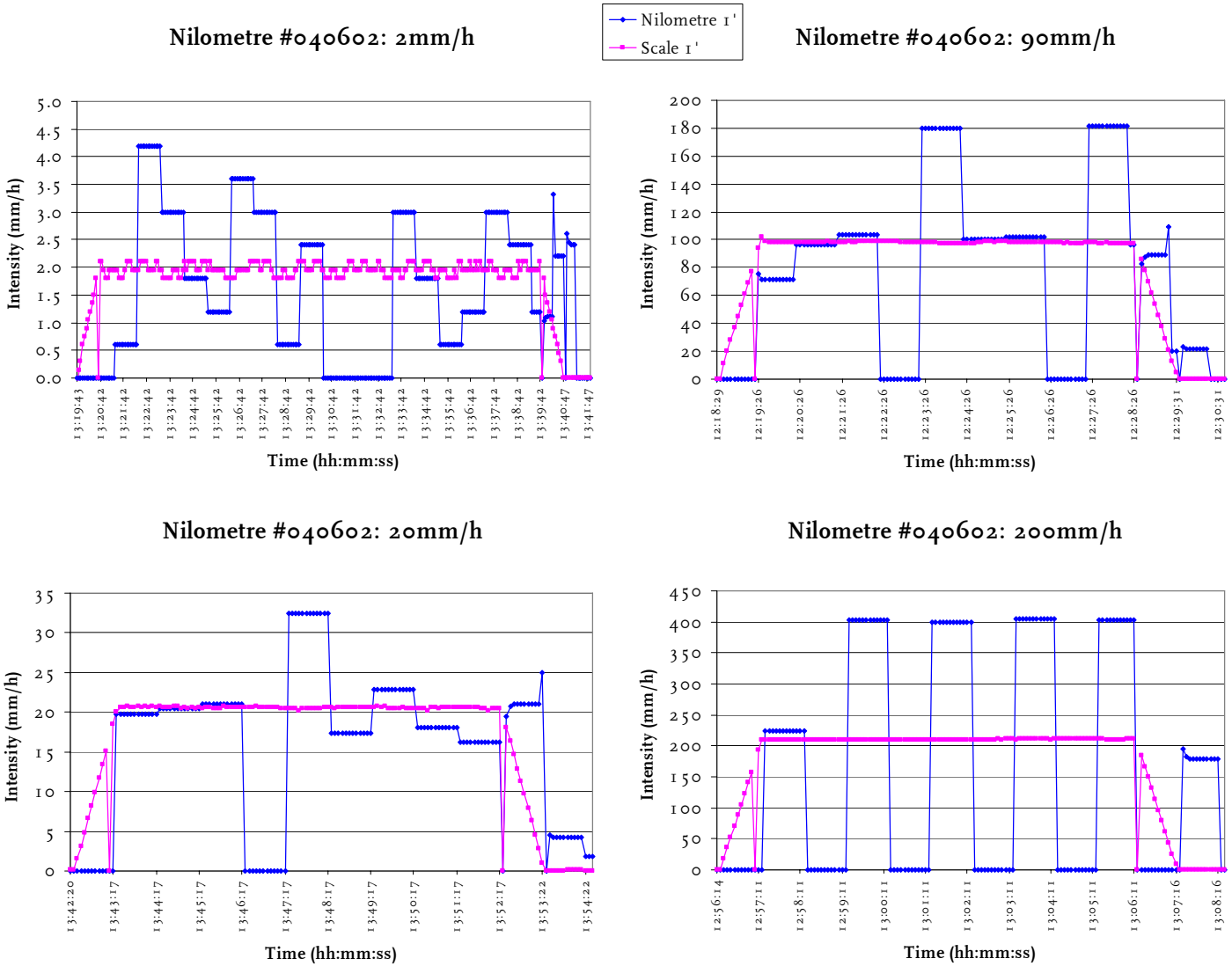

Figure 26: Time series of the running 1-minute averaged reference intensity and the corresponding measurements of the Nilometre instrument 040602 run 4.

Comments related to the Nilometre sensor are:

- The tests for this instrument were performed with a sample interval of 5 s.
- The evaporation of the reservoir on the unused scale was measured and ranged between 0.04 and 0.10 mm/h. This measured evaporation value is compensated in the data analysis. The typical evaporation rate is about 0.07 mm/h.

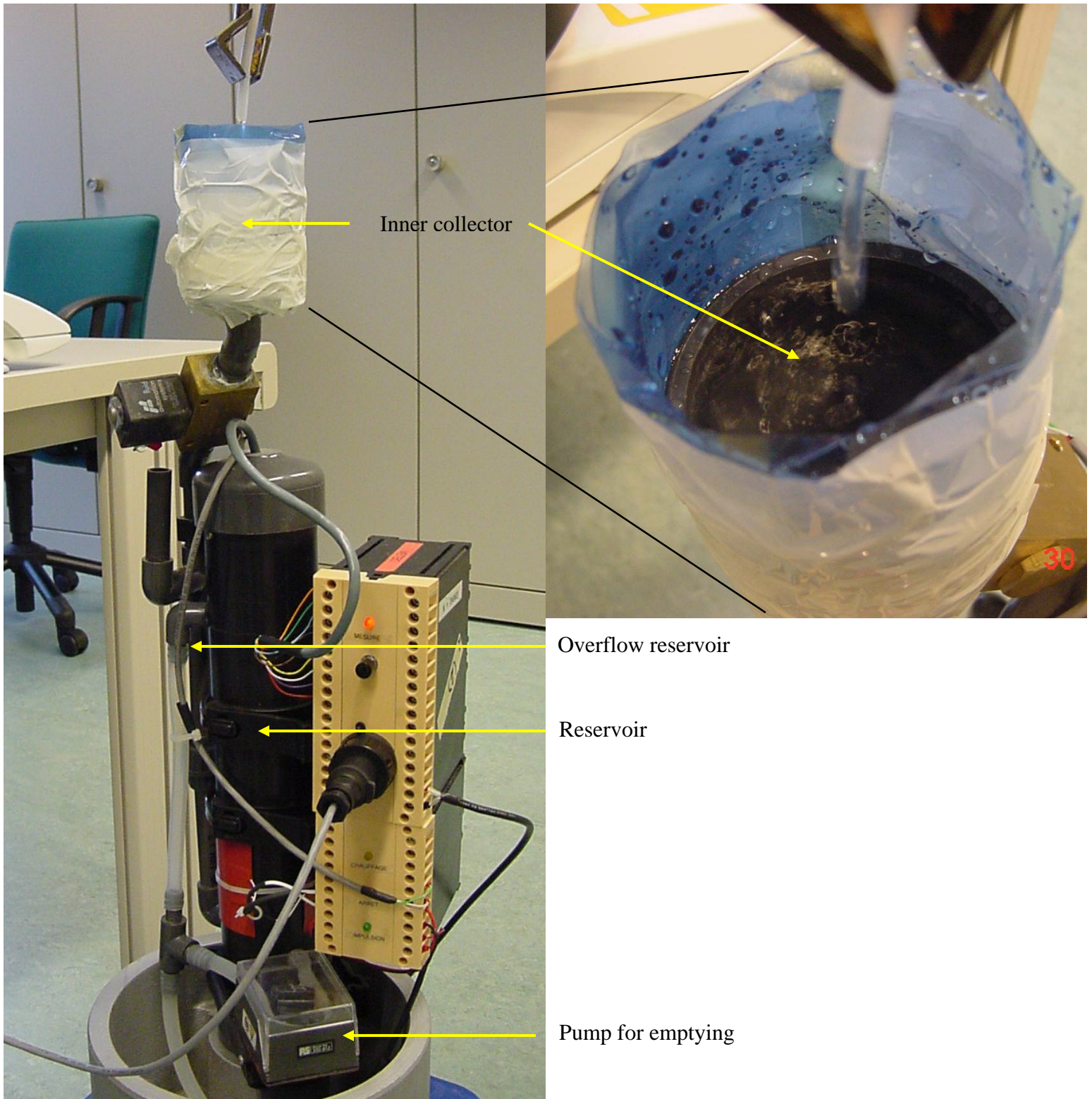

Figure 27: Photograph of the interior of the Nilometre sensor and the inner collector nearly full at the end of emptying at 200 mm/h.

- The laboratory test could not be performed with tap water because the conductivity needed to be below 200  $\mu\text{S}/\text{cm}$ . Therefore distilled water was used. During the runs the conductivity was always below 10  $\mu\text{S}/\text{cm}$ , and generally about 6  $\mu\text{S}/\text{cm}$ .
- No manual was supplied with the Nilometre sensor. The manufacturer did not make the specifications of communication with the instrument available. Instead the manufacturer provided software for communication with the instrument. This software reported only the water level once per minute. The software version of the Serosi software is 47E.
- At the minute (just after a new measurement) the sensor checks whether the reservoir is full and needs to be emptied. During emptying precipitation is collected in the inner collector. The capacity of this collector corresponds to 200 mm/h, at higher intensities the inner collector overflows. The next minute emptying is completed, the new level of the reservoir is determined and the water accumulated in the inner collector is released into the reservoir. During the minute emptying occurs no precipitation is recorded. The precipitation accumulated during emptying is measured and reported the next minute.
- At the minute (just after a new measurement) the sensor checks whether the reservoir is full and needs to be emptied. A situation occurred for sensor 040602 in run 3 when at 200 mm/h the reservoir overflowed before the next check of the level was performed. Overflow of the inner collector or the reservoir is not detected by the sensor and causes an underestimation of precipitation.
- Overflow of the inner collector releases the water in the sensor interior, which might cause damage.
- The inner collector of instrument 040602 was broken during transport. Hence the collector and the associated shutter were replaced with that of 040601 before performing the test.
- On one occasion Nilometre instrument 040601 reported a faulty precipitation accumulation of 2.6 km and emptied continuously. The sensor worked properly again after a reset.
- Some spatter occurs during the accumulation of precipitation in the inner collector when emptying.

### **3.9. Ott Hydrometrie Pluvio 250**

The Pluvio 250 is a weighing gauge that collects precipitation directly in a collector with a catching area of 200  $\text{cm}^2$  ( $\pm 0.5\%$ ), i.e. a diameter between 159.18 and 159.98 mm. The collector has a capacity of 250 mm of precipitation. Precipitation falls directly into the collector, except the precipitation that hits the rim. The collector is situated on top of a weighing mechanism. The weight of the collector is measured internally every 6 seconds with a resolution corresponding to 0.01 mm of precipitation. Every minute the raw measurements are processed in a filter algorithm in order to eliminate faulty precipitation events caused by e.g. wind effects. The delay in the reporting of precipitation is 7 minutes for low precipitation rates and 4 minutes for intensities above 6 mm/h. The threshold for reporting precipitation is 0.03 mm in 40 minutes, i.e. 0.045 mm/h. The internal software also applies correction for the temperature dependence of the weighing mechanism. The instrument is equipped with electronics and a serial RS-422 interface that reports the collector content (mm), the accumulated precipitation amount (mm) and the precipitation

intensity (mm/min) with a resolution of 0.01 mm. The sensor also reports status information. When the collector is nearly full an alarm is generated indicating that the collector needs to be emptied. Emptying needs to be performed manually. An error is reported when the collector mass is too high. The manufacturer gives an accuracy of  $\pm 0.04$  mm for 10 mm of precipitation. The measuring range of the Pluvio 250 is 0 to 1200 mm/h.

Pluvio 250

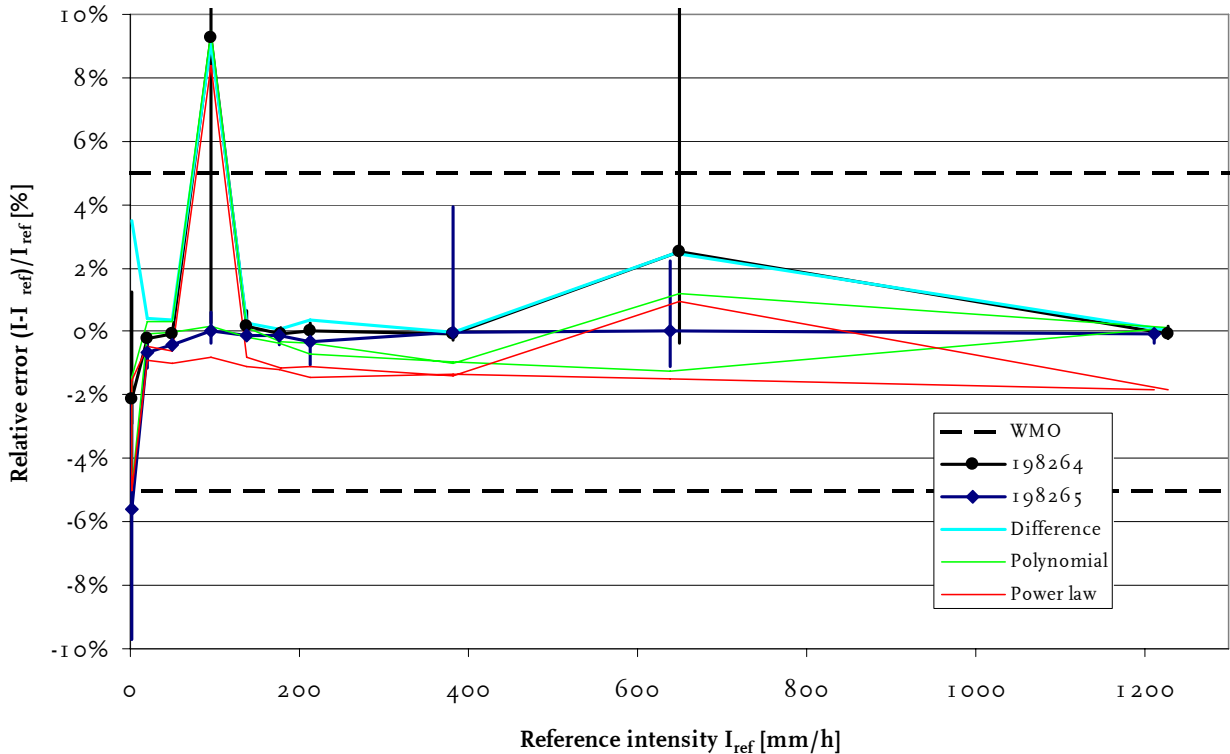

Figure 28: Summary of the test results of the Pluvio 250 instruments showing the averaged test results of both instruments versus the reference intensity, the relative difference between the results obtained for both instruments, and the errors after a correction using the second order polynomial or power law fit has been applied to the data.

The test results of the Pluvio sensor are shown in Appendix 9 and are summarized in Figure 28. These results have been obtained by averaging the reported 1-minute averaged precipitation intensity for each intensity run. The first 8 minutes of the intensity run are ignored in order to account for the filtering delay of the sensor. The remaining interval is further restricted to the period between the first and last sensor update. The results for this sensor show generally very good agreement with the reference within  $\pm 1\%$  except at 2 mm/h where the differences increase to  $-2$  and  $-6\%$  for sensors 1 and 2 respectively, and at 90 and 660 mm/h where sensor 1 shows errors up to  $+9$  and  $+3\%$ , respectively. The first is the result of evaporation. The ambient temperature during the laboratory tests was

high and the measured evaporation rates showed values between 0.1 and 0.3 mm/h. The evaporation is taken into account when calculating the reference intensity. However, the evaporation of the collector of the sensor is not taken into account. Hence the sensor underestimates precipitation. The large differences at 90 and 660 mm/h are caused by the delay of the sensor. Instead of the expected delay of 8 minutes a delay up to 11 minutes was observed in these situations. Since the sensor generally gives an overestimation of the precipitation rate at the onset of precipitation in order to make up for the delay, this explains the overestimation of the averaged sensor intensities. When a delay of 11 minutes would have applied in these cases, the averaged precipitation intensities reported by the sensor would have been within 1 %. The results of both sensors are very close to each other, except for the cases at 2, 90 and 60 mm/h mentioned above. Applying the second order polynomial and the power law fit and their corresponding corrections only results in error curves that try to compensate for the above-mentioned differences. When the total precipitation sums for each intensity run are compared to the reference then the agreement is within  $\pm 0.5$  % (and even  $\pm 0.2$  % for sensor 1) except at 2 mm/h where the differences are +2 and -6 % for sensor 1 and 2 respectively and at 20 mm/h for sensor 2 where the differences in the sums are -1 %.

Time series of the 1-minute averaged intensities for the Pluvio 250 sensor and the reference are compared in Figure 29. The running 1-minute averaged reference intensity is calculated from the decrease of mass of the reservoir over a running 1-minute period. The 1-minute averaged intensity is reported directly by the sensor. In addition the intensity derived from the corrected collector contents of the Pluvio sensor is also shown. Since the collector content is updated more frequently (every 10-15 seconds at 2 mm/h and every 5 seconds at higher intensities) the curve shows more details and starts reporting precipitation 1 minute before the intensity output. When the sensor updates the 1-minute intensity, it is consistent with the increase in collector content reported by the sensor. The labels on the x-axis indicate 1-minute intervals. The manufacturer reports a delay of up to 7 minutes for intensities below 6 mm/h and 3 minutes at higher intensities. Therefore the runs have been performed such that the data-acquisition has a delay of respectively 8 and 5 minutes before and after each intensity run. That way the previous data is not included and the delays and sums can be verified. Furthermore a delay has been introduced after each change of tubes and after emptying of the collector. At 2 mm/h the start is delayed by 7 minutes whereas the delay is 3 to 4 minutes at higher intensities. The correct intensity is reached with a delay of about 8 minutes at all intensities, therefore the intensity results have been evaluated considering this 8-minute delay. Cessation is delayed by 7 minutes at 2 mm/h, and by 3 minutes for the other intensities. The results for 20 mm/h show the typical behaviour of the sensor. Once the sensor starts reporting precipitation it generally overestimates the intensity in order to compensate for the delay. Since the delay before and after the intensity run are of unequal length, this compensation has to be performed. However, due to this overestimation the reported intensity differs from the actual precipitation intensity, and it is unclear to the user how the reported intensity is related to the actual 1-minute intensity unless the precipitation is constant for at least 9 minutes. Note also that after the end of each intensity run the intensity reported by the sensor remains more or less constant. Only the last 1-minute interval generally reports a lower intensity, which is required in order to get the correct total precipitation

sum. Sensor 198264 showed 6 cases, 4 at 90 and 2 at 660mm/h, where it takes even 11 minutes to reach the correct intensity value. One such case for 90 mm/h is shown in Figure 29. In this situation, as in all other cases with a delay of 11 minutes, the sensor start reporting precipitation rather quickly (only after 2 minutes delay), but the intensity is first underestimated. After 7 minutes the overestimation occurs after which another 4 minutes is required to get the correct intensity. Since the analysis of the results in Appendix 9 and Figure 28 considered the data after a delay of 8 minutes, the overestimation of intensity by the sensor between 8 and 11 minutes is included in the results. The Pluvio results for 20 mm/h show some variability in the sensor results after 8 minutes delay. At higher intensities some variability can still be observed, but its relative contribution decreases fast.

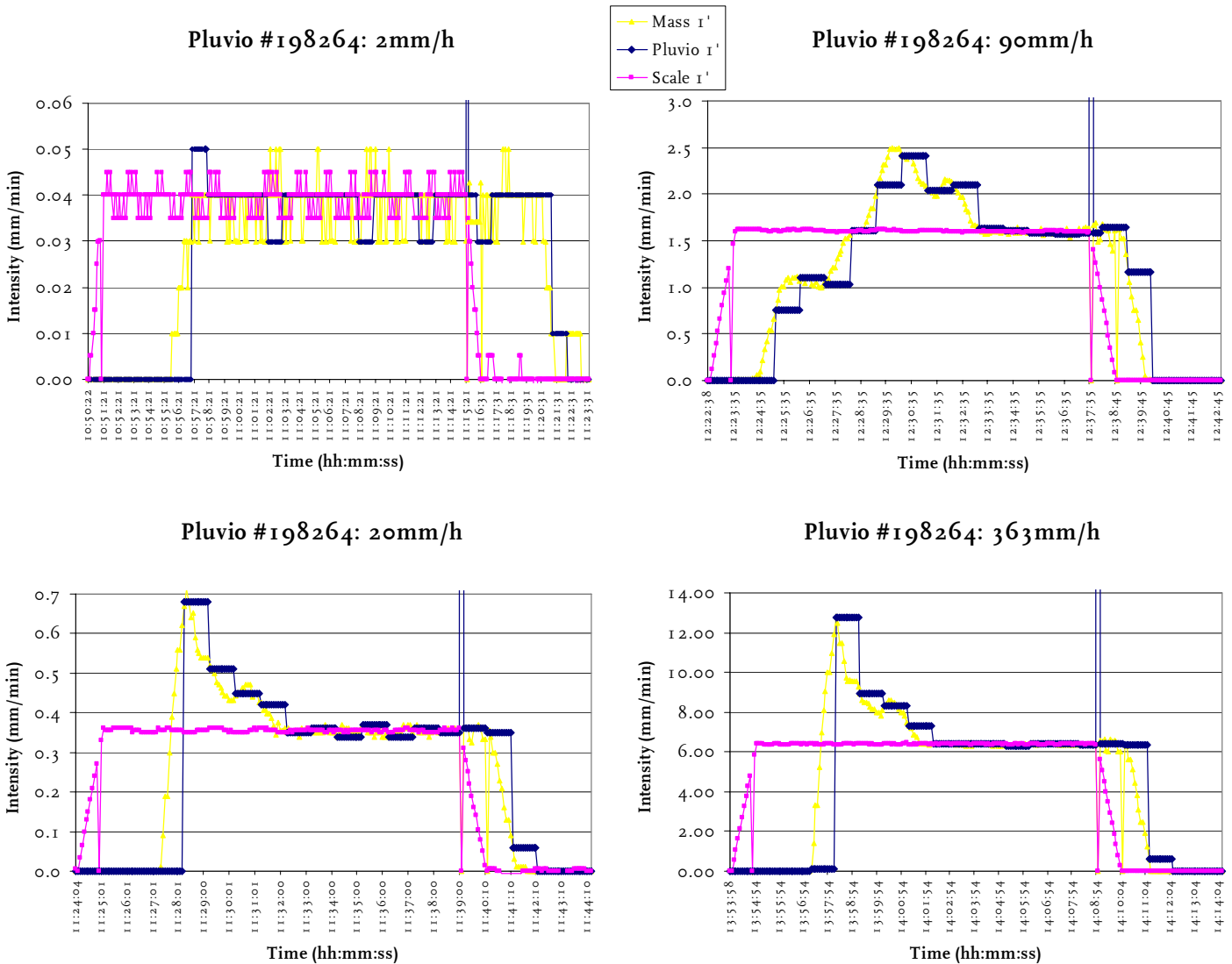

Figure 29: Time series of the running 1-minute averaged reference intensity and the corresponding intensity from the Pluvio 250 measurements of run 4 for instrument 198264.

Comments related to the Pluvio 250 sensor are:

- The tests for this instrument were performed with a sample interval of 5 s.
- The evaporation of the reservoir on the unused scale was measured for intensities up to 363 mm/h and ranged between 0.08 and 0.3 mm/h. This measured evaporation value is compensated in the data analysis. An evaporation of 0.2 mm/h was adopted for intensity levels above 200 mm/h.
- The software version of the Pluvio is 4.0.
- The manufacturer reports a delay of up to 7 minutes for intensities below and 3 minutes at higher intensities. However, the correct intensity is reached after a delay of about 8 minutes at all intensities.
- Sensor 198264 shows 6 cases, 4 at 90 and 2 at 660 mm/h, where it takes 11 minutes to reach the correct intensity value.

### 3.10. India Meteorology Dept. TBRG Mk2

TBRG Mk2

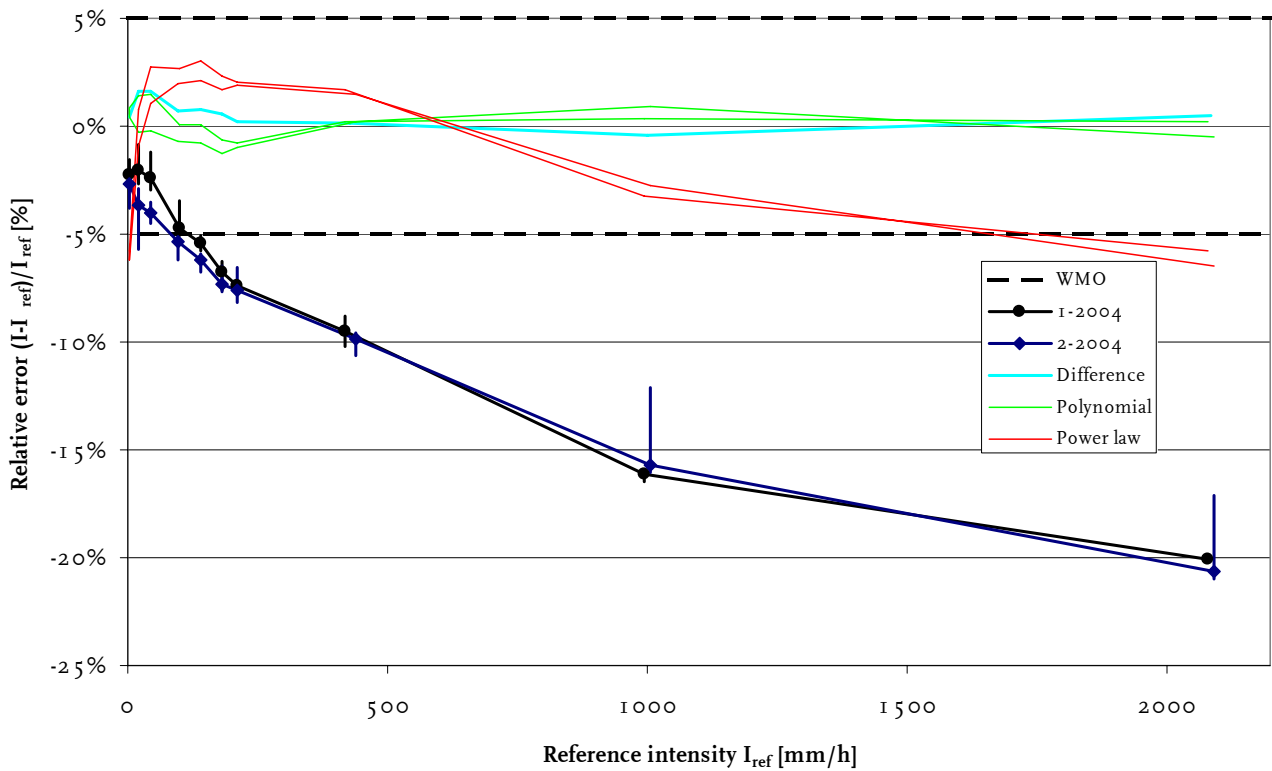

Figure 30: Summary of the test results of the TBRG Mk2 instruments showing the averaged test results of both instruments versus the reference intensity, the relative difference between the results obtained for both instruments, and the errors after a correction using the second order polynomial or power law fit has been applied to the data.

The TBRG Mk2 is a tipping bucket rain gauge with a resolution of 0.5 mm and the collector diameter is 8 in. The instrument has a reed switch output and applies no correction. The manufacturer states an accuracy of  $\pm 3\%$ . The intensity range of the sensor is not mentioned in the sensor sheet.

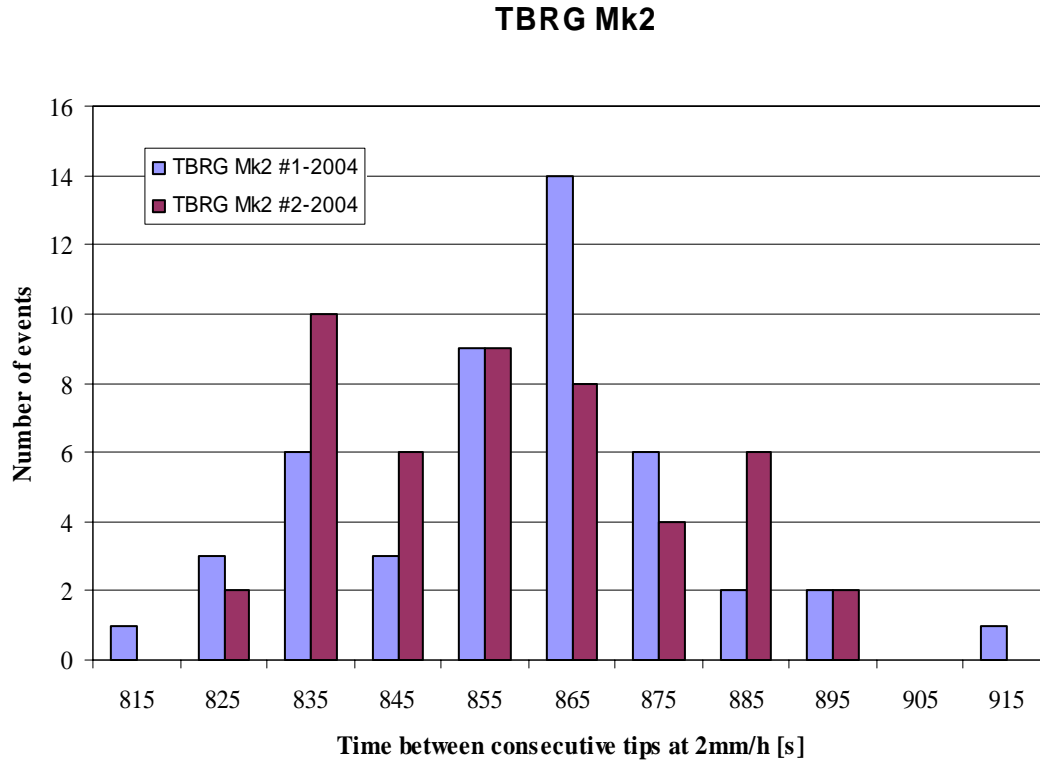

Figure 31: Histogram of the observed time intervals between consecutive tips for both TBRG Mk2 instruments at 2 mm/h. The time denoted at the x-axis is the end time of the time interval, hence 1 tip occurs between 805 and 815 s.

The test results of this sensor are shown in Appendix 10 and are summarized in Figure 30. The results have been obtained by considering the decrease in mass of the reservoir used for the reference intensity and the number of tips reported by the sensor over a period between the first and last tip reported by the sensor. The first 15 s of each intensity run are ignored in order to eliminate startup effects. The averaged results for both instruments are very consistent. Instrument 2 shows more variability in the result at high intensities. The errors of this tipping bucket sensor clearly show the increasing underestimation with increasing precipitation intensity. The differences can be nicely fitted by a second order polynomial and after such a correction the results fall within the limits set by WMO. A correction of the form of a power law fit falls outside the  $\pm 5\%$  limits at 2 and 2000 mm/h. Figure 31 shows the distribution of the time intervals between 2 consecutive tips of the sensor for all 5 test runs at the reference intensity of 2 mm/h for both TBRG Mk2 instruments. The figure shows that the tip intervals for sensor 1 are between 805 and 915 s. Sensor 2 shows a similar distribution without the 2 outliers of sensor 1. The averaged time between consecutive tips is 855 and 852 s for sensors 1 and

2 respectively, which corresponds to intensities of 2.10 and 2.11 mm/h. The standard deviation of the time between consecutive tips is small for both instruments with values of 21 (2) and 19 s (2%), for instruments 1 and 2 respectively.

Comments related to the TBRG Mk2 sensor are:

- The tests for this instrument were performed with a sample interval of 5 s.
- The evaporation was measured using the unused reservoir up to 200 mm/h and taken into account in the reference intensity. Evaporation ranged between 0.04 and 0.12 mm/h. An evaporation of 0.08 mm/h was adopted for intensities above 200 mm/h.
- The fact sheet does not specify the maximum intensity, but tests showed that the sensor can handle intensities up to 2000 mm/h without accumulation of water in the funnel.
- The characteristics of the reed contact are not reported in the fact sheet. The mono-step was operated using  $R = 6.56 \text{ M}\Omega$ , i.e. a time constant of 0.65 s.
- Both TBRG Mk2 instruments have been aligned using the spirit level. The rim of sensor 1 deviated by about 5 mm from the horizontal position, whereas the rim of sensor 2 was nearly horizontal (deviation of only 1 mm).
- The sensor cover of sensor 1 fitted very tightly around the base and could only be removed with difficulty, whereas the hood of sensor 2 fitted nicely.
- The tipping balance is fixed with 4 bolts to the base. In sensor 1 all 4 nuts were missing on these bolts whereas for sensor 2 only 1 nut was missing.
- The clamps for fastening the sensor to the ground are aligned differently for instrument 1 and 2. The differences are about 1 cm.
- The sensors were delivered with only 1 debris protection filter. The filter, which covers the full width of the funnel, was not used in these tests.
- The sensor gives a lot of spatter underneath the balance of the sensor, but the balance itself is internally not very much affected by spatter even at 2000 mm/h. The spatter is caused when the water in the tipping bucket is released after a tip and hits the sensor cover.
- The base of the sensor contains 2 large holes through which water can escape after a tip. Since the holes are not covered by a gauze insects can easily enter the sensor.

### **3.11. SIAP UM7525**

The UM7525 is a tipping bucket rain gauge with a resolution of 0.2 mm and the collector area is 1000 cm<sup>2</sup>. The instrument has a reed switch output. During the tilting of the tipping balance a sphere prevents water in the collecting funnel from flowing into the tipping bucket. This interruption of the flow should prevent the loss of precipitation during the tip. The sensor is delivered with a logger that reports the number of tips observed in each 1-minute interval. The logger requires a start-up of 1 hour and does not handle the transition from one hour to the next properly. Hence the logger was not used in this test. The manufacturer states an accuracy of  $\pm 0.1$  mm for rain rates below 5 mm/h and  $\pm 2\%$  for rain rates above 5 mm/h. The intensity range of the sensor is higher than 250 mm/h. Tests showed that the sensor was able to measure intensities up to 300 mm/h. At higher intensities water accumulates in the funnel.

## UM7525

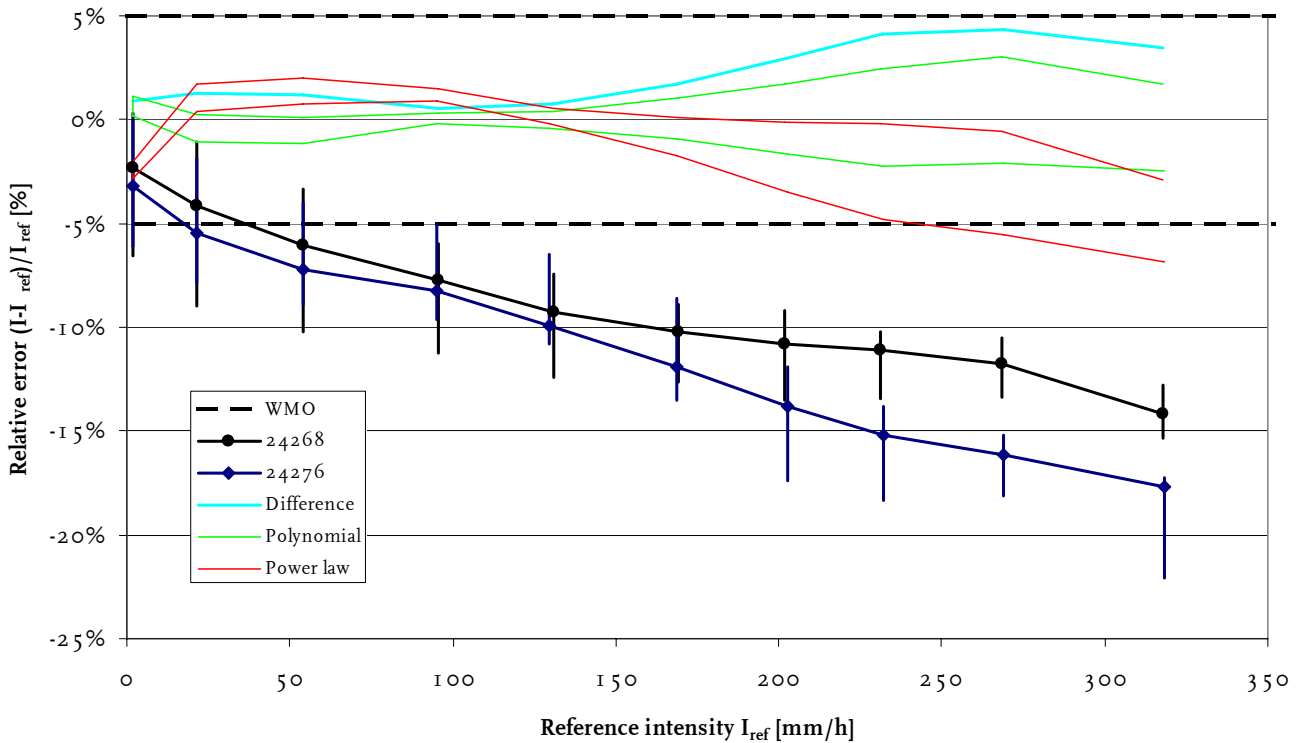

Figure 32: Summary of the test results of the UM7525 instruments showing the averaged test results of both instruments versus the reference intensity, the relative difference between the results obtained for both instruments, and the errors after a correction using the second order polynomial or power law fit has been applied to the data.

The test results of this sensor are shown in Appendix 11 and are summarized in Figure 32. The results have been obtained by considering the decrease in mass of the reservoir used for the reference intensity and the number of tips reported by the sensor over a period between the first and last tip reported by the sensor. The first 15 s of each intensity run are ignored in order to eliminate startup effects. Both instruments underestimate the intensity, and the relative differences increase with increasing reference intensity up to about  $-15\%$ . Clearly, the mechanical correction with the sphere that should prevent loss of water during a tip does not eliminate the underestimation of the tipping bucket sensors. The results are not within the limits of  $\pm 5\%$  for most of the intensity range. The averaged results for both instruments differ by about  $2\%$  up to  $170\text{ mm/h}$ , but at higher intensities the differences increase up to  $4\%$ . Sensor 1 gives higher intensity values than sensor 2 over the entire intensity range. The differences for this sensor can be nicely fitted by a second order polynomial and after a correction by this polynomial the results fall within the limits set by WMO. A correction of the form of a power law fit falls outside the  $\pm 5\%$  limits for sensor 2 for intensities above  $230\text{ mm/h}$ .

## UM7525

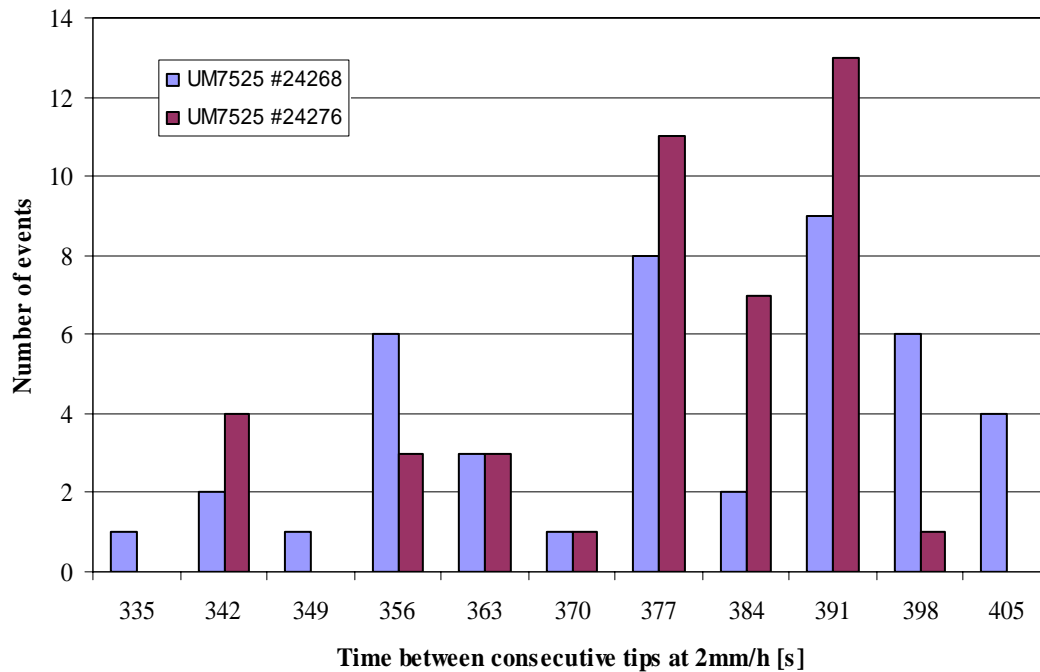

Figure 33: Histogram of the observed time intervals between consecutive tips for both UM7525 instruments at 2 mm/h. The time denoted at the x-axis is the end time of the time interval, hence 1 tip occurs between 328 and 335 s.

Figure 33 shows the distribution of the time intervals between 2 consecutive tips of the sensor for all 5 test runs at the reference intensity of 2 mm/h for both UM7525 instruments. The figure shows that the tip intervals for sensor 1 are between 328 and 405 s. Sensor 2 shows a similar distribution without the 2 outliers of sensor 1. The averaged time between consecutive tips is 375 and 374 s for sensors 1 and 2 respectively, which corresponds to intensities of 1.91 and 1.92 mm/h. The standard deviation of the time between consecutive tips is 19 (5) and 15 s (4%) for instruments 1 and 2, respectively.

Comments related to the UM7525 sensor are:

- The tests for this instrument were performed with a sample interval of 5 s.
- The evaporation was measured using the unused reservoir up to 90 mm/h and taken into account in the reference intensity. Evaporation ranged between 0.01 and 0.03 mm/h. An evaporation of 0.03 mm/h was adopted for intensities above 90 mm/h.
- The serial number of the sensor is only given on the sensor cover and not on the base of the sensor itself.
- The logger provided with the sensor was not suitable for the purpose of this test and was omitted.

- The manufacturer reports the intensity range as  $> 200$  mm/h. Tests showed that the range is 0-300 mm/h.

### 3.12. CAE PMB2

The PMB2 is a tipping bucket rain gauge with a resolution of 0.2 mm and the collector area is  $1000 \text{ cm}^2 \pm 0.5 \%$ . The instrument has a reed switch output. The sensor comes with a data logger that acquires the tips with a millisecond time resolution. The data logger shows the raw precipitation sum that is directly related to the number of pulses, furthermore the intensity and maximum intensity is displayed. The data logger can be read by an application that is supplied by the manufacturer and reports on 1-minute intervals the raw precipitation sum as well as the corrected intensity. The 1-minute averaged intensity is calculated with a 1-minute delay, because a tip in the next interval is required to determine the intensity in the previous interval. The intensity threshold therefore is 1 tip per minute and hence  $60 \times 0.2 = 12$  mm/h. The usage of the data logger was considered, but the data is only available on a 1-minute resolution and the time synchronisation between the logger and the acquisition PC is required. Since the data logger has no real added value (except the internal time stamping on millisecond resolution) it was decided not to use the logger and to connect the sensor via the mono-step to the counter. The correction formula is applied to the data afterwards. The manufacturer states that the accuracy after correction of the systematic error is  $\pm 1 \%$  below 60 mm/h,  $\pm 2 \%$  between 60 and 200 mm/h and  $\pm 4 \%$  above 200 mm/h. The reported repeatability is  $\pm 0.25$  mm/h at 60 mm/h and the interchangeability is  $\pm 1$  mm/h at 60 mm/h. The intensity range of the sensor is 0-300 mm/h.

The test results of this sensor are shown in Appendix 12 and are summarized in the upper panel of Figure 34. The results have been obtained by considering the decrease in mass of the reservoir used for the reference intensity and the number of tips reported by the sensor over a period between the first and last tip reported by the sensor. The first 15 s of each intensity run are ignored in order to eliminate startup effects. The number of tips over a specific time interval is converted into intensity. The corrected intensity  $I_c$  is calculated from the measured intensity  $I$  using the relation  $I_c = 1/(1/I - 0.00062)$ . Figure 34 shows that the correction places the results of both instruments within the  $\pm 5 \%$  limits set by WMO. At intensities below 150 mm/h the results are within  $\pm 1 \%$  of the reference, however, at higher intensities the instruments overestimate the precipitation intensity up to  $+4 \%$ . The applied correction seems too large. The results of both instruments show good agreement. Sensor 1 gives intensities, which are 1 % lower than sensor 2 over the entire intensity range. The differences for this sensor can be fitted by a second order polynomial, which removes the intensity dependence of the results. This is not taken care of by the power law fit. The uncorrected PMB2 results are given in the lower panel of Figure 34 and are summarized in a table in Appendix 12. As could be expected, both instruments show again good agreement. The raw sensor data show the well-known underestimation of the tipping bucket rain gauges. These errors can be nicely fitted by a second order polynomial and after correction with this polynomial the errors are almost the same as for the corrected sensor results in the upper panel. A correction with a

polynomial fit gives similar results as for the corrected sensor data, but the sign of the remaining errors is inverted.

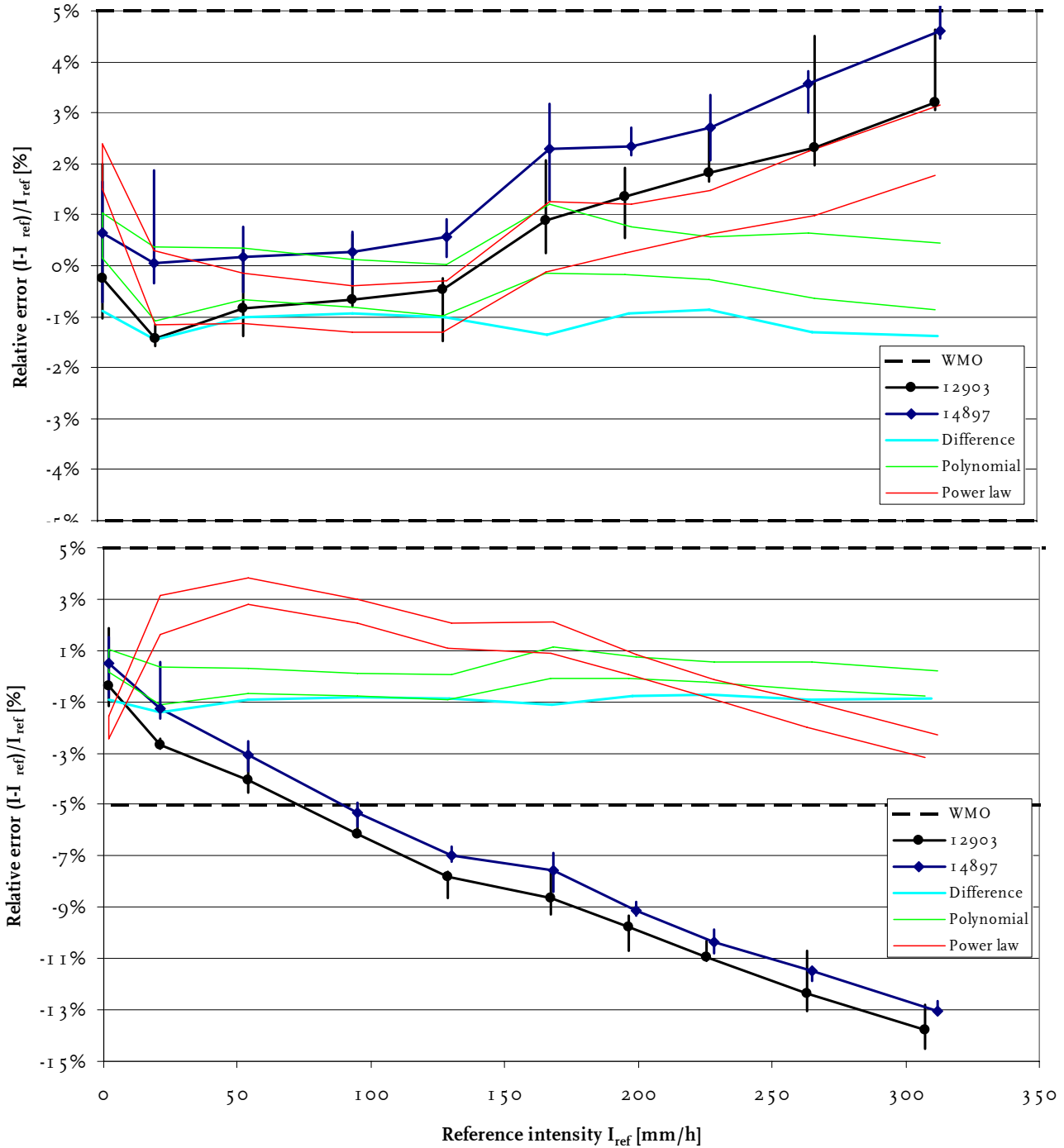

Figure 34: Summary of the test results of the PMB2 instruments showing the averaged test results of both instruments versus the reference intensity, the relative difference between the results obtained for both instruments, and the errors after a correction using the second order polynomial or power law fit has been applied to the data. The top panel shows the corrected results the bottom panel the results from the raw tips of the sensor.

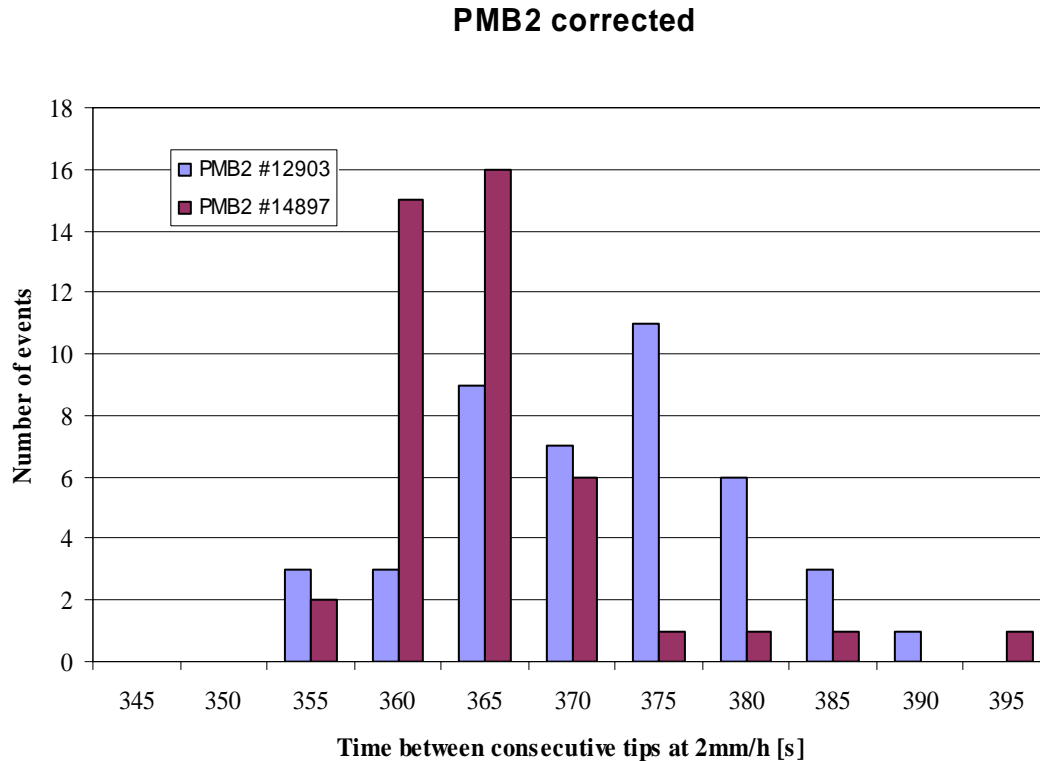

Figure 35: Histogram of the observed time intervals between consecutive tips for both PMB2 instruments at 2 mm/h. The time denoted at the x-axis is the end time of the time interval, hence 1 tip occurs between 328 and 335 s.

Figure 35 shows the distribution of the time intervals between 2 consecutive tips of the sensor for all 5 test runs at the reference intensity of 2 mm/h for both PMB2 instruments. The relation for the corrected intensity given above can be rewritten into the relation  $\Delta tip_c = \Delta tip - 0.00062 \times 3600 \times 0.2$  for the corrected time between consecutive tips  $\Delta tip_c$  in seconds by using the relation given in section 2.5 that expresses the intensity in terms of the time interval between consecutive tips  $\Delta tip$  and the resolution of the tipping bucket. Hence the applied correction is equivalent to the shortening of the time between consecutive tips by a fixed amount. This correction has been applied individually to all the tips. Figure 35 shows that the distribution of the times between consecutive tips is broader for sensor 1. The averaged time between consecutive tips is 371 and 365 s for sensors 1 and 2 respectively, which corresponds to intensities of 1.94 and 1.97 mm/h. The standard deviation of the time between consecutive tips is 8.5 (2) and 7.5 s (2 %) for sensors 1 and 2, respectively.

Comments related to the PMB2 sensor are:

- The tests for this instrument were performed with a sample interval of 5 s.

- The evaporation was measured using the unused reservoir up to 90 mm/h and taken into account in the reference intensity. Evaporation ranged between 0.01 and 0.04 mm/h. An evaporation of 0.03 mm/h was adopted for intensities above 90 mm/h.
- The intensity threshold of 0.2 mm per 1 minute corresponding to 12mm/h applies to all tipping buckets, but the PMB2 is the only sensor where this limitation of a tipping bucket is explicitly mentioned. The threshold is also evident in the intensity values reported by the data logger.
- During testing the data logger at one instance reacted strangely. It reported a precipitation amount, but the intensity as well as the maximum intensity remained zero even at intensities well above 12mm/h. Restarting the sensor and data logger did not overcome this problem. The next day the system worked again.
- The collector surface of this sensor is rather raw and after spatter many droplets remain in the collector.
- The top of the partitioning wall between the 2 tipping buckets is broad and round and causes a lot of spatter inside the sensor

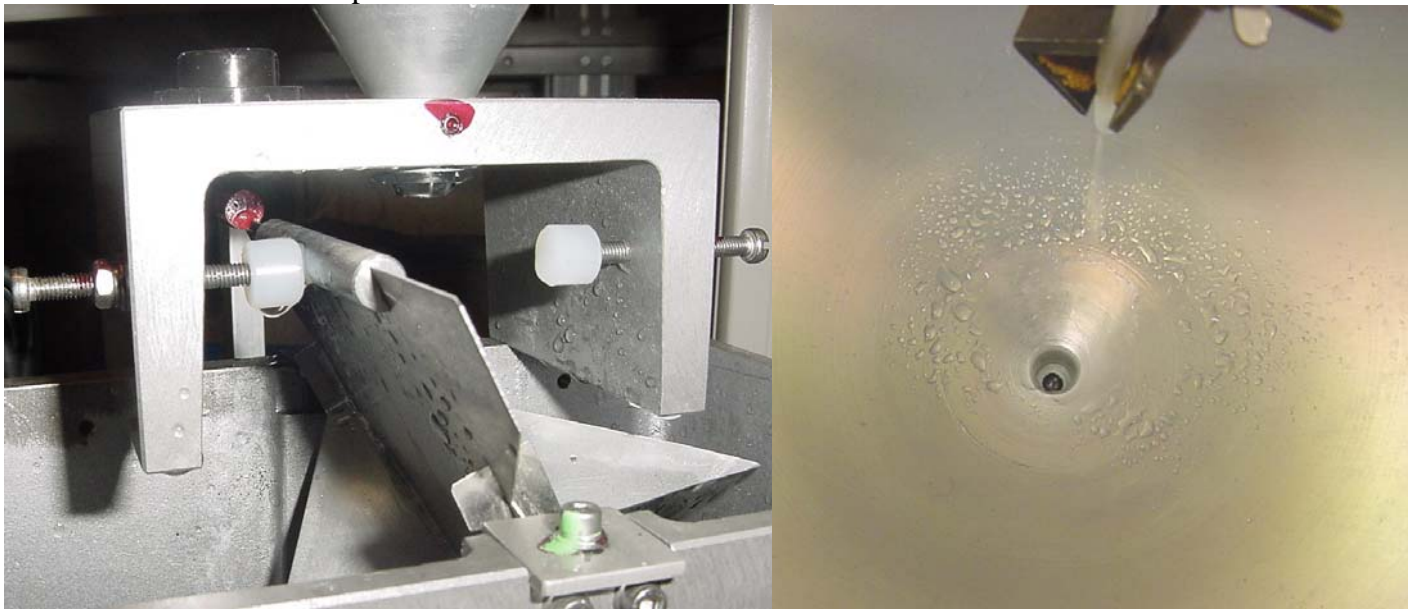

Figure 36: Photographs of the PMB2 sensor showing the partitioning wall between the 2 tipping buckets with spatter and the spatter in the collector.

### **3.13. ETG R102**

The R102 is a tipping bucket rain gauge with a resolution of 0.2 mm and the collector area is  $1000 \text{ cm}^2 \pm 0.5 \%$ . The sensor comes with an acquisition system that acquires the reed contacts and applies a correction to overcome the well-known underestimation of tipping bucket rain gauges at higher intensities. The acquisition system reports an output string every 30 seconds. The string gives the accumulated precipitation sum in steps of 0.2 mm and the precipitation intensity in 0.01 mm/min. When ever the system thinks that the underestimation reached 0.2 mm an additional amount of 0.2 mm is added to the reported precipitation amount. The manufacturer states that the accuracy is within  $\pm 5 \%$  over the entire intensity range from 0-300 mm/h.

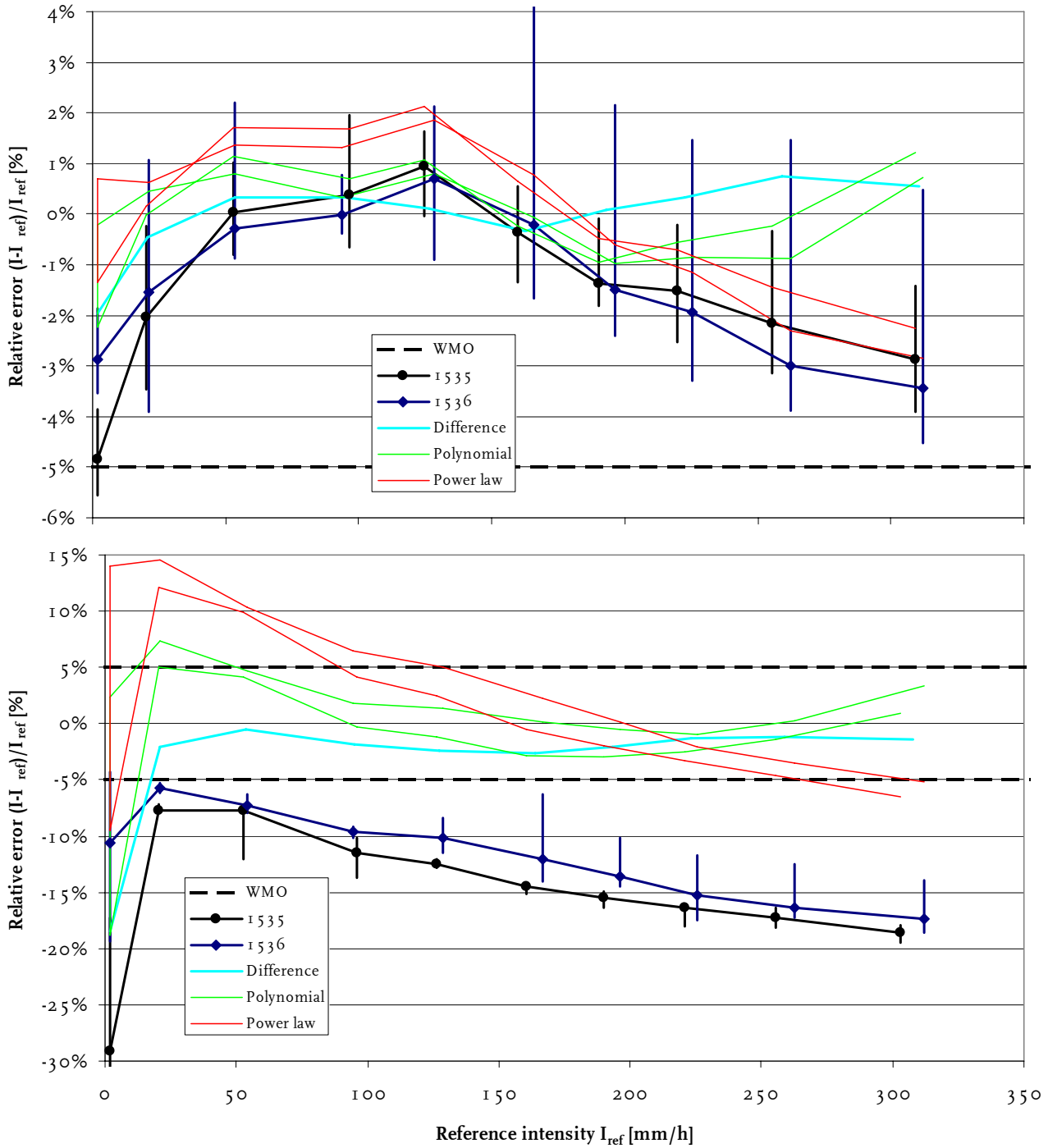

Figure 37: Summary of the test results of the R102 instruments showing the averaged test results of both instruments versus the reference intensity, the relative difference between the results obtained for both instruments, and the errors after a correction using the second order polynomial or power law fit has been applied to the data. The top panel shows the results obtained from the “tips”, the bottom panel shows the results for the intensities.

The test results of this sensor are shown in Appendix 13 and are summarized in Figure 37. The intensity reported by the sensor is averaged over the period of the test, but the first minute is ignored in order to filter out start-up effects and the period is further restricted to the interval between the first and last reported increment. The intensity is also derived from the “tips”, i.e. the 0.2 mm increments in the precipitation accumulation, where the period is again restricted between the first up to the last reported increment. In both cases the reference intensity is calculated from the decrease in mass of the scales over the same time interval. A correction for evaporation is applied. The upper panel of Figure 37 shows that the results obtained from the “tips” are within the  $\pm 5\%$  limits set by WMO. The results of both instruments show good agreement and are within  $\pm 1\%$  of each other except at 2 mm/h. Both instruments show the same behavior, i.e. the error curves have an inverted “U” shape with underestimations of about  $-4\%$  at 2 and 300 mm/h and an overestimation of about  $+1\%$  at 130 mm/h. The corrections using the second order polynomial and the power law fit reduce the error. Again the correction by the polynomial fit gives better results than the power law fit with respect to magnitude and suppression of the inverted “U” shape of the error curves. The lower panel of Figure 37 shows the error curves obtained from the intensity values reported by the R102 sensor. The intensity results differ from the results derived from the accumulation increments. The intensity results always give an underestimation and strongly depend on the intensity. It almost seems that the intensity results of the sensor are uncorrected. The behavior of the error curves is rather smooth, except for the large underestimation at 2 mm/h. The results of both instruments are again very close, except at 2 mm/h. Unlike the results for the accumulation increments, sensor 1 gives lower values than sensor 2 at all intensities. Due to the peak and the large discrepancies between the 2 instruments at 2 mm/h the polynomial corrections cannot put the error curves within the  $\pm 5\%$  limits at low intensities and shows an intensity dependency.

Figure 38 shows the distribution of the time intervals between 2 consecutive increments of the accumulated precipitation reported for all 5 test runs at the reference intensity of 2 mm/h for both R102 instruments. The 30-second update time of the sensor is reflected in the three groups of events at 400, 430 and 460 s. Timing issues between the sensor and the data-acquisition PC causes the splitting of each 3-second group over 2 10-minute intervals. It is clear from the figure that sensor 1 shows more variation and larger time intervals, although the supplied reference intensity for sensor 1 and 2 are nearly identical and was more stable for sensor 1. The averaged time between consecutive tips is 411 and 394 s for sensors 1 and 2 respectively, which corresponds to intensities of 1.75 and 1.83 mm/h. The standard deviation of the time between consecutive tips is 17 (4) and 10 s (3 %) for sensors 1 and 2, respectively.

## R102

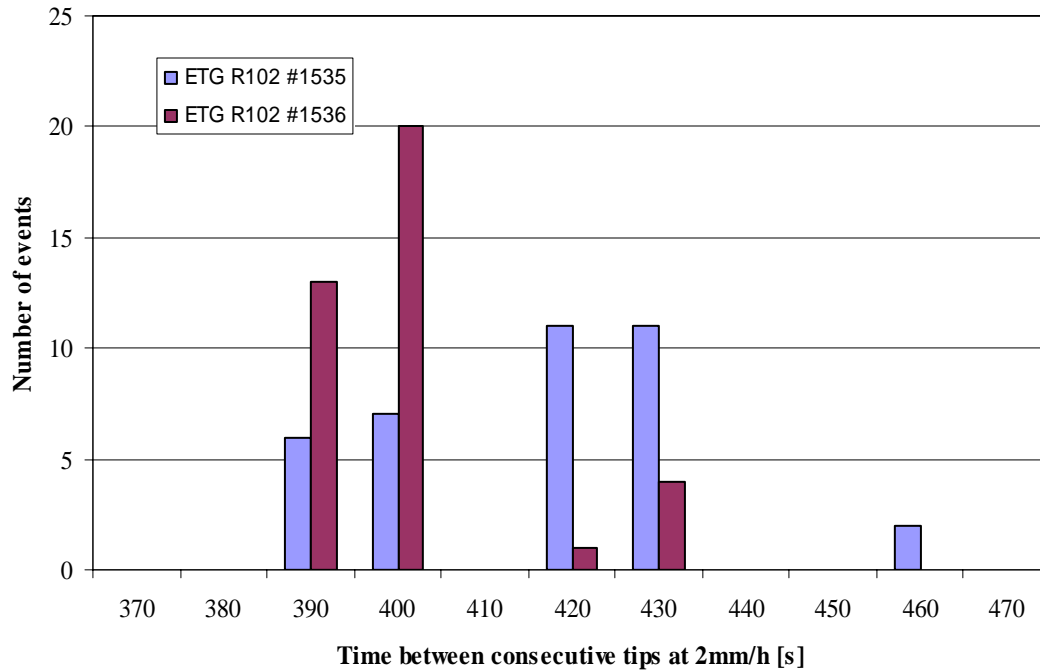

Figure 38: Histogram of the observed time intervals between consecutive tips for both PMB2 instruments at 2 mm/h. The time denoted at the x-axis is the end time of the time interval, hence 1 tip occurs between 328 and 335 s.

Time series of the 1-minute averaged intensities reported every 30-seconds by the R102 sensor and the running 1-minute averaged reference intensity are compared in Figure 39. The intensity reported by the sensor does not change when no precipitation is detected; hence the sensor keeps reporting the last measured intensity after cessation of a precipitation event or a test run. When one tip is detected the sensor immediately reports an intensity of 0.02 mm/min, which corresponds with the threshold of 1.2 mm/h that can be observed for the runs at 2 mm/h. A second tip is needed within a certain time interval in order to derive a correct intensity. This time interval is not specified in the documentation. The resolution of the reported intensity is 0.01 mm/min, i.e. 0.6 mm/h. The time series at 2 and 2 mm/h show the variability resulting from the resolution of the sensor. However, even at higher intensity levels variability can be observed in the reported intensity. It seems that the resolution of the reported intensity decreases with intensity. Some variability could be expected because of the additional increments that are inserted by the sensor whenever 0.2 mm is added to compensate for the underestimation of the tipping bucket sensor, but its relative contribution should diminish at higher intensities. The time series clearly show the underestimation of the intensity by the R102 sensor. The delay at low intensities results mainly from the time required for 2 tips to occur, whereas the delay at higher intensities is caused by the 30-second update time of the sensor.

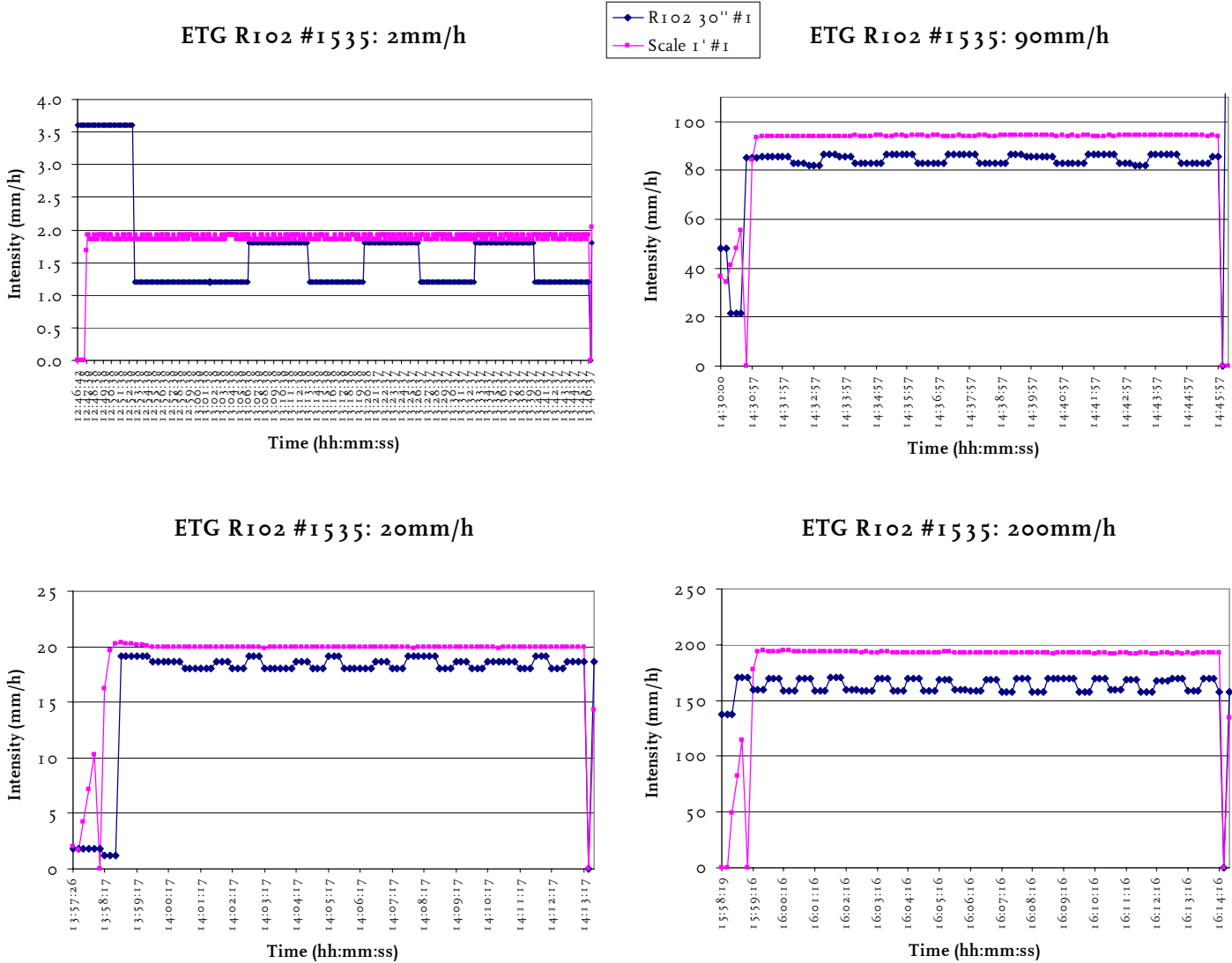

Figure 39: Time series of the running 1-minute averaged reference intensity and the 30-second intensity from the R102 measurements of run 1 for instrument 1535.

Comments related to the R102 sensor are:

- The tests for this instrument were performed with a sample interval of 10 s.
- The evaporation was measured using the unused reservoir up to 90 mm/h and taken into account in the reference intensity. Evaporation ranged between 0.01 and 0.04 mm/h. An evaporation of 0.02 mm/h was adopted for intensities above 90 mm/h.
- The rim of the orifice is not sharp and with a slope outwards.
- The rim is not exactly circular and shows dents and contains burrs.
- The sensor has a 30-second update period. This is configurable but the documentation does not specify how.
- The software version of the sensor is not reported in the manual nor is it given by the sensor interface.

- The partitioning wall of the tipping element has a rather broad (5mm) and flat upper surface that causes spatter during a tipping event.
- After a tipping event the tipping element lowers into a compartment containing the released water so that droplets remain attached to the bottom of the element.
- A small amount of water gathers in a rim between the collector and the entry to the inner funnel.
- For one instrument the inner tube that leads water from the outer to the inner funnel was loose and fixed before performing the test runs.
- The precipitation intensity reported by the sensor shows large differences and is not consistent with the reported precipitation accumulation.
- After a precipitation event the reported precipitation intensity is maintained constant until a new tip occurs (this may take days!!) at which the reported intensity is 0.02mm/min.
- A second tip is required in order to derive a correct intensity from the time interval between the 2 tips. The manufacturer does not specify the maximum time interval allowed for calculating the intensity. Neither are available any other details of the intensity calculation.
- The tipping bucket was not fixed during transport.
- The wiring of the pulse output of both instruments is reversed.

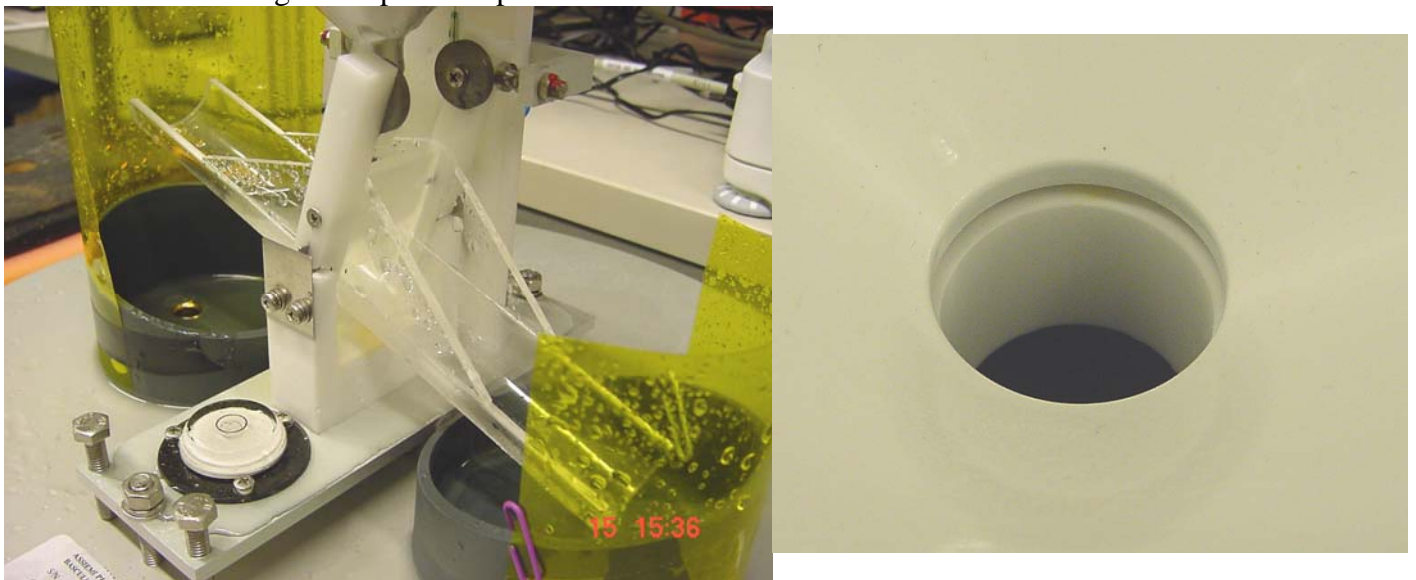

Figure 40: Photographs of the R102 sensor showing the tipping balance with spatter and the rim between the in the collector and the entry to the inner funnel.

### **3.14. Yokogawa Denshi Kiki Co. WMB01**

The WMB01 is a tipping bucket rain gauge with a resolution of 1 mm and the collector area is 314.2 cm<sup>2</sup>. The sensor is equipped with electronics and a serial output that reports the intensity with a resolution of 0.1 mm/h. The sensor software applies corrections. More details of the sensor are not available. An intensity range of 0-200 mm/h was adopted during the tests at KNMI. A single test run was performed up to 400 mm/h showing that the sensor performed well. Météo France considered a range up to

2000 mm/h and their tests showed that the sensor works fine over the entire range. Later we were informed that the sensor was developed to cover the range up to 2000 mm/h specifically for this WMO test.

WMB01

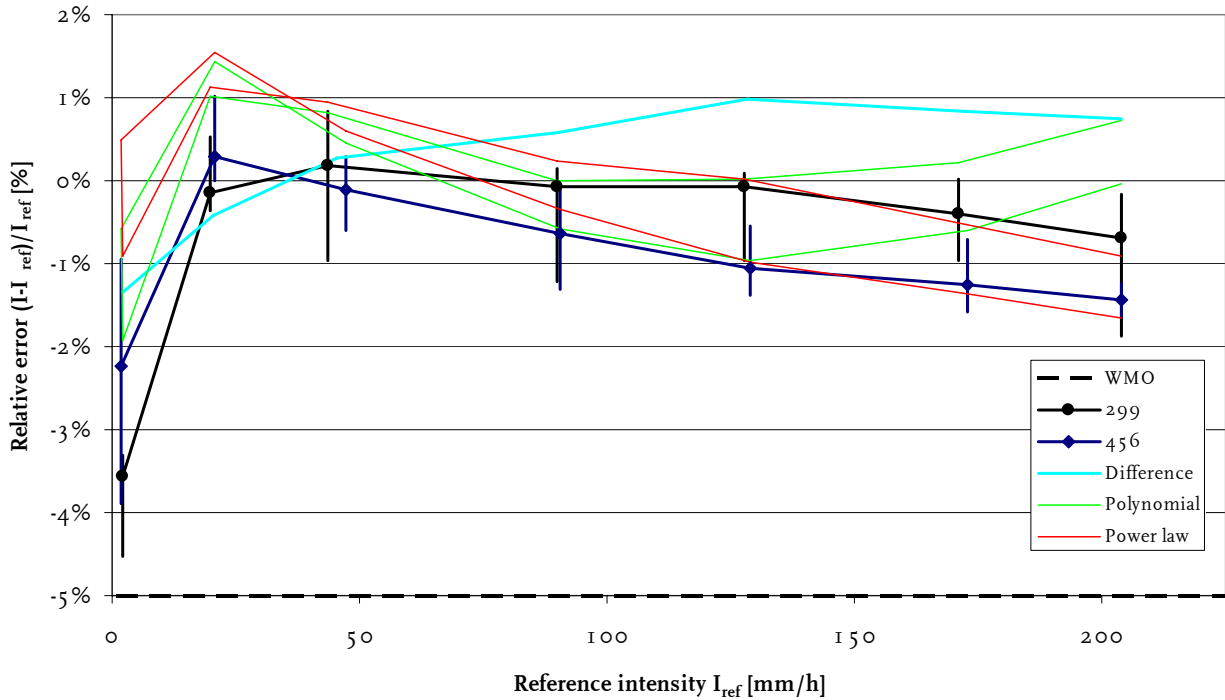

Figure 41: Summary of the test results of the WMB01 instruments showing the averaged test results of both instruments versus the reference intensity, the relative difference between the results obtained for both instruments, and the errors after a correction using the second order polynomial or power law fit has been applied to the data.

The test results of this sensor are shown in Appendix 14 and are summarized in Figure 41. The intensity reported by the sensor is averaged over the period of the test, but the time interval before the first 2 tips is ignored. Since the sensor has a resolution of 1 mm the delay at 2 mm/h was up to 1 hour. The reference intensity is calculated from the decrease in mass of the scale over the same time interval. The evaporation rate was not measured during the test. An estimated evaporation rate of 0.1 mm/h was adopted. Figure 41 shows that both WMB01 instruments underestimate precipitation at 2 mm/h. An evaporation rate of 0.15 mm/h would be required to overcome this problem, but such a rate was considered too large. The intensity reported by the sensor shows good agreement with the reference and is within the  $\pm 5\%$  limits set by WMO. Both instruments agree within  $\pm 1\%$  of each other except at 2 mm/h. The second order polynomial and the power law corrections reposition the error curves around zero, but they cannot compensate for the large deviations at 2 mm/h.

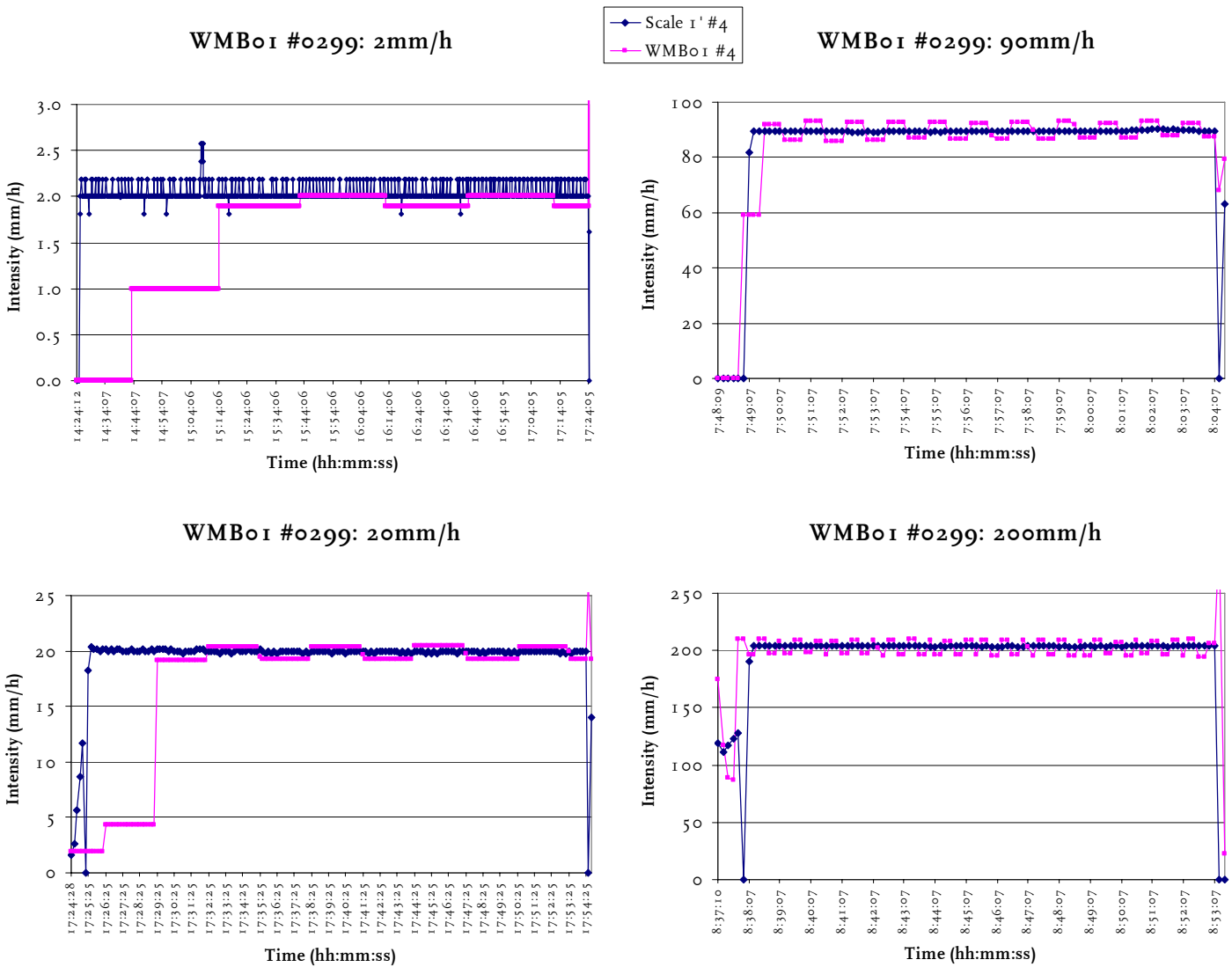

Figure 42: Time series of the running 1-minute averaged reference intensity and the intensity reported by the WMB01299 sensor during run 1. The vertical labels denote 1-minute intervals, except at 2 mm/h where 10-minute intervals are indicated.

Time series of the intensities reported by the WMB01 sensor and the running 1-minute averaged reference intensity are compared in Figure 42. The time series clearly show the delay of 2 tip events. The delay is, as expected, nearly 1 hour at 2 mm/h and the intensity run is restricted to 3 hours so that only 5 tips are used for this test. It seems like the sensor starts reporting 1 mm/h after 1 tip and only at the second tip the correct intensity can be calculated. During the test runs no delays were inserted in order to let the sensor return to 0 mm/h before starting the next intensity run. This would require delays of at least 1 hour between each run since the sensor reports an intensity of 1 mm/h up to 1 hour after the end of an intensity run. The time series at all intensities show variations of the intensities reported by the sensor around the reference intensity. The variations do not reduce with

increasing intensity. This is probably caused by the intensity calculation in combination with the correction that is applied in the sensor software. Details on sensor software are not available.

Comments related to the WMB01 sensor are:

- The tests for this instrument were performed with a sample interval of 10 s.
- The evaporation rate was not measured for this sensor. Comparison of the ambient conditions with those observed during the tests of other sensors resulted in an estimated evaporation rate of 0.1 mm/h. Application of this correction reduced the underestimation at 2 mm/h by about 5 %.

### **3.15. Geonor T-200B**

The T-200B is a weighing rain gauge with a collector area of 200 cm<sup>2</sup>. The precipitation is collected in a 12-l bucket so that the capacity of the sensor is 600 mm before manual emptying is required. A precision load cell with a vibrating wire determines the weight of the bucket, which is suspended from 2 chains and 1 load cell. Hence the load cell measures only  $\frac{1}{3}$  of the weight of the bucket when the sensor is properly aligned. The sensor was delivered with an analog interface gives the vibration frequency  $f$ , which range between 1000 and 3000 Hz for an empty and full bucket, respectively. The precipitation amount  $P$  (in cm) accumulated in the buckets can be calculated from the expression  $P = A \times (f - f_0) + B \times (f - f_0)^2$ , where  $A$  and  $B$  are transducer calibration constants and  $f_0$  is the transducer frequency for an empty bucket. The three calibration coefficients were specified on the calibration certificate provided by the manufacturer for each instrument. The accuracy reported by the manufacturer is 0.1 % full scale. The reported sensitivity and reproducibility of the T-200B sensor is 0.1 mm. The resolution of the transducer is better than 0.01 % full scale. Hence a value of 0.01 mm is adopted for the resolution. The intensity range of the sensor specified by the manufacturer is 0-600 mm/h.

The test results of this sensor are shown in Appendix 15 and are summarized in Figure 43. The frequency reported by the sensor converted to precipitation amount and its increase over the period of the test, ignoring the first 30-seconds in order to account for start-up effects, gives the sensor intensity. The reference intensity is calculated from the decrease in mass of the reservoir on a scale over the same time interval. The evaporation rate was not measured during the test. An estimated evaporation rate of 0.16 mm/h was adopted. Figure 43 shows that both T-200B instruments underestimate the intensity over the entire intensity range. However, the underestimation is small, i.e. -2 and -1 % for instrument 1 and 2 respectively, and constant. Below 100 mm/h the errors show more variation and larger values, especially for sensor 1 with an error up to nearly -5 % at 50 mm/h. The differences between both instruments show the same behaviour. The sensor shows good agreement with the reference and is within the  $\pm 5$  % limits set by WMO. The effect of using only 2 raw sensor readings that might be affected by vibrations versus all 10-second readings in order to determine the averaged intensity over the time interval is shown by the solid and dotted lines. Some differences in the error curves can be observed, particularly below 200 mm/h, but the results are almost the same. The second order polynomial and the power law corrections correct for the sensor offset, but because

of the smoothness of the fitted functions they cannot compensate for the variations below 100 mm/h.

T-200B

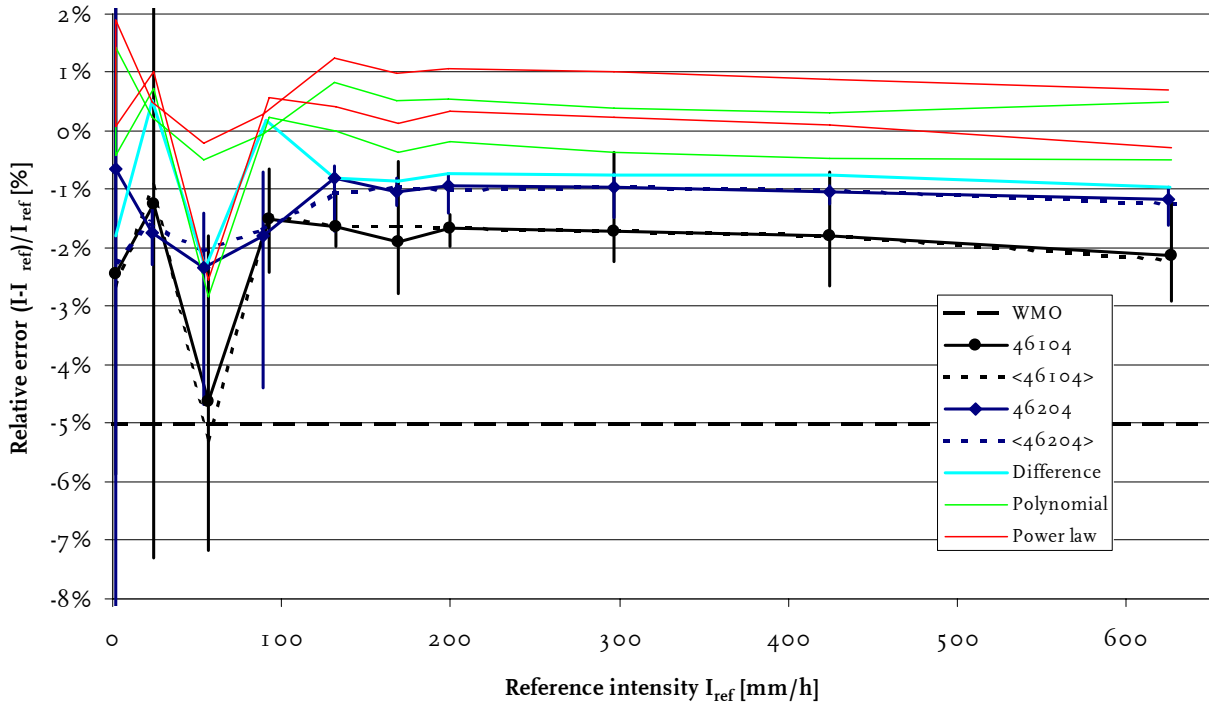

Figure 43: Summary of the test results of the T-200B instruments showing the averaged test results of both instruments versus the reference intensity, the relative difference between the results obtained for both instruments, and the errors after a correction using the second order polynomial or power law fit has been applied to the data. The sensor results are obtained from the reported difference in accumulated precipitation amount over at time interval of the test (solid lines) as well as by averaging the running 1-minute intensities obtained every 10 seconds from the increase in accumulated precipitation over the previous minute (dashed lines).

Time series of the running 1-minute averaged intensities derived from the T-200B sensor and reference are shown in Figure 44. The time series clearly show the variability of the T-200B sensor, especially at low intensities. It should be noted that cases with higher as well as lower variability were also observed. The variability is also evident at 20 mm/h, but it is not present at 50 mm/h and at higher intensities, although at these intensities smooth fluctuations can occur. Note that the sensor reports the accumulated precipitation amount nearly instantaneously. Therefore vibrations, e.g. introduced by the impact of the precipitation droplets themselves, might affect a 10-second reading of the sensor. The results in the time series are averages of 6 reading, but they show almost the same variability as the intensity derived per 10-second interval. The time series at 20 and 50

mm/h show situations where the sensor underestimates the intensity. At 50 mm/h the sensor continuously underestimates the intensity except at the very end of the run. The time series also show that the delay of the sensor is small. The intensity is the sensor gives the correct value within 20 seconds.

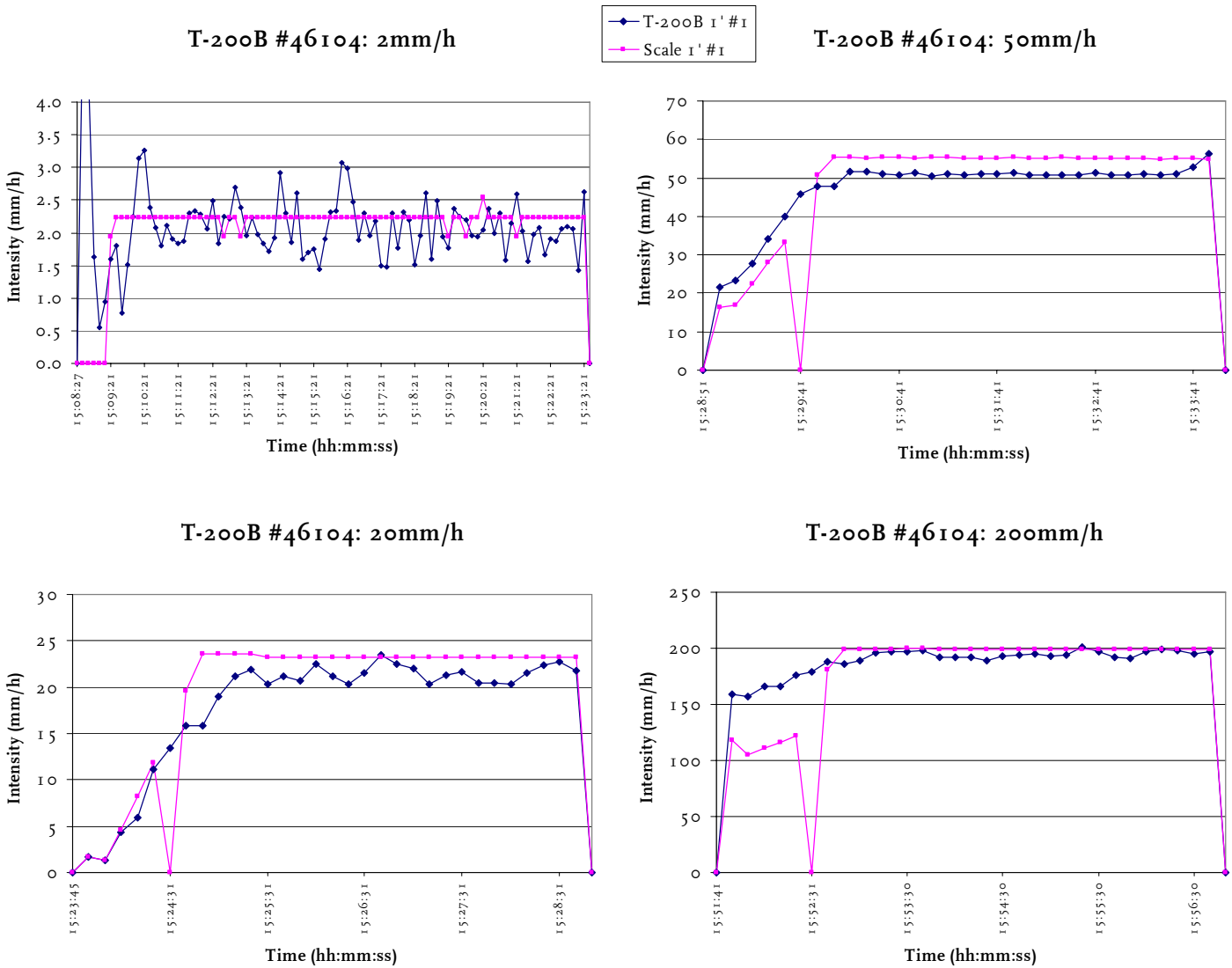

Figure 44: Time series of the running 1-minute averaged intensities of the reference and the T-200B 46104 sensor during run 1. The vertical labels denote 1-minute intervals.

Comments related to the T-200B sensor are:

- The tests for this instrument were performed with a sample interval of 10 s.
- The evaporation rate was not measured for this sensor. Comparison of the ambient conditions with those observed during the tests of other sensors resulted in an estimated evaporation rate of 0.16 mm/h.
- The sensor does not use a funnel, but precipitation falls directly into the bucket whose weight is measured continuously. However, precipitation has to fall about 18 cm from

the orifice of the collector to that of the bucket during which it may attach to the inner cylindrical surface of the collector.

- When re-placing the bucket a force corresponding to about 10 kg needs to be applied so that the bucket settles itself.
- The sensor reports the raw accumulated precipitation amount. The time constant of the weight measurement is not reported. The raw measurements seem to be susceptible to vibrations fluctuations that are induced by the impact of precipitation in the bucket.

### **3.16. MPS System TRwS**

The TRwS is a weighing rain gauge with a collector area of 500 cm<sup>2</sup>. The precipitation is collected in a bucket with a capacity corresponding to 270 mm of precipitation before manual emptying is required. The bucket rests on a so-called tenzometric bridge that determines the weight of the bucket. The internal sensor software applies corrections for wind- and particle induced vibrations, evaporation, temperature fluctuations and faulty events. Details of the software filter are not given. The sensor calculates the precipitation sum over 1-minute intervals, the total weight of the bucket and a precipitation indicator. The data can be requested via a serial interface. The 1-minute precipitation amount has an update time of 1 minute. The manufacturer's documentation mentions that the "increment of precipitation can be within 2 minutes". The accuracy reported by the manufacturer is 0.1 %. The resolution of the sensor is 0.001 mm. The manufacturer specifies an intensity range of 0-600 mm/h.

The test results of this sensor are shown in Appendix 16 and are summarized in Figure 45. The sensor reports a 1-minute precipitation sum that is updated every minute and the instantaneous weight of the bucket. Both values are converted into running 1-minute averaged intensities and averaged over the entire time interval of the intensity run except for the first 3 minutes in order to account for the start-up effects and the delay of the sensor. The reference intensity is calculated from the decrease in mass of the reservoir on a scale over the same time interval. The evaporation rate was measured for intensities below 200 mm/h and taken into account whereas an evaporation rate of 0.05 mm/h was adopted for the higher intensities. Figure 45 shows that both TRwS instruments are within the  $\pm 5$  % limits of the reference. The error curves are even within  $\pm 1$  %, except at 2 and 600 mm/h where both instruments underestimate the intensity by about  $-2$  and  $-3$  % for instrument A and B respectively. The sensor results obtained from the mass of the bucket do not show the underestimation at 600 mm/h and are generally even closer to the reference than the intensity results. The underestimation of the intensity reported by the sensor at 2 mm/h also holds for the masses and is probably caused by evaporation of water in the bucket. The differences between both instruments are within  $\pm 1$  %.

## TRwS

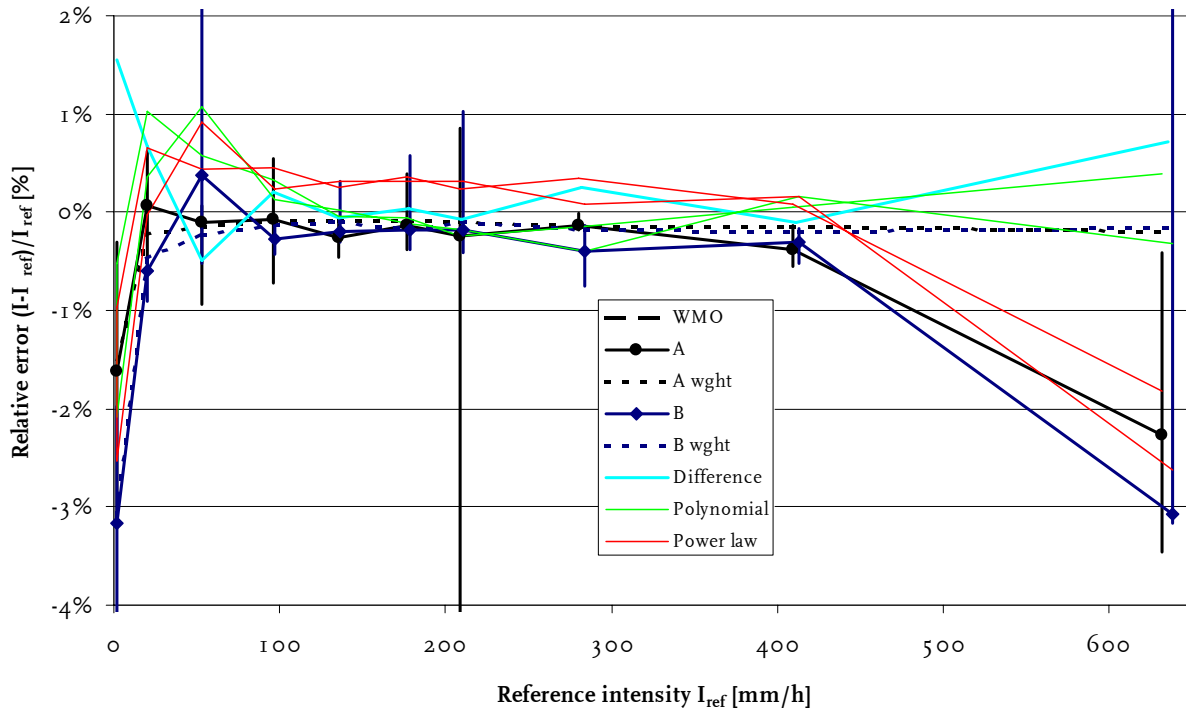

Figure 45: Summary of the test results of the TRwS instruments showing the averaged test results of both instruments versus the reference intensity, the relative difference between the results obtained for both instruments, and the errors after a correction using the second order polynomial or power law fit has been applied to the data. The sensor results are obtained averaging the reported 1-minute intensities (solid lines) and by averaging the running 1-minute intensities derived from the change in weight of the bucket (dashed lines).

Time series of the running 1-minute averaged intensities derived from the TRwS sensor and reference are shown in Figure 46. Sensor results are shown for the 1-minute precipitation amount and the mass of the bucket. In all situations the intensity and mass results of the sensor show some small variations around the reference intensities. The time series clearly show the delay of the TRwS sensor. The delay of the reported intensity is up to 2 minutes. The reported mass is updated every 10-seconds and therefore the results for the mass have generally a shorter delay. In 1 case (instrument A 200 mm/h run 5) the delay of the intensity was 4 minutes whereas the mass showed no additional delay. The time series at 600 mm/h illustrates the underestimation of the sensor's intensity results that are not present in the mass. Since the mass and intensity values of the sensor are not consistent, the sensor software must reject precipitation even under constant flow conditions.

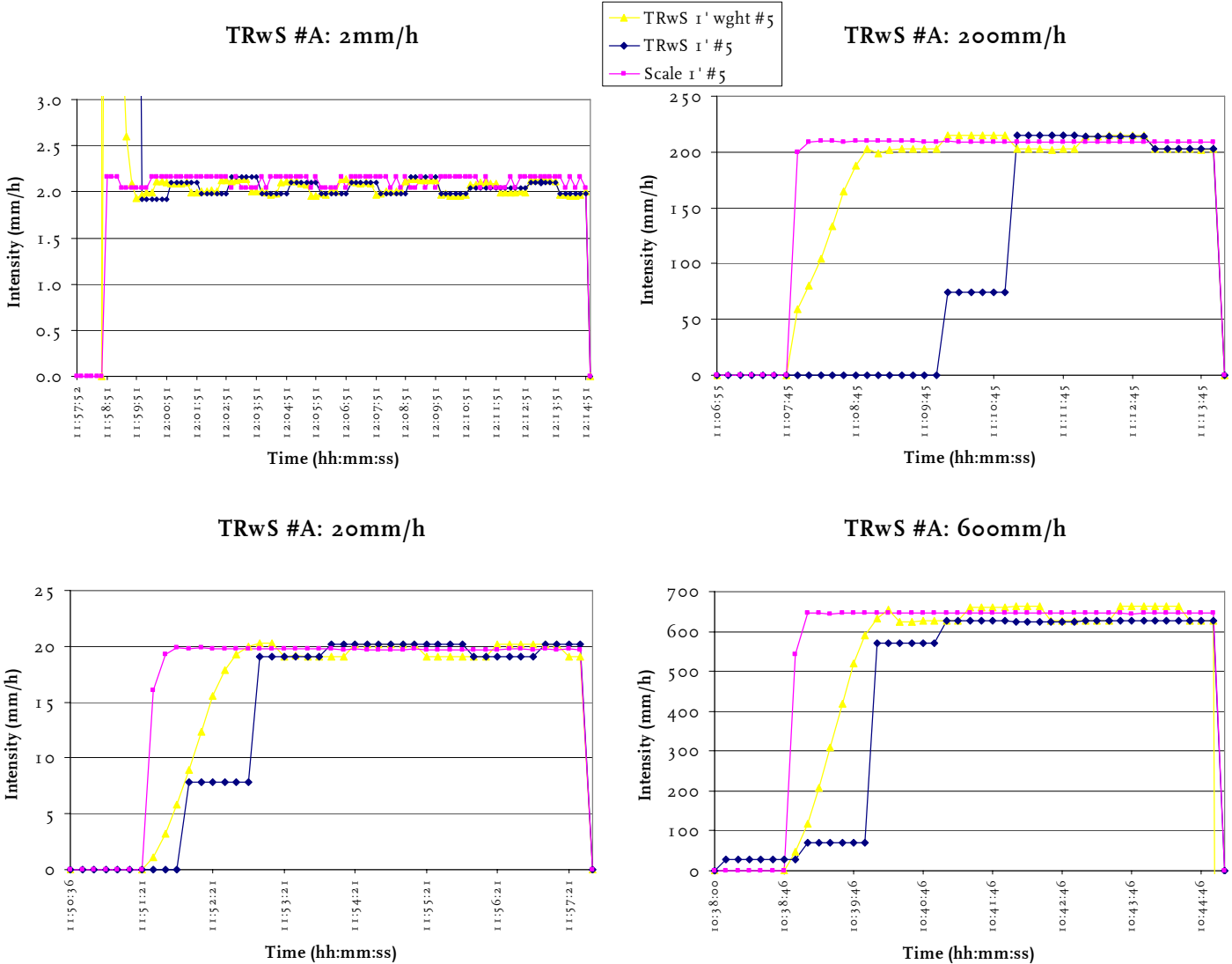

Figure 46: Time series of the running 1-minute averaged intensities of the reference and the TRwS A instrument during run 5. Sensor results are derived from the 1-minute precipitation amount (blue) and the mass of the bucket (yellow). The vertical labels denote 1-minute intervals.

Figure 47 shows the results of a step response test with sufficiently long time intervals before and after the test in order to verify the total precipitation sums. Comparison of the intensities showed that the averaged reference intensity of 210.1 mm/h is underestimated by  $-0.3$  and  $-0.1$  % for the intensity and mass results of the sensor respectively. The larger underestimation of the intensity compared to the mass results of the sensor are compensated after the run when the intensity reported higher values compared to the mass. The total sum of 52.0 mm was overestimated by 0.6 % by both sensor results. However, in this case the small underestimation is probably caused by the phase shift between the sensor intensities which both alternate between about 203 and 215 mm/h.

### Step response TRwS A

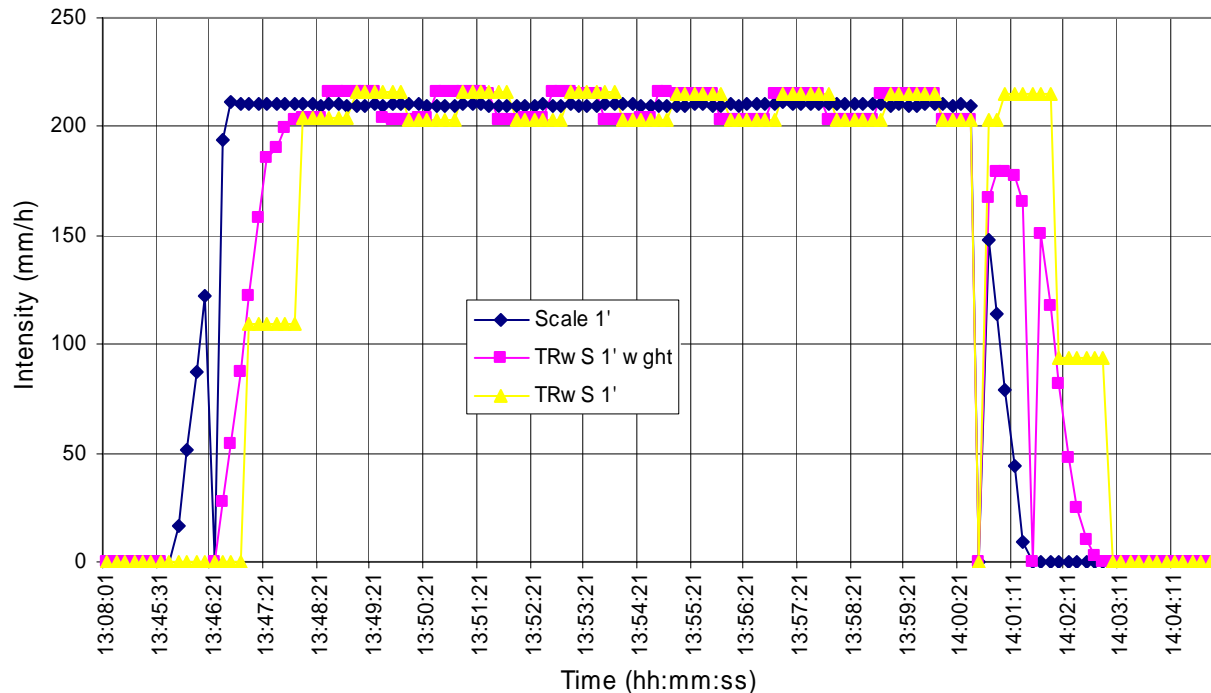

Figure 47: Time series of the running 1-minute averaged intensities of the reference and the TRwS A instrument during run 5. Sensor results are derived from the 1-minute precipitation amount (blue) and the mass of the bucket (yellow). The vertical labels denote 1-minute intervals.

Comments related to the TRwS sensor are:

- The tests for this instrument were performed with a sample interval of 10 s.
- The evaporation of the reservoir on the unused scale was measured for intensities up to 200 mm/h and ranged between 0.02 and 0.08 mm/h. This measured evaporation value is compensated in the data analysis. An evaporation of 0.05 mm/h was adopted for intensities above 200 mm/h.
- There is no spirit level on the sensor for alignment.
- The 3 pylons to support the housing were loose for instrument A (one screw is worn).
- The sensor sheet specifies a pulse output, but this is not clearly indicated in the TRwS description and the +/- contact in the electronic box underneath the support plate cannot easily be reached. Therefore only the serial data output is used.
- The software version of the sensor is not reported in the manual nor is it given by the sensor interface.
- Details on the software processing and filtering are not given. Hence the observed inconsistencies between intensity and mass output cannot be explained.
- The data string contains 6 instead of the 8 variables as shown in the manual, and only 3 of the variables are described.

- The manufacturer “specified” a delay of 2. However, a delay of 3 minutes and at one occasion 4 minutes was observed. A delay of 3 minutes was adopted in the analysis in this report.

### 3.17. Lambrecht 1518H3

The 1518H3 is a tipping bucket rain gauge with a resolution of 0.1 mm and a collector area of 200 cm<sup>2</sup>. The instrument has a reed switch output and applies no correction. The manufacturer states that the accuracy of the sensor is ±2 % when an intensity correction is applied. However, details on this correction are not supplied. The intensity range of the 1518H3 is 0-600 mm/h.

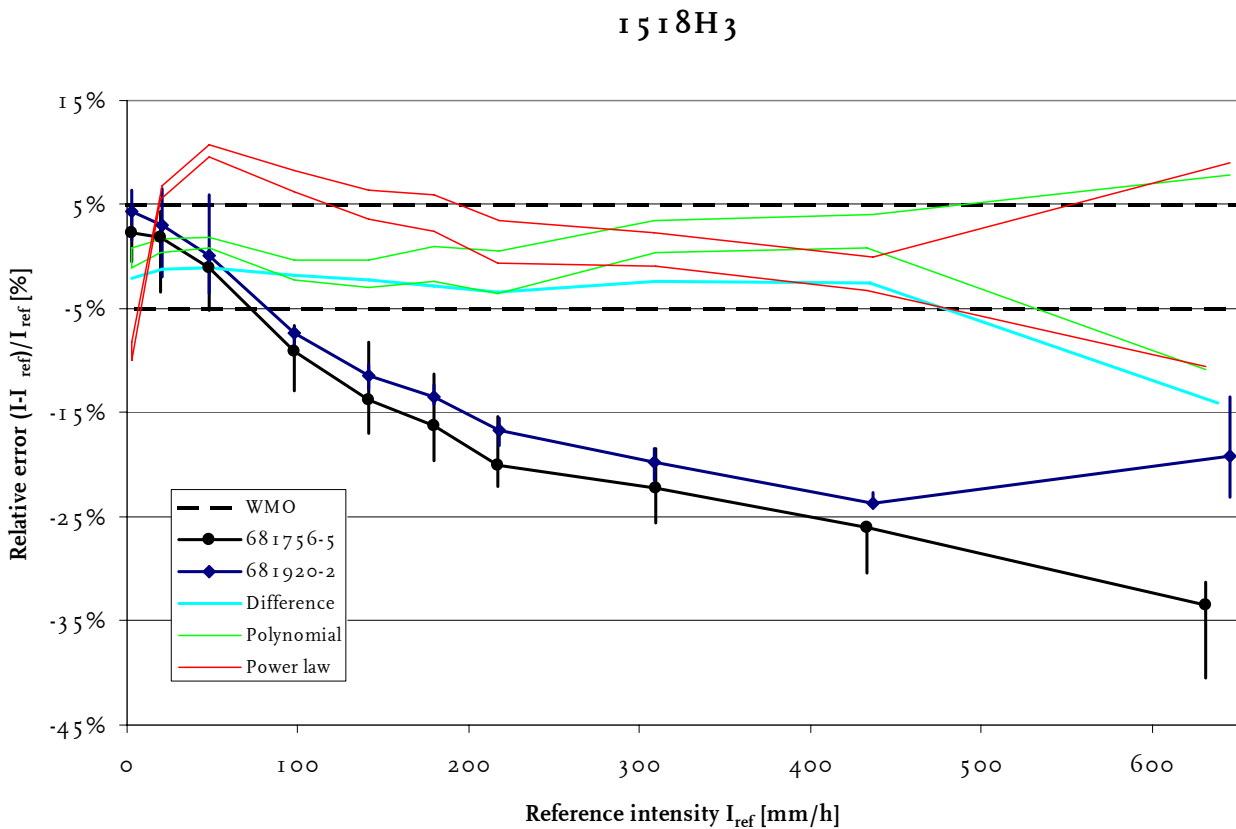

Figure 48: Summary of the test results of the 1518H3 instruments showing the averaged test results of both instruments versus the reference intensity, the relative difference between the results obtained for both instruments, and the errors after a correction using the second order polynomial or power law fit has been applied to the data.

The test results of this sensor are shown in Appendix 17 and are summarized in Figure 48. The results of this sensor show the characteristic underestimation of for tipping bucket rain gauges. The errors cross 0 % near 50 mm/h. At lower intensities the sensor overestimates the precipitation amount, whereas at high intensities the sensor underestimates the intensity up to nearly -25 and -35 %. The results for both instruments

are quite consistently within 2-3 %, except at the highest intensity of 600 mm/h where the 2 instruments differ 14 %. Sensor 1 always gives lower intensities compared to sensor 2. The differences can be nicely fitted by a second order polynomial and after a correction with this polynomial fit the results fall within the  $\pm 5$  % limits set by WMO, except at 600 mm/h. The latter could be expected since the results of both instruments differed largely at 600 mm/h. A correction of the form of a power law fit gives, in addition, unsatisfactory results at low intensities below about 100 mm/h.

Figure 49 shows the distribution of the time intervals between 2 consecutive increments of the accumulated precipitation reported for all 5 test runs at the reference intensity of 2 mm/h for both 1518H3 instruments. The distribution of both instruments is very similar. The averaged time between consecutive tips is 152 and 150 s for sensors 1 and 2 respectively, which corresponds to intensities of 2.36 and 2.40 mm/h. The standard deviation of the time between consecutive tips is 5 (3) and 6 s (4 %) for sensors 1 and 2, respectively.

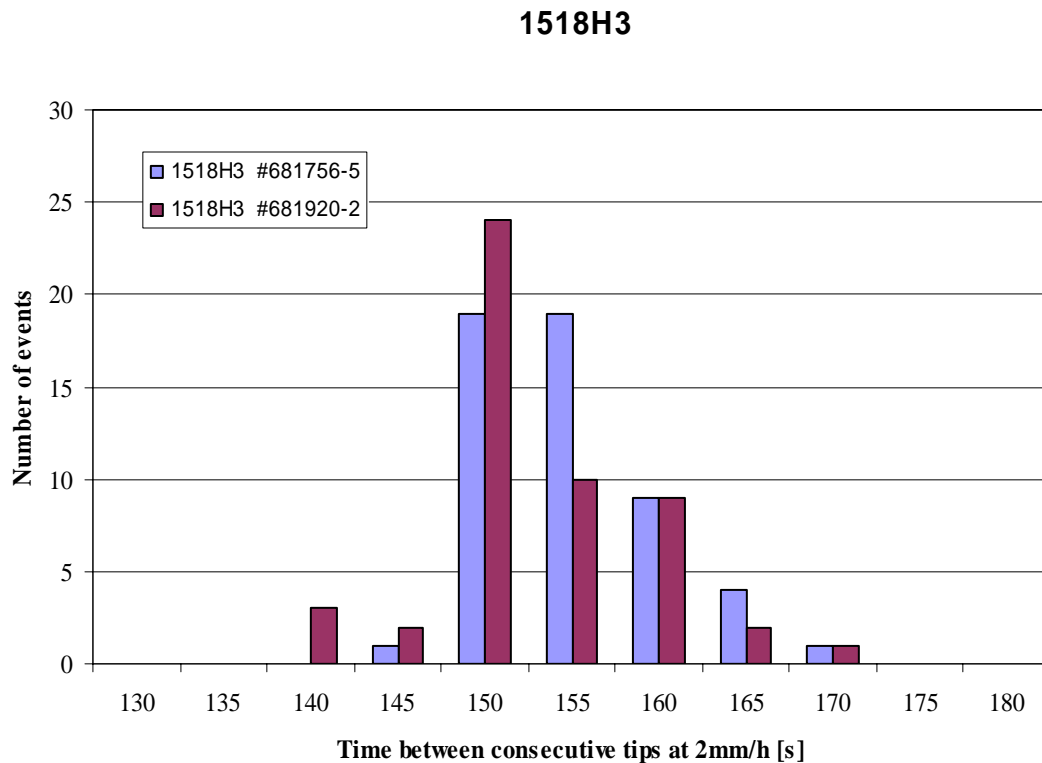

Figure 49: Histogram of the observed time intervals between consecutive tips for both 1518H3 instruments at 2 mm/h. The time denoted at the x-axis is the end time of the time interval, hence 3 tips occurs between 135 and 140 s.

Comments related to the 1518H3 sensor are:

- The tests for this instrument were performed with a sample interval of 5 s.
- The evaporation was measured and taken into account for all reference intensities. Evaporation ranged between 0.1 and 0.4 mm/h.

- There is a version of the sensor with a data logger and the manufacturer also has a tipping bucket rain gauge with a resolution of 0.4 mm for heavy rainfalls. The sensor considered in this test had a resolution of 0.2 mm and no data logger.
- Sensor 2 starts tipping irregularly at about 400 mm/h. The tipping balance bounces back and causes additional tips before the tipping collector is full.
- The tipping mechanism of sensor 1 got stuck on 2 occasions at 416mm/h and was released manually. This was probably caused by a shift upwards of the tip mechanism during a bounce after a tip.
- The spirit level is located underneath the funnel so that one cannot check the alignment of the sensor from above without reading errors.
- The sensors were delivered without the debris protection spiral mentioned in the documentation.
- The sensor shows hardly any spatter even at 600mm/h.

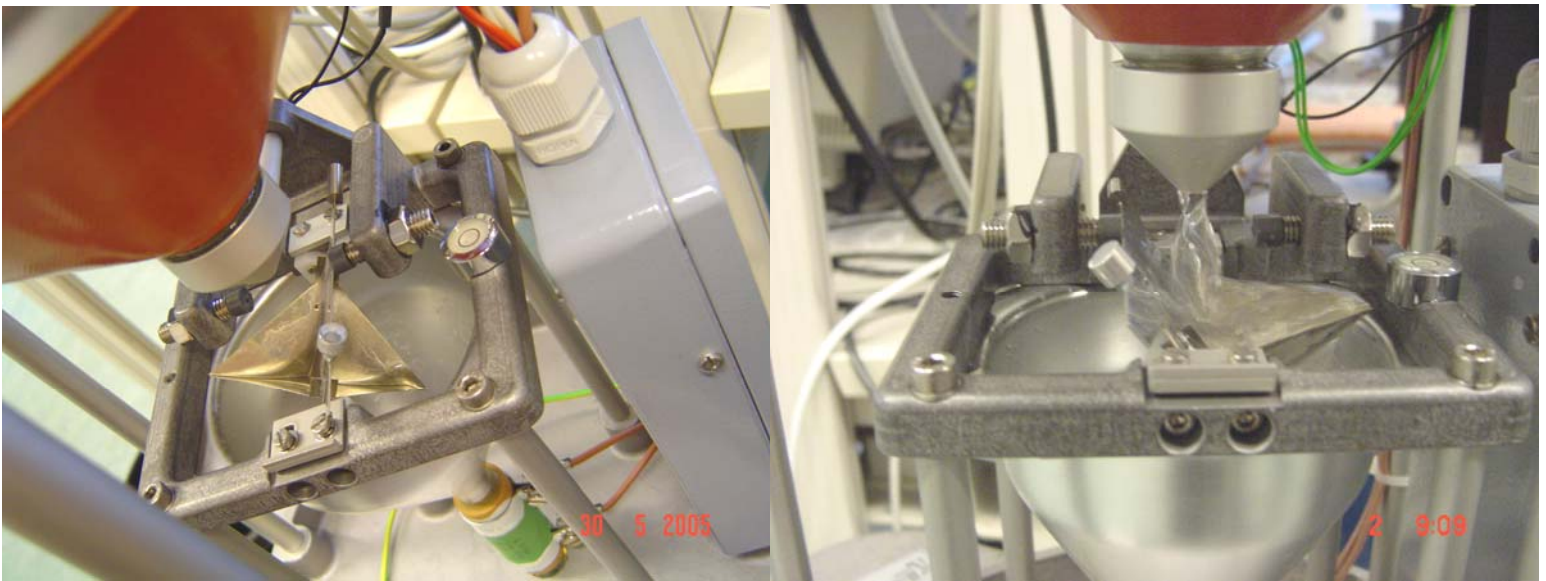

Figure 50: Photographs of the 1518H3 sensor showing a droplet remaining in the emptied tipping bucket (left) and a situation when the tipping balance got stuck (right).

### **3.18. Casella CEL Ltd. 100000E**

The 100000E is a tipping bucket rain gauge with a resolution of 0.2 mm and a collector area of 400 cm<sup>2</sup>. The instrument has a reed switch output and applies no correction. The manufacturer states that the accuracy of the sensor is  $\pm 1\%$  at 1 l/h, i.e. 2.5 mm/h. The intensity range of the 100000E is not specified in the operator's handbook, but was 0-500 mm/h.

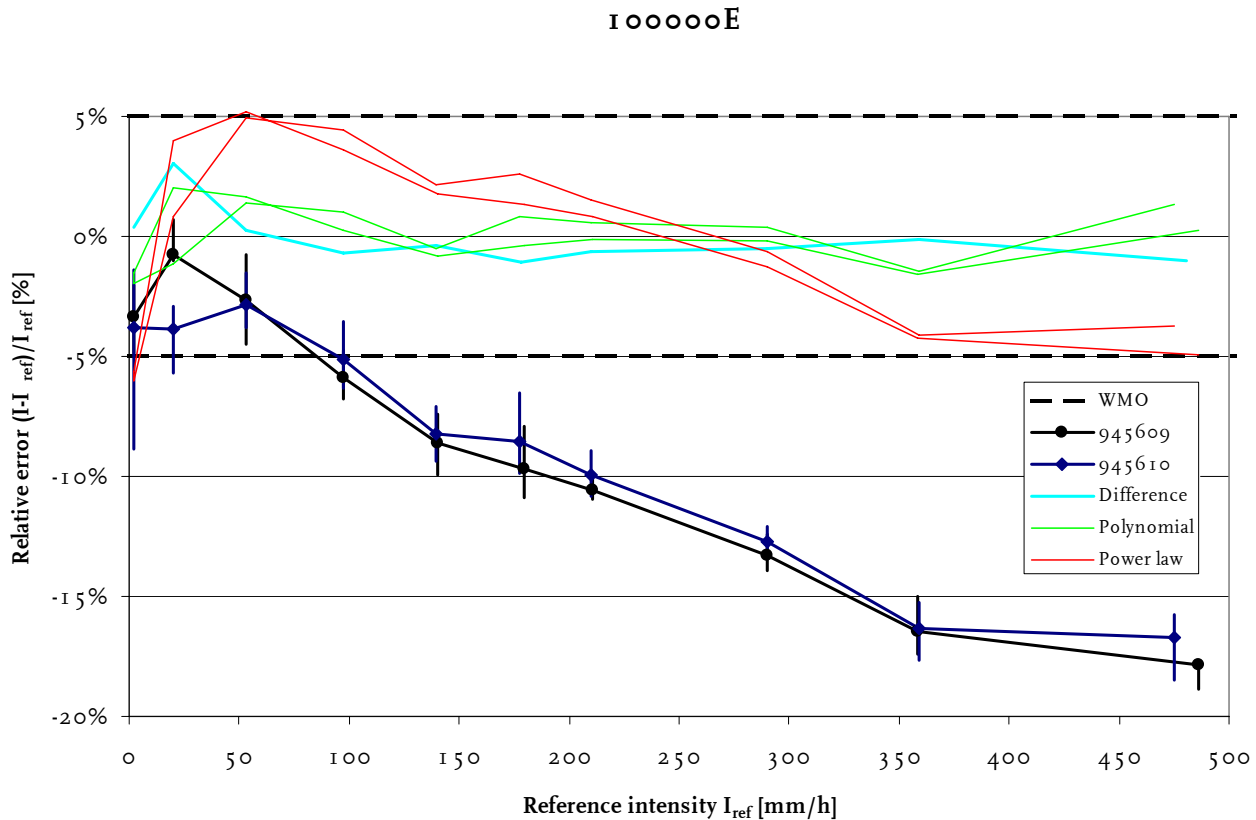

Figure 51: Summary of the test results of the 100000E instruments showing the averaged test results of both instruments versus the reference intensity, the relative difference between the results obtained for both instruments, and the errors after a correction using the second order polynomial or power law fit has been applied to the data.

The test results of this sensor are shown in Appendix 18 and are summarized in Figure 51. The results of this sensor show the characteristic underestimation of for tipping bucket rain gauges. Both instruments underestimate precipitation at all reference intensities. At high intensities the sensor underestimates the intensity up to about  $-17\%$ . The results for both instruments are quite consistently within  $1\%$ , except at  $20\text{ mm/h}$  where the 2 instruments differ  $3\%$ . Sensor 1 gives lower values compared to sensor 2 for reference intensities above  $50\text{ mm/h}$ . The differences can be nicely fitted by a second order polynomial and after a correction with this polynomial fit the results fall within  $\pm 2\%$  from the reference at all intensities. A correction of the form of a power law fit gives worse results and places the corrected results close to the  $\pm 5\%$  at low and high intensities.

Figure 49 shows the distribution of the time intervals between 2 consecutive increments of the accumulated precipitation reported for all 5 test runs at the reference intensity of  $2\text{ mm/h}$  for both 100000E instruments. The distribution of both instruments is very similar, except for the tips at  $390\text{ s}$  for sensor 2. The averaged time between consecutive

tips is 360 and 363 s for sensors 1 and 2 respectively, which corresponds to intensities of 2.00 and 1.98 mm/h. The standard deviation of the time between consecutive tips is 8 (2) and 18 s (5 %) for sensors 1 and 2, respectively. The large standard deviation for sensor 2 is caused by the results obtained in run 4 during which 5 tips between 390 and 415 s were observed.

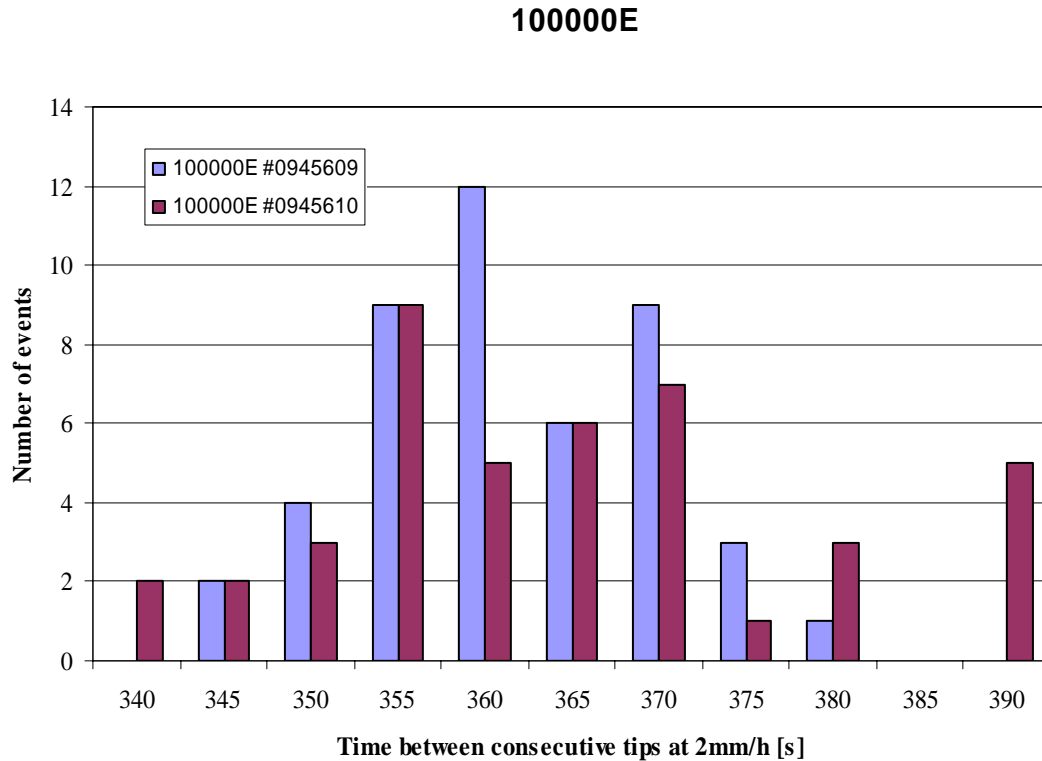

Figure 52: Histogram of the observed time intervals between consecutive tips for both 100000E instruments at 2 mm/h. The time denoted at the x-axis is the end time of the time interval, hence 2 tips occurs between 335 and 340 s.

Comments related to the 100000E sensor are:

- The tests for this instrument were performed with a sample interval of 5 s.
- The evaporation was measured and taken into account for reference intensities up to 271 mm/h. Evaporation ranged between 0.05 and 0.11 mm/h. At higher intensities an evaporation rate of 0.08 mm/h was adopted.
- The opening in the funnel is rather small and limits the intensity to about 500 mm/h.
- The sensor shows a little spatter at 500 mm/h.
- At 500 mm/h about 5 mm of water accumulates in the funnel.
- The tips occur regularly over the whole intensity range.

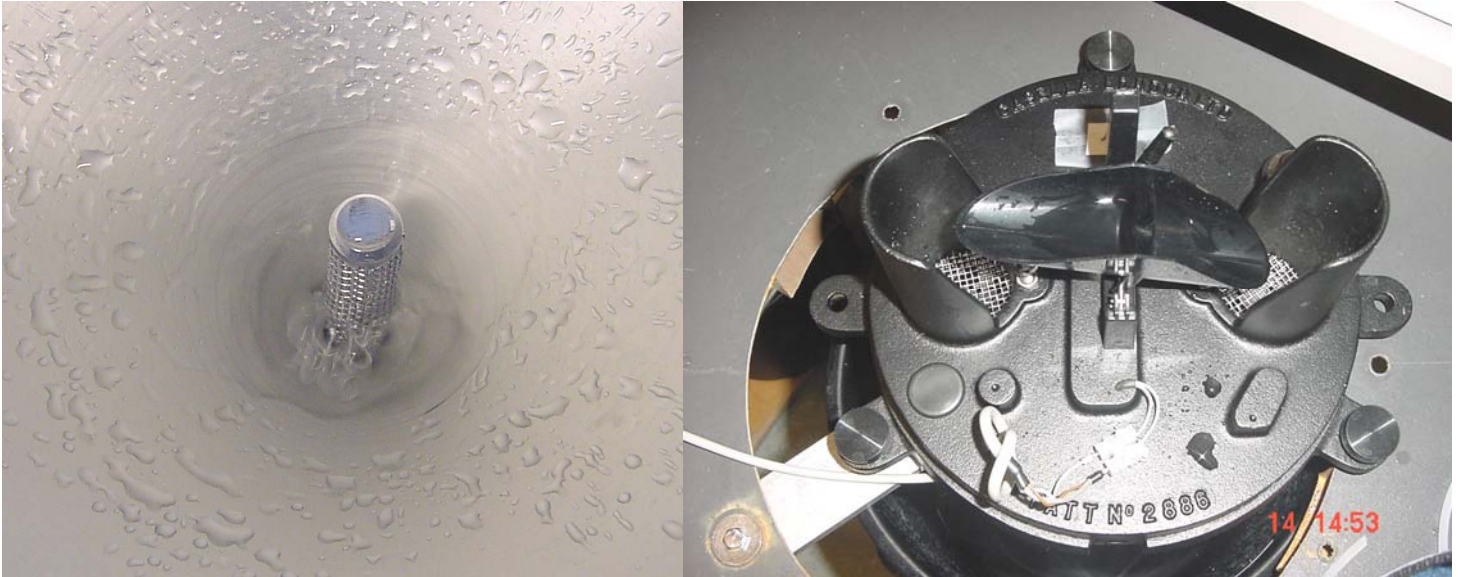

Figure 53: Photographs of the 100000E sensor showing accumulation of water in the funnel at 500 mm/h (left) and the small amount of spatter after a run of 500 mm/h (right).

### 3.19. Design Analysis Ass. H-340SDI

The H-340SDI is a tipping bucket rain gauge with a resolution of 0.01 in (0.254 mm) and the collector diameter is 8 in (area of 324.3 cm<sup>2</sup>). The instrument has a reed switch contact. The built-in electronics of the sensor registers the time between successive pulses and applies an intensity dependent correction. The correction is of the form of a polynomial that produces at low intensities 0.009 in/tip increasing up to 0.013 in/tip at 30 in/h. The manufacturer does not give the accuracy of the sensor. The sensor has a serial output that reports amongst others the number of tips since the last measurement and the accumulated rainfall. The manufacturer gives the intensity range of the H-340SDI as 25 in/h, i.e. 0-635 mm/h. Although test showed that the sensor could possibly measure up to 1000 mm/h. The analysis of the results is, however, restricted to 635 mm/h.

The test results of this sensor are shown in Appendix 19 and are summarized in Figure 54. Only one H-340SDI instrument was available for this test. Since both the raw number of tips as well as a corrected precipitation amount are reported by this sensor, results of both are discussed. The results of the raw tips show the characteristic underestimation of tipping bucket rain gauges and the errors vary from +14 % at 2 mm/h to -15 % at 635 mm/h. The error is 0 % at about 200 mm/h. The errors of the corrected results vary less with intensity. The corrections applied vary from -8 to +24 %. However, the corrected results always overestimate precipitation by about +7±2 %, except at 50 and 432 mm/h where the errors are +1 and +13 %, respectively. At 20, 50 and 130 mm/h the sensor sometimes shows large underestimations when the droplets miss the tipping bucket (see comments). The differences can be fitted by a second order polynomial and after a correction with this polynomial fit the corrected and raw results are nearly identical and fall within ±3 % from the reference at all intensities. A correction of the form of a power law fit gives slightly worse results for the corrected output, but still within the ±5 % limits set by WMO. The power law fit correction to the raw results

performs less and does not place the raw results within the  $\pm 5\%$  limits at 2 and 635 mm/h.

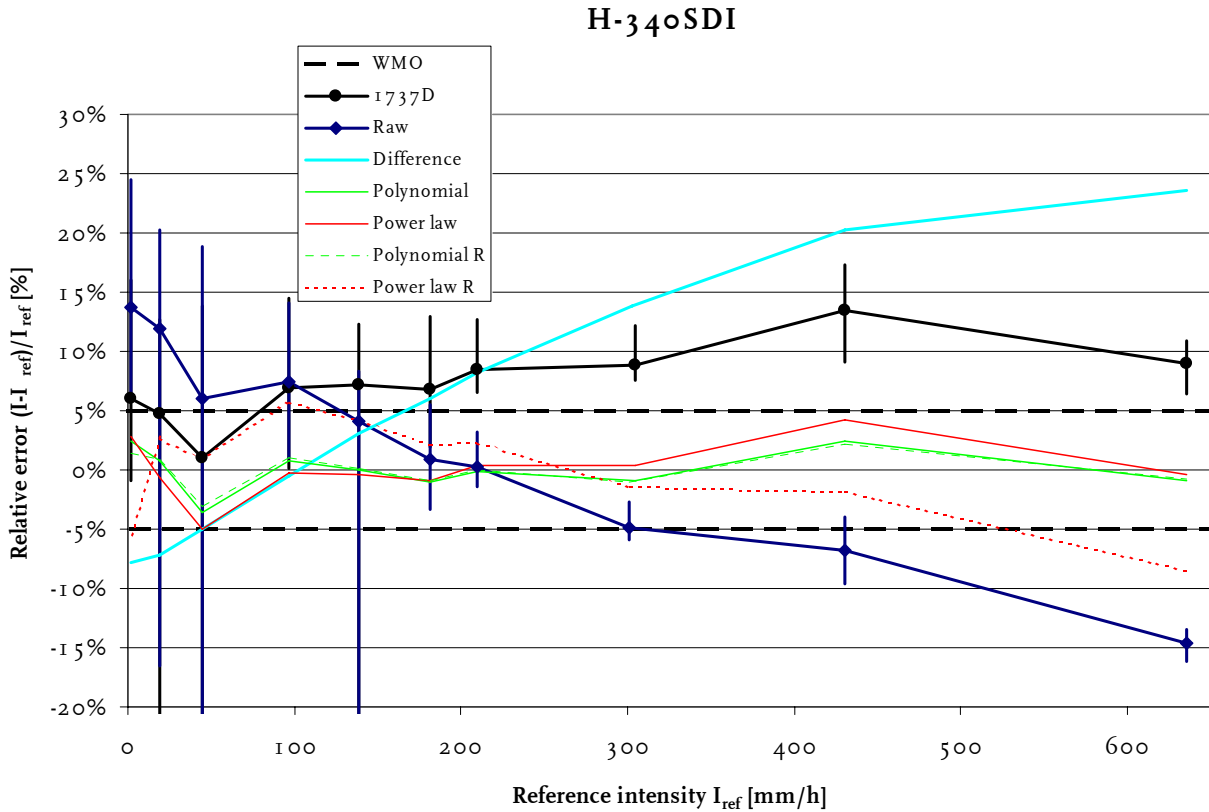

Figure 54: Summary of the test results of the H-340SDI instruments showing the averaged test results of the raw and the corrected output versus the reference intensity, the relative difference between the results obtained for the instruments, and the errors after a correction using the second order polynomial or power law fit has been applied to the data.

Figure 55 shows the distribution of the time intervals between 2 consecutive increments of the accumulated precipitation reported for all 5 test runs at the reference intensity of 2 mm/h for the H-340SDI instrument. The distribution of the histogram is rather broad and seems to consist of 2 separate distributions, one between 335 and 375 s and another between 385-445 s. Generally, events occur in both sets during a test run, except in run 2 and 5 where all measured intervals were between 385-445 s. Hence the 2 distributions are not caused by the odd and even tipping events as a results of a bad alignment of the tipping balance. The averaged time between consecutive tips is 400 s, which corresponds to an intensity of 2.29 mm/h. The standard deviation of the time between consecutive tips is 33 s (8 %).

### H-340SDI

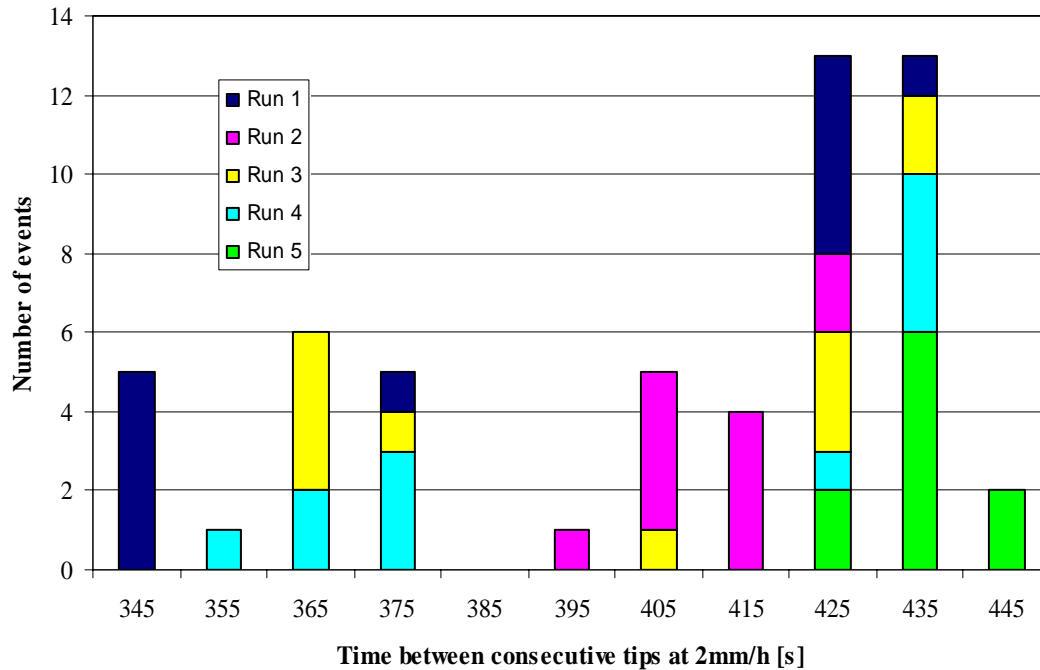

Figure 55: Histogram of the observed time intervals between consecutive tips for the H-340SDI instrument at 2 mm/h. The time denoted at the x-axis is the end time of the time interval, hence 2 tips occurs between 435 and 445 s. The 5 tips in the first bar all occurred between 330 and 335 s during run 1.

Comments related to the H-340SDI sensor are:

- The tests for this instrument were performed with a sample interval of 5 s.
- The evaporation was measured and taken into account for reference intensities up to 294 mm/h. Evaporation ranged between 0.05 and 0.19 mm/h. At higher intensities an evaporation rate of 0.10 mm/h was adopted.
- The manufacturer of the sensor provided an SDI-12/RS232 interface so that the sensor can be connected to the COM port of the PC.
- Only one sensor was made available for this test.
- The fact sheet specifies a maximum intensity of 25 in/h, i.e. 635 mm/h. Tests showed, however, that the sensor can handle intensities up to 2000 mm/h although about 5 mm of water accumulates in the funnel at intensities above 1000 mm/h and the sensor starts tipping irregularly at intensities of about 800 mm/h.
- The output of the sensor is reported in mm and not inches as specified by in the manual. This is consistent with the internal setting of the slope of the rainfall accumulation of 25.4, i.e. the scale factor from inches to mm.
- The sensor software version is 1.2.
- The sensor has a window for checking the tipping mechanism. This turned out to be very useful for tracing the missing precipitation mentioned below.

- The debris protection filter, which covers the full width of the funnel, was not used in these tests.
- When the sensor is wet internally (particularly the bottom of the metal plate above the tipping bucket and the funnel exit) the droplets do not always fall vertically in the tipping bucket, but the droplets are pulled sideward by osmosis and miss the bucket. This was particularly the case for runs at 20, 50 and 130 mm/h. In that case the sensor shows a lot of internal spatter and largely underestimates the intensity. When the sensor was wetted manually, only 2 and 1 tips were observed at 20 and 50 mm/h instead of the expected 21 and 52 tips.
- The sensor shows no spatter up to about 635mm/h, but above 1000mm/h the sensor shows spatter inside. Only in situations of the droplets missing the tipping bucket the sensor also gets wet at low precipitation intensities.



Figure 56: Photographs of the h-340SDI sensor showing water droplets being pulled sideward and missing the tipping bucket when the sensor is internally wet.

### **3.20. KNMI Neerslagmeter**

The Neerslagmeter is a rain gauge, which measures the amount of precipitation by means of a water level measurement. The sensor has a catching area of area of  $400 \pm 0.5 \text{ cm}^2$ . Precipitation is collected in a reservoir with a surface area of  $50.2 \pm 0.1 \text{ cm}^2$ . A float is located in the reservoir and is connected to a potentiometer. The sensor is connected to a sensor interface, which performs a measurement every 12 seconds. The change in the

water level is measured every 12 seconds with a resolution equivalent to 0.001 mm of precipitation. The precipitation intensity is calculated from the change in water level since the previous measurement and running averages over 1 and 10 minutes are reported as well. Hence, the resolution of the sensor is 0.3, 0.06, 0.006 mm/h for intensities evaluated over 12-seconds, 1-minute and 10-minute time intervals, respectively. The reservoir has a capacity equivalent to 110 mm of precipitation and is emptied when it is nearly full. Emptying is performed automatically and takes about 15 seconds during which the last measurement is persisted. After emptying about 10 mm of water is retained in the reservoir. The sensor interface uses a correction of 0.06 mm in order to compensate for hysteresis of the float after emptying. The sensor checks for leakage of the reservoir, which can be caused by debris that remains in the shutter after emptying the reservoir. Furthermore, evaporation and temperature effects can cause negative changes to the water level in the reservoir. These negative readings are detected and the reduced level serves as the reference for reporting future precipitation amounts. The reported accuracy of the sensor is  $\pm 2\%$  over the full range. The measuring range of the Neerslagmeter is 0 to 300 mm/h. Since the sensor interface gives errors in case a single 12-second measurement exceeds 300 mm/h, an upper limit of 270 mm/h was used in this test.

The test results of the Neerslagmeter are shown in Appendix 20 and are summarized in Figure 57. These results have been obtained by averaging the reported 1-minute averaged precipitation intensity for each intensity run. The sensor results during the first minute of the intensity run are ignored in order to filter out start-up effects. The averaged 1-minute sensor intensities are compared to the averaged reference intensity over the same time interval in the top panel of Figure 57. The results of both instruments show good agreement to each other. They differ less than  $\pm 1\%$  up to 200 mm/h and  $\pm 2\%$  for higher intensities. The averaged sensor results show a dependency on intensity. The deviation with the reference is within  $\pm 1\%$  up to 50 mm/h, but then the sensor underestimates precipitation up to about  $-10\%$  at 270 mm/h. This underestimation is related to errors that occur during emptying of the reservoir, which are discussed in more detail in Figure 59. The different number of emptying events for each run largely determines the variability in the sensor results. Applying the second order polynomial and the power law fit and their corresponding corrections the averaged raw sensor results places the results within the  $\pm 5\%$  limits set by WMO at all intensities. The second order polynomial correction is more suitable for reproducing and hence reducing the intensity dependence of the sensor. The lower panel shown the same results, but now the periods when the sensor emptied are not considered. The emptying periods could be determined, except for some faulty periods within 1-minute after start-up of an intensity run, by the intervals where the 12-second sensor intensity deviated more than 10% from the 1-minute averaged reference intensity. Without the emptying events the agreement between the Neerslagmeter and the reference is nearly within  $\pm 1\%$  for both instruments for the entire intensity range. The agreement between the 2 instruments is mostly within  $\pm 0.5\%$ . Both instruments show a small offset of about  $+1\%$  and  $+0.7\%$  for instrument 1 and 2, respectively. This offset can be eliminated by a correction based on either the second order polynomial fit or the power law fit.

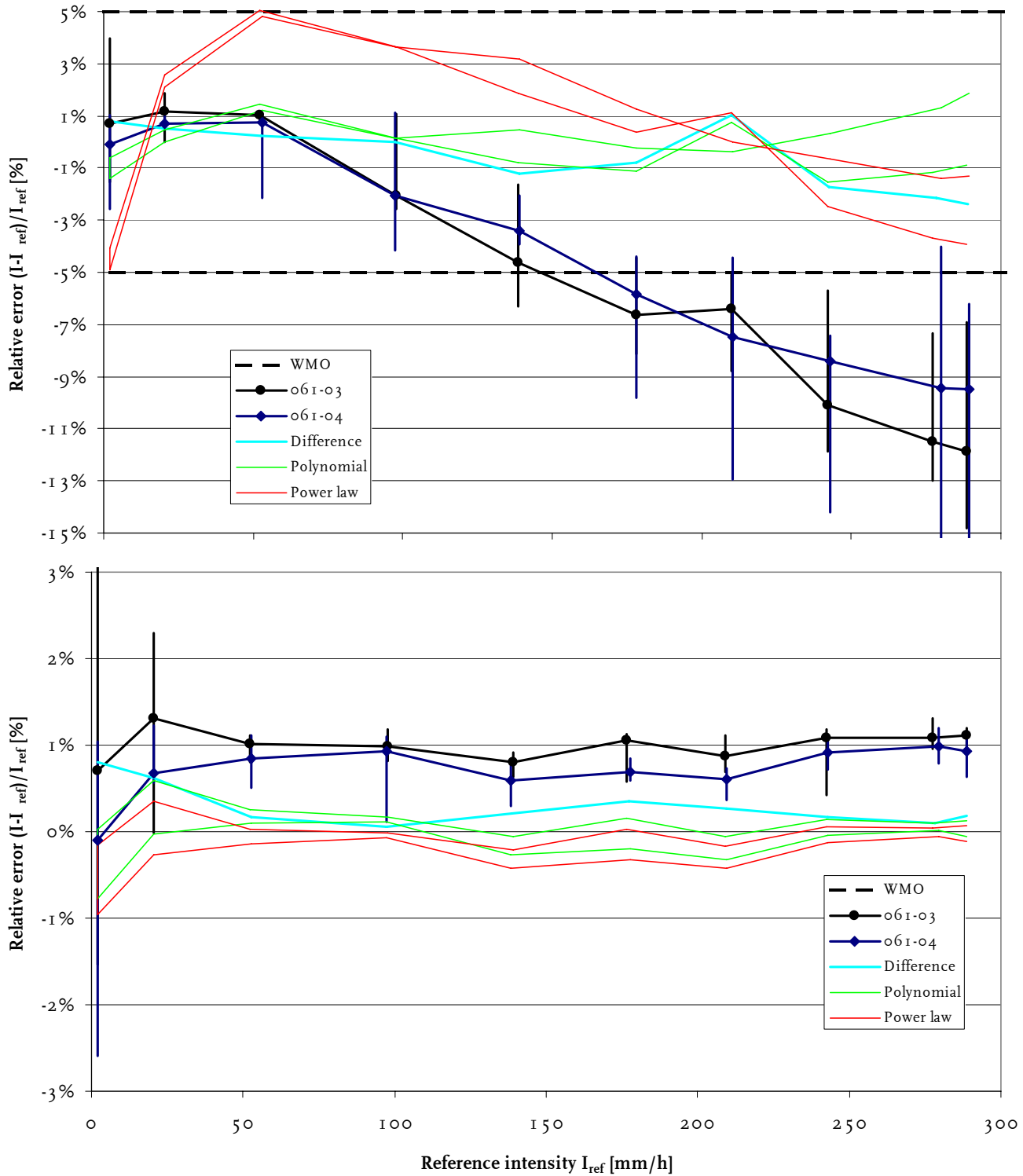

Figure 57: Summary of the test results of the Neerslagmeter instruments showing the averaged test results of both instruments versus the reference intensity, the relative difference between the results obtained for both instruments, and the errors after a correction using the second order polynomial or power law fit has been applied to the data. The top panel shows the raw sensor results, whereas in the lower panel the results during emptying are filtered out.

## KNMI sum

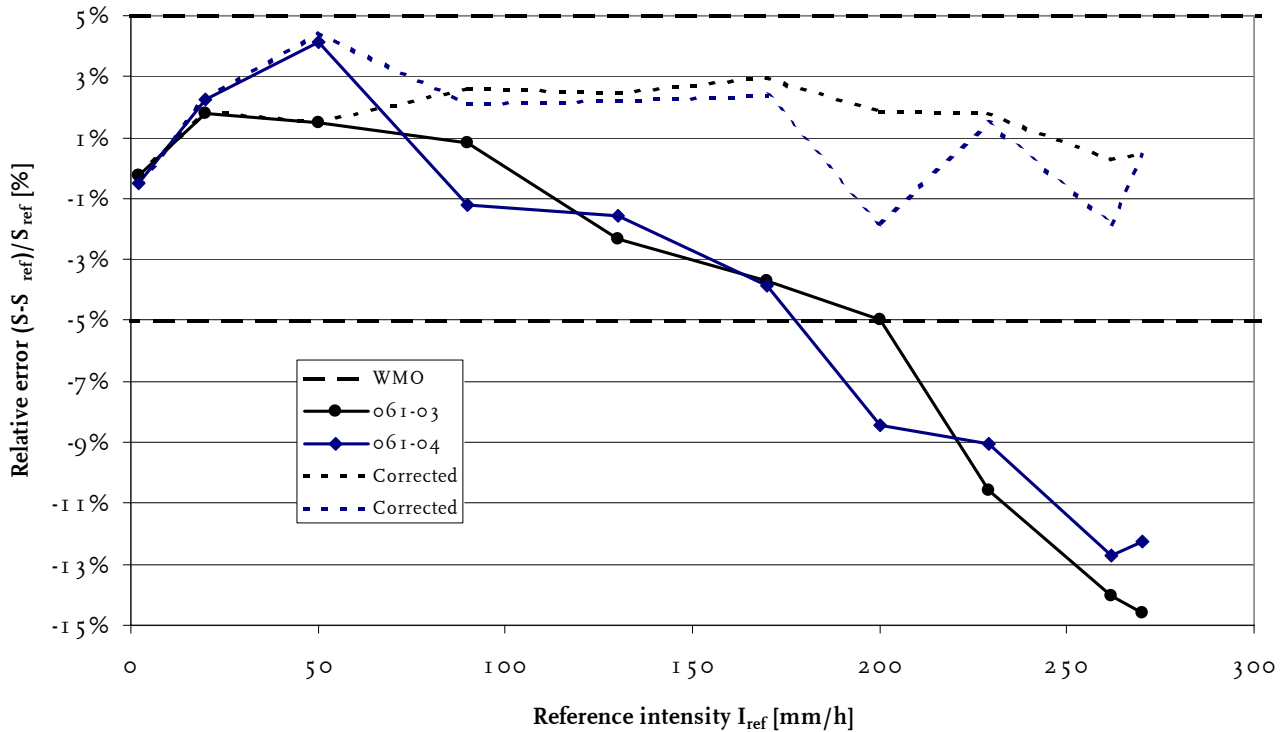

Figure 58: Summary of the test results of the Neerslagmeter instruments showing the relative difference of the total precipitation sums of the averaged test results of both instruments versus the reference. Solid lines show the raw sensor results, whereas in the dashed lines emptying is filtered out.

The intensity runs were performed in such a way that there was a delay of at least 1 minute around each intensity. This allows the calculation and comparison of the total precipitation sums that were injected as the reference and the sum obtained from the sensor. The comparison of the precipitation sums is given in Figure 58 as a function of intensity. The total precipitation sums of the raw sensor results show the same behavior as the intensity. At low intensities the errors increase from about 0 to 3 %, but at higher intensities the errors increase up to about -14 % at 270 mm/h. When the emptying events are filtered out the agreement between the sensor and the reference is much better, i.e. between -2 and +4 %. The differences between the sums of the corrected results are larger than for the corrected intensities, because the filter used for identifying emptying events does not work properly when emptying occurs at the end of an intensity run.

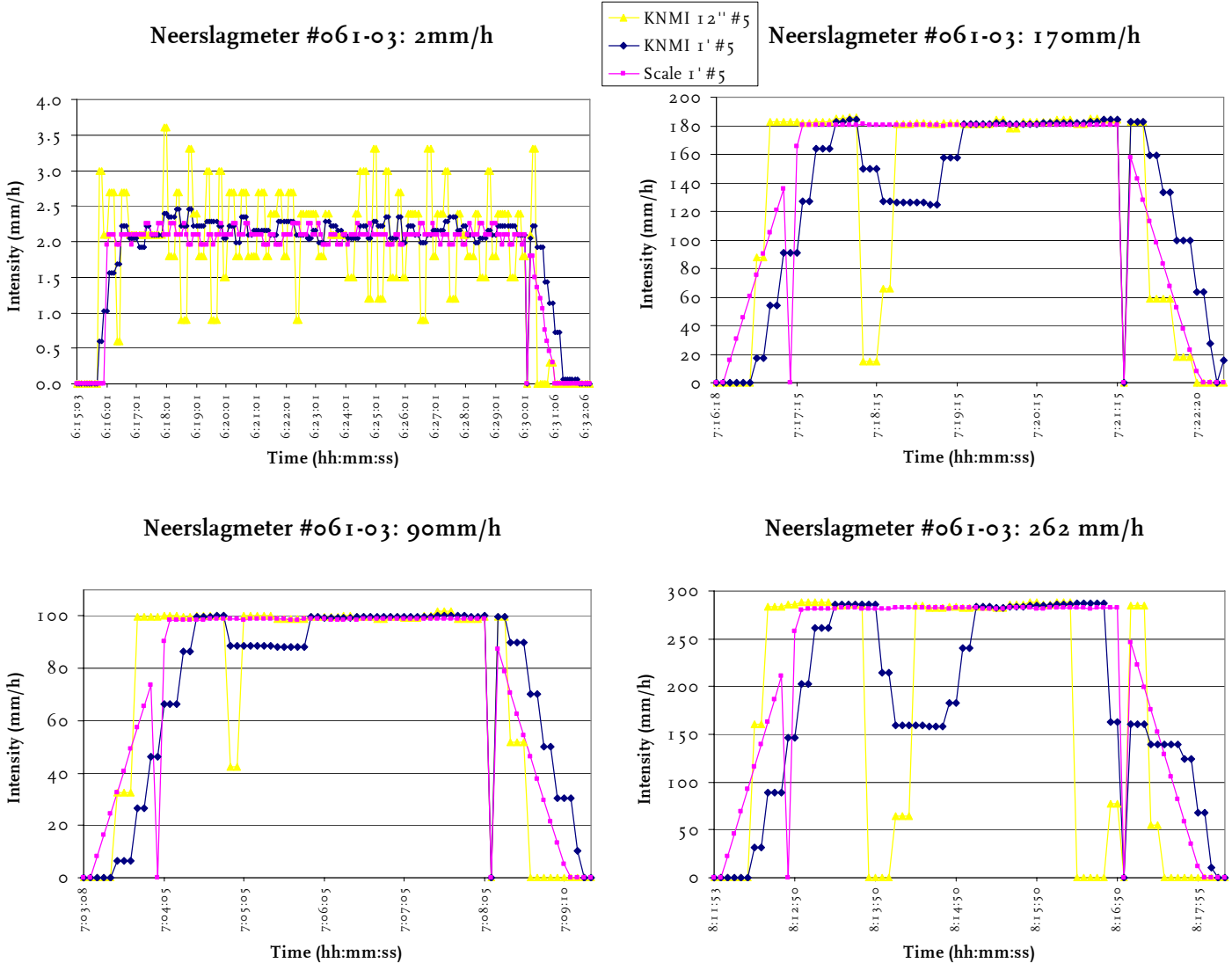

Figure 59: Time series of the running 1-minute averaged reference intensity and the corresponding 1-minute and 12-second intensity from the Neerslagmeter measurements of run 5 for instrument 061-03.

Time series of the 1-minute averaged intensities for the Neerslagmeter and the reference are compared in Figure 59. The running 1-minute averaged reference intensity is calculated from the decrease of mass of the reservoir over a running 1-minute period. The 1-minute averaged intensity is reported directly by the sensor. In addition the 12-second intensity reported by the sensor is shown. Since the sample interval is 5 seconds and the sensor interface gives an update of the intensities every 12 seconds every 2 or 3 reported sensor intensities are identical. The results at 2 mm/h (7  $\mu$ m in 12 seconds) show that the 12-seconds intensities of the sensor show large variability, which are the results of individual droplets contributing to the precipitation amount every 5 seconds at low intensities, variations in the water level due to the impact of droplets and the 0.3 mm/h resolution of the 12-seconds intensities. This variability is largely reduced in the running

1-minute averaged intensity. The curves at all intensities show that the delay of the sensor is everywhere within 36 seconds. Correct determination of the intensity requires at least one 12 second period under constant flow conditions, which may take up to nearly 24 seconds when the timing is such that the intensity run started just after the sensor interface performed a measurement. Furthermore, the sensor interface always lags one period of 12 seconds.

Next the emptying will be discussed in detail in order to explain the various types of underestimations that can be observed in Figure 59 at 90, 170 and 262 mm/h. For that purpose the internal operation of the sensor interface, which runs continuously a 12 second cycle, is given below.

- At second 0 the timer is reset and main is executed.
- At second 1 the current water level is determined and a flag is set so that the main code knows that a new sample is available for the calculation of the intensity.
- At second 2 it is checked (when the sensor is not already emptying) whether the emptying level is exceeded (level > 11000  $\mu\text{m}$ ) in which case shutter is opened and an internal status is set to Flushing and Emptying is true. The shutter closes automatically when the hardware set minimum level of about 1000  $\mu\text{m}$  is reached.
- At seconds 3-10 the sensor checks whether the internal status is Flushed in which case the previous level is set to the current level minus a hysteresis of 60  $\mu\text{m}$ . When the status is Flushing the interface checks if the shutter is closed in which case the internal status is set to Flushed.
- At second 11 the sensor checks whether the internal status is Flushed in which case the previous level is set to the current level minus a hysteresis of 60  $\mu\text{m}$ . In this last interval the status is not changed to Flushed.
- In the main code the intensity is persisted during Emptying, i.e. the previous water level change is added to the previous level and Emptying is set to false. The new current level is truncated at 11500  $\mu\text{m}$ . When the sensor is still Flushing the next 12-second interval (so emptying takes more than 21 seconds) the previous water level change is added to the previous level, but without truncation at the maximum level and a status error "W" is generated. Next, as in normal operation, the sensor interface determines current water level change level and sets the previous level to the current level for the next cycle. A negative change is set to zero. A decrease in the level of more than 0.1 mm in 12 seconds results in an update of the current level, whereas smaller changes are ignored. Finally the sensor interface performs in main a range check of the level and level change (600-11500  $\mu\text{m}$ , 0-300 mm/h), a check for losses due to leakage of the shutter or evaporation (0.1 mm over the last hour) and calculates the intensities. A fatal status level "K" is reported when the maximum level is exceeded.

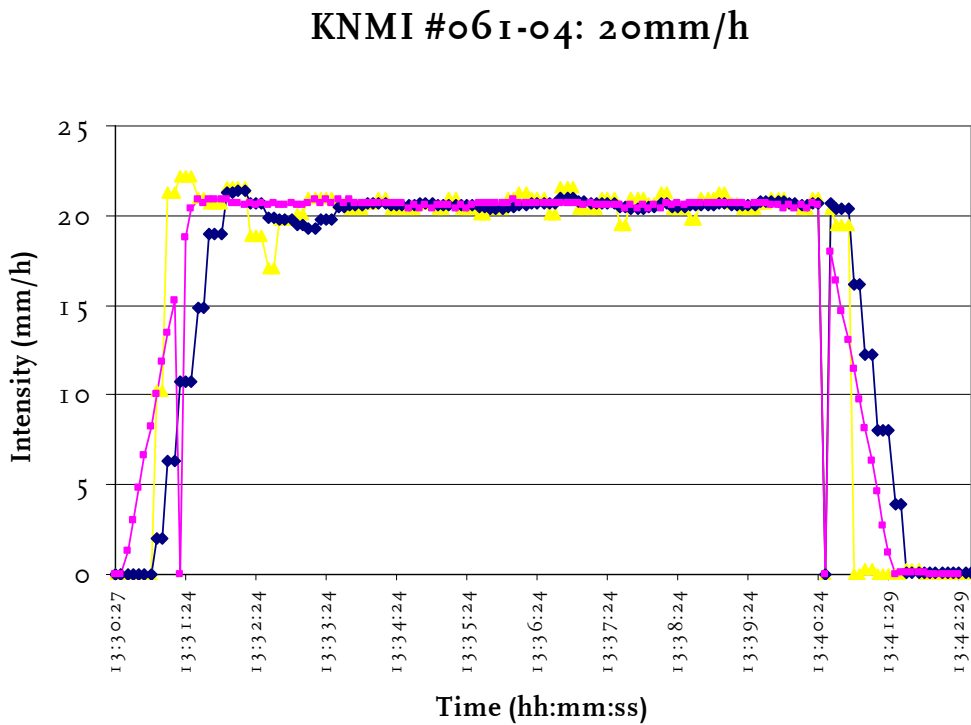
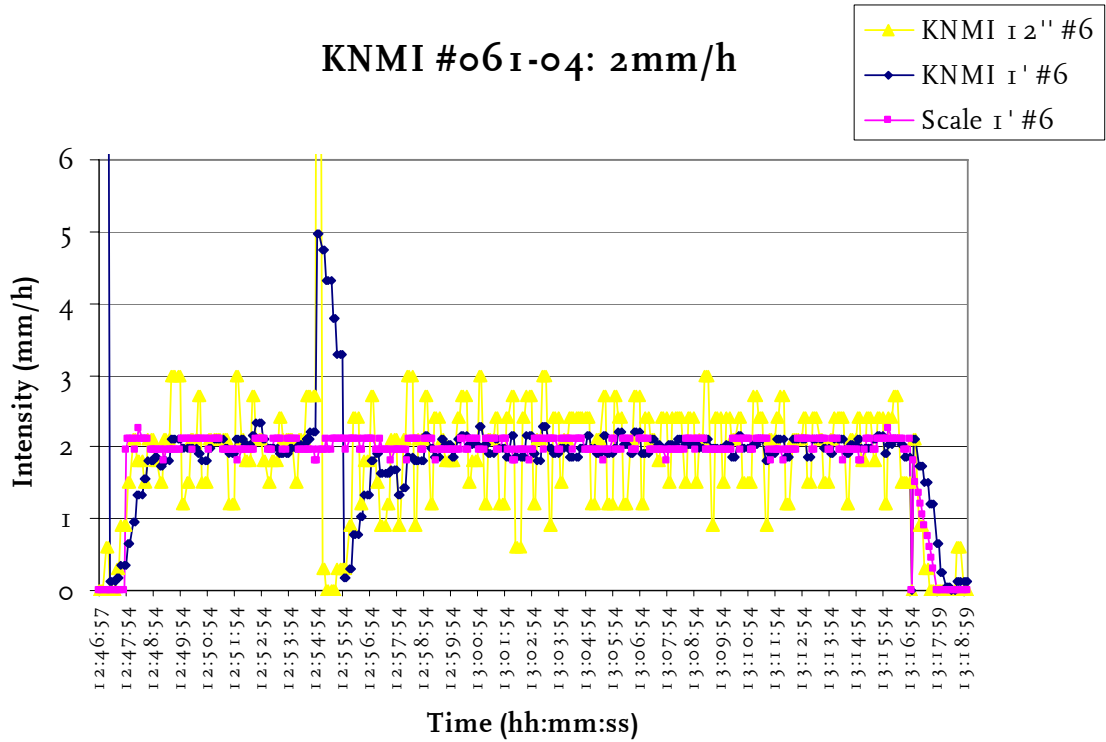

Figure 60: Time series of the running 1-minute averaged reference intensity and the corresponding 1-minute and 12-second intensity from the Neerslagmeter measurements of run 6 for instrument 061-04.

Timing of emptying events at various intensities showed the emptying takes about 16 s at 2 mm/h up to about 20 s at 270 mm/h. The results for 90 mm/h show an underestimation of the intensity due to emptying of the sensor in the second minute of the run. In the first 12 seconds interval the previous intensity is persisted and is therefore not visible in the time series, but in the second interval the intensity is underestimated. The reason for this is that flushing stopped after about 17 seconds and water level was reset one second later so that only 7 seconds remained for accumulation of precipitation. The fact that water is not accumulated over the full 12-second interval is not taken into account by the sensor interface and hence results in an underestimation of the intensity. The emptying in event at 170 mm/h shows a different behavior since an underestimation can be observed in 2 12-second samples. In the first interval the sensor interface persists the intensity, but the artificial internal water level is truncated to the maximum level and hence the intensity is underestimated. The underestimation of the second sample is again caused by the partial usage of the 12-second interval for accumulation of precipitation after emptying. The difference between the level of emptying and the maximum level is 0.5 mm and hence at intensities above 75 mm/h the above behavior during emptying can occur (at least 0.5 mm in 24 s). The emptying event at 262 mm/h shows another behavior. In this case the water level already exceeds the maximum level before emptying starts and a fatal status K is reported. This can occur when at least 0.5 mm is added to the water level in 12 s, i.e. at intensities above 150 mm/h. In this case 1 sample unavailable because of the fatal error, the next sample gives a 0 mm/h since the previous intensity cannot be persisted and the third sample shows the underestimation by the partial usage of the 12-second interval for accumulation of precipitation after emptying.

Figure 60 shows time series of instrument 061-04 for run 6. This run was performed in order to get emptying during low reference intensities, i.e. the water level in the sensor was manually increased to just underneath 11 cm at the start of the intensity run. The time series at 2 mm/h shows that the intensity is persisted at 2.7 mm/h during emptying. After emptying the compensation for hysteresis of 0.06 mm (18 mm/h on 12 second interval) by the sensor interface is evident as well as the low intensities that result from the hysteresis. The compensation for hysteresis is slightly too large for this instrument. The effect of hysteresis is less pronounced at 20 mm/h. First the addition of the compensation for hysteresis is masked by the underestimation resulting from the partial usage of the 12-second interval for accumulation of precipitation after emptying. The next sample shows the underestimation that is a result of the hysteresis.

Comments related to the Neerslagmeter are:

- The tests for this instrument were performed with a sample interval of 5 s.
- The evaporation of the reservoir on the unused scale was measured for all intensities and ranged between 0.04 and 0.11 mm/h. This measured evaporation value is compensated in the data analysis.
- The software version of the sensor interface is 2.0.
- The persistence of intensity during emptying is not correctly taken into account by the sensor interface since it is limited to by the maximum water level.
- The intensity derived after emptying does not take into account that only a part of 12-second interval was used for the accumulation of precipitation.

- The maximum intensity is 150 mm/h because at higher intensities the upper limit of the water level can be exceeded before emptying occurs.
- The sensor does not indicate when emptying, and hence persistence of intensity, occurs.

## 4. Summary, conclusions and recommendations

### 4.1. Summary

A summary of the results of the laboratory test at KNMI is given in Figure 61 and Figure 62. Figure 61 shows the power law fits to the averaged measured intensity as a function of the reference intensity, whereas Figure 62 shows the second order polynomials fitted to the averaged relative errors as a function of the reference intensity. The fit is performed on the averaged results of 2 instruments combined in those cases (all sensors, except AP23 and H-340SDI) where 2 instruments were available. The upper panels show the results for the range up to 800 mm/h and the lower panels zoom in on the 0-200 mm/h range. It should be noted that in some cases the fitted second order polynomials does not capture all the details of the actual the averaged relative errors as a function of intensity and the fit can deviate significantly at observed values at some intensities. However, the smoothed result of the second order polynomial fit makes the finding and following of the curve for each of the 20 sensors easier. The second order polynomial fits to the averaged errors give more details than the power law fits, especially at low intensities. Furthermore, the agreement with the measured values is generally better for polynomial than for the power law fit. The power law fits are included so that they may be compared to the corresponding curves presented in the WMO final report. In this report the summary of the results is based on the second order polynomial fits of the averaged relative errors. For the details of the results for each sensor the reader is referred to the appropriate part in the results and discussion section and the corresponding appendix.

The fitted errors for all sensors are shown in Figure 62, where the upper panel shows the results for the range up to 800 mm/h and the lower panel zooms in on the 0-200 mm/h range and the WMO limits. Line and marker types indicate the different types of instruments. The thick dashed lines denote the uncorrected tipping bucket rain gauges (AP23, TBRG Mk2, 1518H3 and 100000E). All uncorrected tipping bucket rain gauges show their characteristic underestimation and do not fall within the WMO limits of  $\pm 5\%$ . It is also clear that of the tipping bucket rain gauges with mechanical correction (Rimco 7499, TB-3 and UM7525), denoted by the thin dashed line with diamond markers, only the TB-3 gives results within the WMO limits. The tipping bucket rain gauges with software correction (MR3H-FC, PMB2, R102, WMB01 and H-340SDI), denoted by the thin solid lines, generally give results within the WMO limits, except the MR3H-FC and H-340SDI sensors, although the other three sensor still show some intensity dependency. Square markers denote the water level sensors (Alluvion 100, Nilometre and KNMI Neerslagmeter), of which the Nilometre and KNMI show good agreement with hardly any intensity dependence, but with an offset, whereas the Alluvion 100 behaves like an uncorrected tipping bucket gauge. The latter is not a coincidence since the Alluvion has 6 discrete water levels that generate tips while the loss during siphoning might account for the underestimation. The weighing gauges (MRW500, VRG101, Pluvio 250, T-200B and TRwS), denoted by the asterisk, show good agreement with the reference, but they all show a small dependency with intensity. This is generally caused by the polynomial fit that tries to compensate for a deviation often at 2 mm/h.

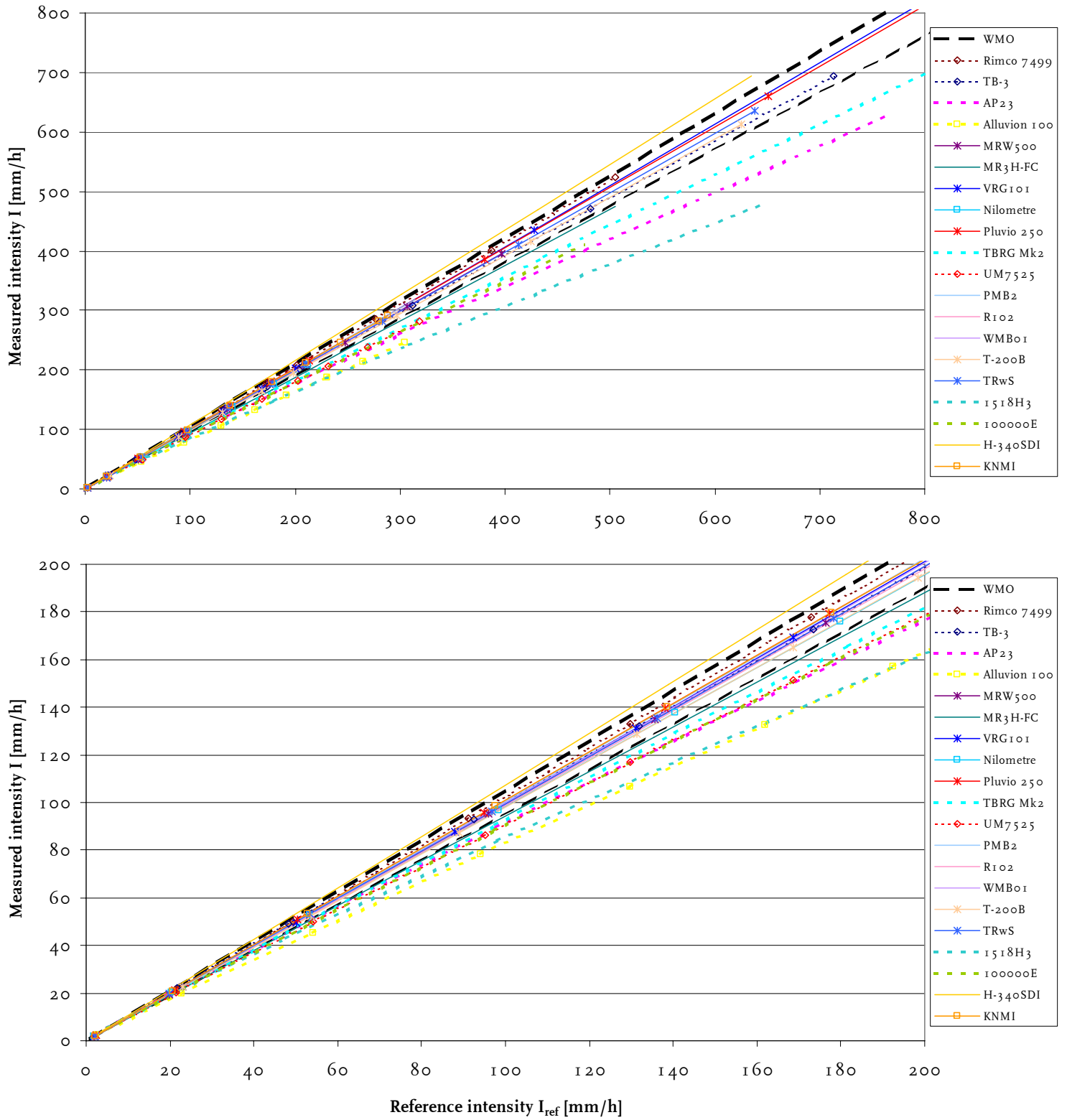

Figure 61: Power law fits to the averaged measured intensities of the tested rain gauges as a function of the reference intensity.

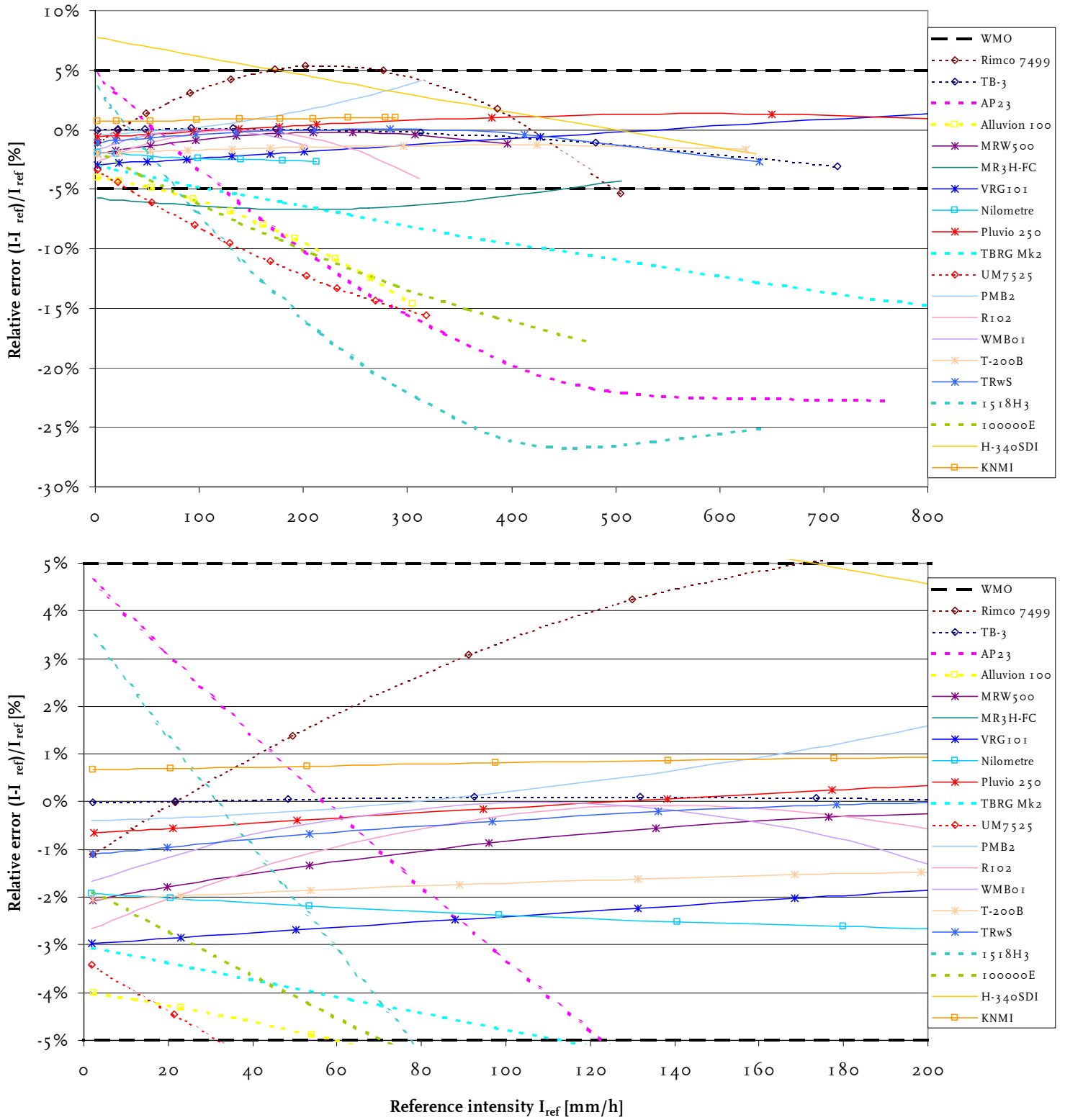

Figure 62: Second order polynomial fits to the averaged relative errors of the tested rain gauges as a function of the reference intensity.

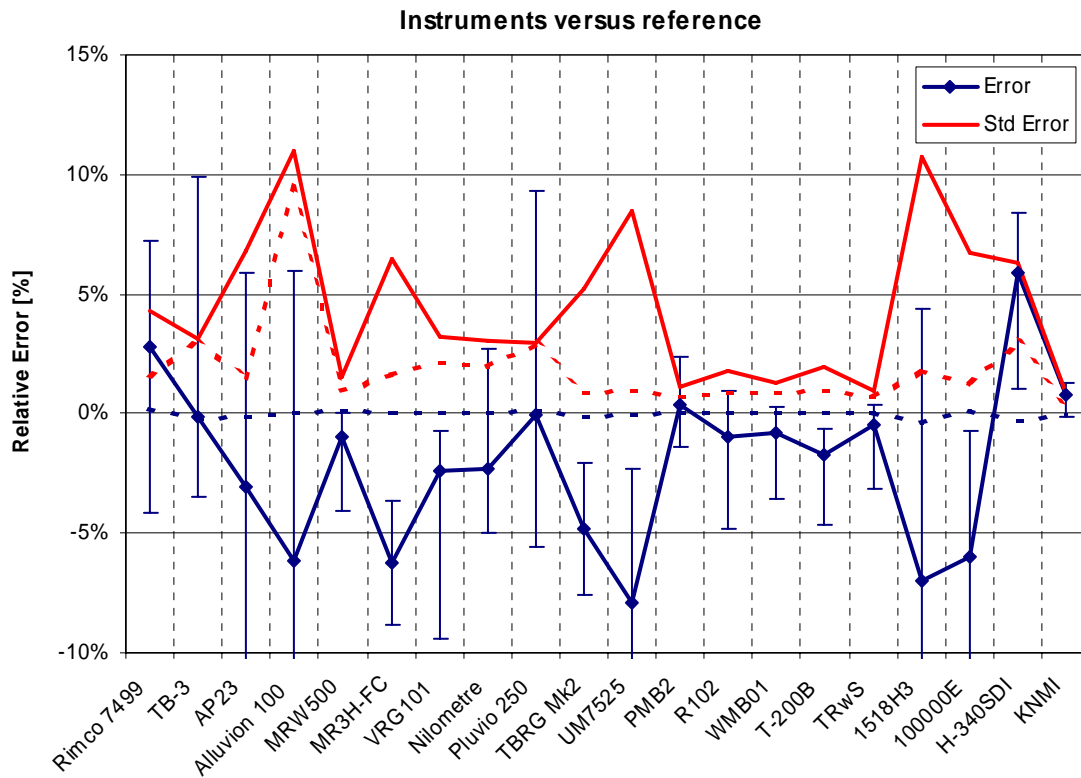

Figure 63: Averaged error for each sensor for all instruments and intensities between 2-200 mm/h. The extremes (error bars) and the standard error (red) are also indicated. The dashed curves show the similar results after correction with the second order polynomial fit.

A summary of the sensor results that is more concise and does not involve fits to the results is given in Figure 63. This figure shows the averaged error for each sensor and the extremes. The average and extremes have been calculated for both instruments and for all intensities between 2-200 mm/h. The intensity range is limited in order to make the results of the sensors better comparable. The standard error for each sensor is given in red. The sensors that fully comply with the WMO limits for the intensity range of 2-200 mm/h, i.e. the extremes are within  $\pm 5\%$ , are the MRW500, Nilometre, PMB2, R102, WMB01, T-220B, TRwS and the KNMI Neerslagmeter (after correction for an error during emptying). Of the other sensors, the Rimco 7499, TB-3, VRG101 and Pluvio 250 (and the uncorrected KNMI Neerslagmeter) have the average and standard error within  $\pm 5\%$  of the reference. The reasons why the extremes for these sensors not meet the WMO limits are the following. The error of the Rimco 7499 sensor has an intensity dependence that causes errors larger than 5% at 200 mm/h (and below  $-5\%$  for the uncorrected KNMI Neerslagmeter). The TB-3 and VRG101 sensors give over- and underestimations at 2 mm/h, respectively. One Pluvio 250 instrument gives a too large underestimation at 2 mm/h, whereas the other instrument has an overestimation at 90 mm/h due to the delay. The dashed lines show the errors after a correction by the fitted second order polynomial has been applied. The averaged error is for all sensors very

small (within 0.4 %) and the standard error also reduces for many sensors, especially the tipping bucket rain gauges without correction.

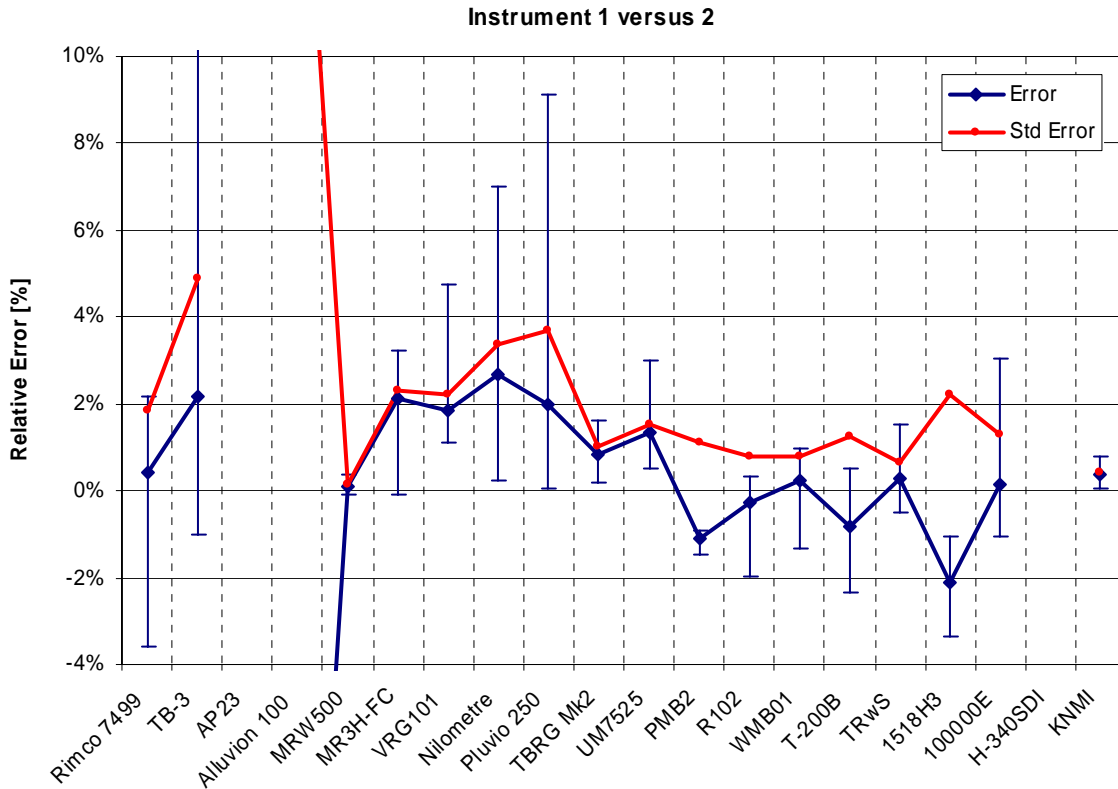

Figure 64: Averaged error for all intensities between 2-200 mm/h between the 2 instruments for all sensors. The extremes (error bars) and the standard error (red) are also indicated.

In the above comparison the results of uncorrected and corrected sensors have been compared. However, an uncorrected sensor can have such a behavior that it gives good results after a suitable correction. For that purpose it is investigated whether (i) the behavior of the sensors is consistent, i.e. the differences between the 2 instruments of each sensor are small, and (ii) the error curves are smooth compared to the second order polynomial fit. The consistency between 2 instruments of the same sensor is shown in Figure 64. The averaged error and extremes for the 2 instruments of each sensor are reported for all intensities between 2-200 mm/h. From the figure it can be seen that the MRW500, TBRG MK2, PMB2, R102, WMB01, TRwS and KNMI Neerslagmeter (uncorrected as well as corrected) instruments fully agree within  $\pm 2$  %. The MR3H-FC, VRG101, UM7525, T-200B and 1518H3 instruments have an offset, but otherwise would differ within a range of  $\pm 2$  %. This offset is very large ( $-18$  %) for the Alluvion 100 sensor. The Rimco 7499, TB-3, Nilometre, Pluvio 250 and 100000E do not fall within the  $\pm 2$  % range due to isolated larger errors at 20, 2, 2, 90, 20 mm/h, respectively. The AP23 and H340-SDI sensors could not be checked for consistency since only 1 instrument was available for the test. The smoothness of the fitted curves is given by the parameters of the second order polynomial fit to the averaged errors. The parameters for the polynomial

fit to the averaged errors for intensities between 2-200 mm/h are given in Figure 65 for each sensor. Each parameter has been multiplied by a fixed factor so that the variation of each parameter per sensor can easily be compared. The parameter  $c$  is the offset of the error and is not considered further. The linear slope and curvature are of the fit are expressed by the parameters  $b$  and  $a$ , respectively. Large values of  $a$  indicate a large curvature, but that does not necessarily mean that the sensor results are not good. The large curvature for R102 and WMB01 are caused by the relatively large underestimation of the sensor results at 2 mm/h, which the polynomial tries to capture, although the errors themselves are not large. In order to compensate for this effect another parameter has been devised. The combination of the information on the slope and curvature of the fit and the standard error between the 2 instruments of each sensor was performed by some trails, but the choice was rather arbitrary. The parameter considered is  $(ABS(a) \times 10^3 + ABS(b)) \times (StdEr)^2 \times 10^7$ , which is again scaled so that it can easily be read in the figure. This dimensionless positive quality parameter places the results of MRW500, VRG101, TBRG Mk2, PMB2, T-200B, TRwS and KNMI Neerslagmeter below 1, whereas MR3H-FC, Nilometre, Pluvio 250, R102, WMB01 and 100000E are below 2. The quality parameter has not been derived for the single AP23 and H-340SDI instruments and for the Alluvion 100 sensor the value of the quality parameter is 265. It may be surprising that the TBRG Mk2 sensor is now rated among the best class of sensors, but the error curves of this uncorrected tipping bucket sensor are quite smooth the results of both instruments are close, i.e. optimal conditions for correction of data.

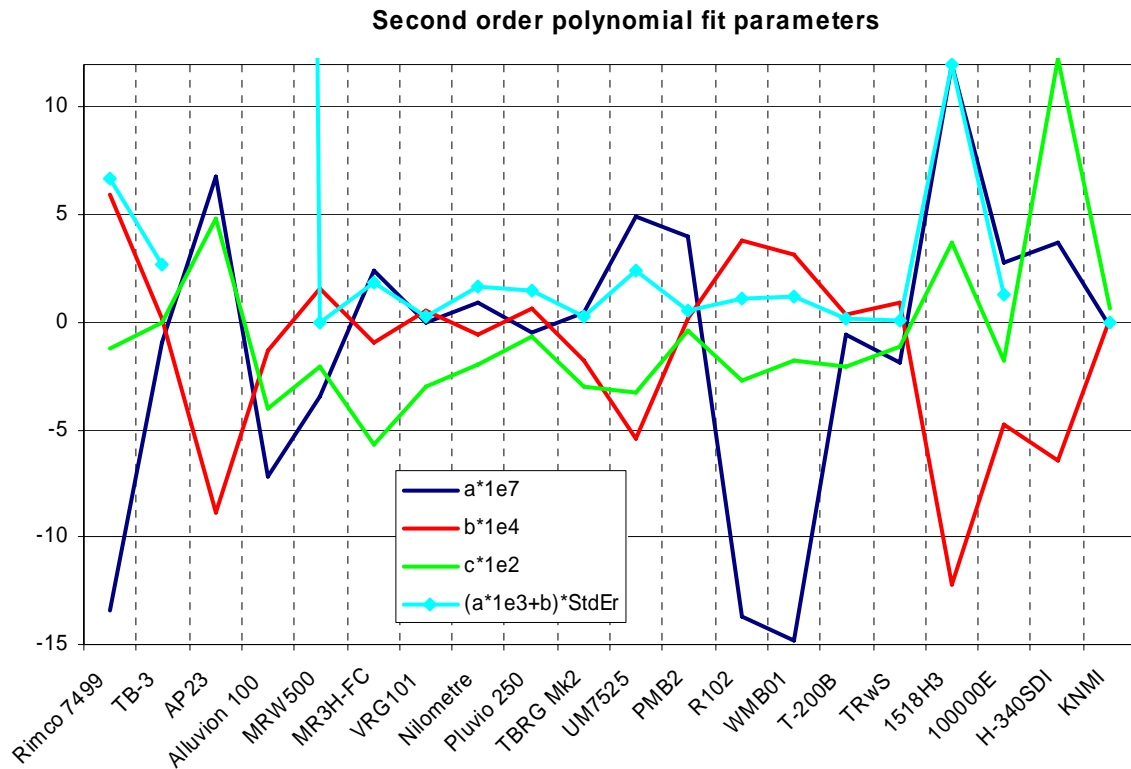

Figure 65: Overview of the parameters of the second order polynomial fit to the averaged errors for intensities between 2-200 mm/h for each sensor.

## **4.2. Conclusions and recommendations**

This report gives results for 20 different types of catchment rainfall intensity gauges. It is not possible to select a best sensor, which is acceptable for all user applications. Each user must specify the requirements and needs to check whether any of the sensors meets these criteria. Furthermore the ambient conditions, maintenance aspects, costs etc. must be taken into account as well as the limitations regarding the setup and acquisition system. Furthermore, it should be noted that the results given in this report were obtained in laboratory conditions. When operating the sensor in the field other error sources like evaporation, wetting, out-splashing, wind induced errors, solid precipitation etc. must be taken into account during the selection. Maintenance issues regarding maintenance interval of cleaning or emptying, susceptibility to malfunction, robustness etc. put further constraints. These aspects will be considered in the oncoming WMO field test of rainfall intensity gauges. At KNMI field tests have been performed recently with the KNMI Neerslagmeter and the Pluvio 250. As mentioned in the report the test results of the Pluvio 250 are very good, except for the large delay of the sensor. However, during the field test it proved necessary to introduce such a filter in order to overcome faulty precipitation events. Depending on the user application the results of the sensor might be acceptable, e.g. the total precipitation amounts are accurate and climatological users do not mind the delay, even for intensity measurements the delay itself might not be the problem, but the fact the sensor software tries to compensate for the delay such that the reported 1-minute intensity has no direct relation to the 1-minute intensity that actually occurred at some time before.

A selection of suitable sensors is performed next. For that purpose the following requirements are set, which are roughly based on the current requirements for precipitation measurements at KNMI. The sensor should naturally meet the WMO accuracy criteria of  $\pm 5\%$ , but this may be obtained by performing a correction to the data, although preference is given to sensors that measure intrinsically accurately. Since  $\pm 5\%$  should be the accuracy of the measurement in the field, an accuracy of  $\pm 2\%$  is required for the laboratory tests (for that purpose the number of cases is computed where the sensor results differ more than  $\pm 2\%$  from the reference and up to 5 such events is acceptable). The sensor should be consistent within  $\pm 2\%$  (the maximum absolute relative error between the 2 instruments is considered for this). The  $\pm 2\%$  accuracy should be met over the full operational intensity range, which is 2-200 mm/h. The resolution of the sensor should be better than 0.1 mm (in fact KNMI requires a resolution of at least 0.01 mm/h, but that would limit the choice too much). The delay should be less than 3 minutes (again KNMI and WMO requires a delay of maximally 1 minute but in order to extend the choice the delay is set equivalent to a resolution of 0.1 mm at 2 mm/h). Low intensities occur quite often in the Netherlands and therefore the accuracy of the 1-minute averaged intensity at low intensities is required (standard deviation of variability of intensity or the time between tips should be within 15%, respectively). The suitability of correction is considered by requiring that the quality parameter introduced above is below 1. Further criteria such as the costs (e.g. a tipping bucket rain gauge can be considered cheap - disregarding any data-logger - while all weighing or water level gauges can be considered expensive), maintenance (e.g. any sensor requiring regular manual attendance such as emptying can be marked as high maintenance although a local person could take care of

this), robustness and availability (e.g. a sensor with some malfunction such as continuous siphoning or a tipping balance that got stuck during the tests can be marked as too frail), documentation etc. are not considered here.

Table 5: Performance of all sensors according to the criteria set as an example. Shaded cells indicate requirements that have not been met and the last column gives the total score for the best sensors (lower number is higher score).

No.	Sensor	Range within WMO limits (# events outside $\pm 2\%$ )	Sensitivity [mm] (resolution within 0.1 mm)	Delay / Resolution (within 3 min at 2 mm/h)	Reproducibility (standard error within 2%)	Variability (standard deviation < 15%)	Correction Quality parameter	Score
1	Rimco 7499	12	0.3	-	3.6	36	6.7	-
2	TB-3	4	0.4	-	12.5	41	2.7	-
3	AP23	12	0.1	-	-	6	-	-
4	Alluvion 100	11	0.2	-	19.5	46	265.3	-
5	MRW500	2	0.1	20 s	0.4	59	0.0	1
6	MR3H-FC	14	0.1	-	3.2	9	1.8	1½*
7	VRG101	8	0.01	7 min	4.7	57	0.3	3
8	Nilometre	9	0.01	2 min	7.0	86	1.6	2½
9	Pluvio 250	3	0.01	8 min	9.1	13	1.4	2*
10	TBRG Mk2	14	0.5	-	1.6	2	0.2	1½*
11	UM7525	14	0.2	-	3.0	5	2.4	3
12	PMB2	2	0.2	-	1.5	2	0.5	1
13	R102	3	0.2	-	2.0	3	1.1	1
14	WMB01	2	1.0	-	1.3	4	1.2	1½*
15	T-200B	3	0.01	20 s	2.3	20	0.1	2
16	TRwS	1	0.001	3 min	1.5	9	0.1	0
17	1518H3	11	0.1	-	3.3	4	12.0	-
18	100000E	13	0.2	-	3.1	4	1.3	3
19	H-340SDI	12	0.254	-	-	8	-	-
20	Neerslagmeter	0	0.006	36 s	0.8	12	0.0	0

Table 5 has been completed using the requirements given above. Shaded cells indicate requirement that have not been met. It is clear that only the TRwS and the corrected KNMI Neerslagmeter meet all criteria. However, the KNMI sensor needs to correct the faulty results during emptying. Emptying has to be performed manually for the TRwS and furthermore it has to be verified in the field that the high resolution does not caused faulty precipitation events. The PMB2 and R102 do not meet the requirements for the

resolution. Both Italian sensors have similar characteristics, but the PMB2 sensor performs slightly better. Furthermore, the correction applied by the R102 sensor by introducing artificial tips results in fluctuations of the “instantaneous” intensity and since the raw tips are not readily available the raw results cannot be stored for future improvements. The MRW500 is also a good sensor that only showed too much variability at low intensities, and the results will be affected when the automated emptying needs to be performed during precipitation. When the resolution is not a real issue, then the TBRG Mk2, with a correction, and maybe even the WMB01 sensor are good options. These sensors are also capable to measure up to 2000 mm/h. The VRG101 can also measure up to 2000 mm/h, but then the delay, reproducibility and the variability at 2 mm/h are not so good. The Pluvio 250 can measure up to 1200 mm/h and is an excellent choice when the delay is no issue. However, for the Netherlands these high rainfall intensities are not relevant.

Some recommendations concerning the test setup and data analysis are:

- The time resolution of the data-acquisition should be higher particularly for the acquisition of the pulse output. A higher resolution allows a better evaluation of the variability of the time between tips. In this study a resolution of 10 seconds - and later 5 seconds - is used, but a resolution of at least 0.5 second is required. A higher temporal resolution also has a positive effect on the uncertainty and/or duration of the test.
- The effect of evaporation of the reservoir should be minimized by using a suitable cover. The measurement and compensation for evaporation as applied during these tests still has a noticeable uncertainty at low precipitation intensities.
- The uncertainty and duration of the test both benefit from a scale with a resolution of 0.01 g instead of 0.1 g.
- The test procedure should include suitable delays before and after each intensity run in order to be able to check the response and the total precipitation amount of the instrument for each reference intensity. Such a procedure was only used during the final phase of the test.
- The data analysis using Excel turned out to be very time consuming and susceptible to errors. A separate file was used for each instrument. This is caused by a missing overview of the formulae used in a worksheet and the required homogenization of the processing.

### **4.3. Conclusions KNMI Neerslagmeter**

The test confirmed that the sensor characteristics of the KNMI Neerslagmeter can hardly be reproduced by any commercially available sensor. The accuracy of the KNMI Neerslagmeter is a good, but the software introduces errors during emptying. The errors are discussed in detail in section 3.20. The errors are caused by the upper limit of the water level in the sensor when assuming constant intensity rates during emptying. The upper limit can then be exceeded, which results in truncation of the water level and an underestimation of the rainfall amount or even an error status. Furthermore, the precipitation amount collected directly after emptying is converted into intensity by assuming a time interval of 12 seconds, while in fact the precipitation was collected over a period less than 12 seconds, resulting in another underestimation of the reported

intensity. These errors can be fixed in the software of the sensor interface. Furthermore, the sensor interface should give a warning status message when the reported intensity is not actually measured during emptying.

After the above-mentioned software upgrade the sensor still assumes that the precipitation rate is constant during emptying. The constant flow assumption is not valid in the field and hence it must be investigated during the next upgrade of the Neerslagmeter whether it is possible to introduce another valve between the collecting funnel and the reservoir that can be closed before emptying so that water is temporarily stored in the funnel during emptying of the reservoir. After emptying the stored water is released into the reservoir and can be measured.

## 5. References and acknowledgements

### 5.1. References

In this section only a small selection of references is given. Many references are listed in the final report of the WMO Laboratory Intercomparison of Rainfall Intensity Gauges (2006). For more information on the sensors involved in this test the reader is referred to the documentation of the manufacturer. The list below only contains information references regarding the KNMI Neerslagmeter and laboratory and field tests performed at KNMI.

- Bijma, J.R.: XR2-SIAM Precipitation (in Dutch), Version 1.0, Instrumental Department, KNMI, De Bilt, 1998.
- Kuik, F.: Precipitation Research 1998 (in Dutch), Internal Report **IR 2001-01**, KNMI, De Bilt, 2001.
- Lanza, L. et al.: WMO Laboratory Intercomparison of Rainfall Intensity Gauges, Final report, WMO, Geneva, 2006.
- Muller, S.H. and Van Londen, A.: On the Evaluation of Rain Gauges, for example the Thies Rain Gauge and the Electrical KNMI Rain Gauge (in Dutch), Scientific Report **WR 83-16**, KNMI, De Bilt, 1983.
- Wauben, W.M.F.: Precipitation amount and intensity measurements using a windscreen, Technical Report **TR 2004-262**, KNMI, De Bilt, 2004.
- Wauben, W.M.F.: Precipitation amount and intensity measurements with the Ott Pluvio, Technical Report **TR 2005-270**, KNMI, De Bilt, 2004.
- WMO: Guide to Meteorological Instruments and Methods of Observation, Sixth edition, WMO-No. **8**, WMO, Geneva, 1996.
- WMO: WMO-CIMO Expert Meeting on Rainfall Intensity Measurements, Final Report, 23-25 April 2001, Bratislava, Slovakia, 2001.

### 5.2. Acknowledgements

It is a pleasure to thank the KNMI staff involved in this laboratory intercomparison of rainfall intensity gauges, in particular Alexander Mazee (for performing the tests runs of the first sensor batch at KNMI and most of the software development); Frans Renes and Arjan Kramer (for performing the tests runs of the second the third sensor batch, respectively), André van Londen (for sharing his experience regarding calibration of precipitation rain gauges) and Jitze van der Meulen (for detailed comments on an incomplete draft version of this report). Furthermore, stimulating discussions and feedback on sensor results from other laboratories within the ET/IOC are acknowledged.

## Appendix 1: Rimco 7499

Overview of the sensor results derived from tips versus the reference and between the 2 instruments. The coefficients of the polynomial fit and the power law fit are reported and the standard error after correction.

Parameter description	Sensor		
	84639	84642	Combined
Average within WMO range (mm/h)	2-90, 280-500	2-170, 280-500	-
Standard error sensor 1 versus 2	-	-	1.72%
R <sup>2</sup> measured versus reference	0.9973	0.9972	0.9971
Standard error measured versus reference	4.20%	3.81%	4.01%
Polynomial fit to error a	-1.42E-06	-1.25E-06	-1.34E-06
Error in a	2.04E-07	2.43E-07	1.53E-07
Polynomial fit to error b	0.0007	0.0005	0.0006
Error in b	0.0001	0.0001	0.0001
Polynomial fit to error c	-0.015	-0.009	-0.012
Error in c	0.010	0.012	0.007
Polynomial fit to error R <sup>2</sup>	0.8760	0.8152	0.8285
Standard error after correction	1.20%	1.49%	1.43%
Power law fit a	0.985	0.989	0.987
Error in a	0.035	0.037	0.024
Power law fit b	1.006	1.006	1.007
Error in b	0.007	0.008	0.005
Power law fit R <sup>2</sup>	0.9970	0.9970	0.9968
Standard error measured versus power law	3.13%	3.28%	3.24%

Summary of the average and standard deviation of the reference intensities and the time interval between consecutive tips for all 5 tests.

Reference intensity [mm/h]		84639 tip interval [s]		Reference intensity [mm/h]		84642 tip interval [s]	
Average	Std. Dev.	Average	Std. Dev.	Average	Std. Dev.	Average	Std. Dev.
2.05	0.46	375.08	172.60	2.18	0.43	365.30	103.00
21.05	1.00	36.44	13.11	21.44	0.53	36.00	12.69
49.30	1.26	15.38	5.42	49.30	0.71	15.43	5.10
90.50	2.54	8.14	2.43	91.41	3.92	8.21	2.56
130.54	0.98	5.99	2.41	130.92	2.10	6.06	2.47
173.51	1.19	4.17	1.15	173.34	2.90	4.28	1.31
201.69	1.47	3.44	0.66	203.68	2.99	3.49	0.74
280.03	1.84	2.48	0.11	275.95	6.85	2.54	0.21
376.01	2.96	1.90	0.15	388.10	7.10	1.88	0.16
497.57	36.15*	1.53	0.42*	508.79	11.04	1.50	0.11

\* Run 3 at 500 mm/h ran out of water and resulted in a large standard deviation.

1			2			3			4			5			Tips	
Rimco 7499			Rimco 7499			Rimco 7499			Rimco 7499			Rimco 7499				
run	#1		run	#2		run	#3		run	#4		run	#5			
Ser.nr	84639		Ser.nr	84639		Ser.nr	84639		Ser.nr	84639		Ser.nr	84639			
Tamb	21.3		Tamb	22.3		Tamb	21.6		Tamb	22.2		Tamb	21.9			
Twater	18.0		Twater	18.8		Twater	18.2		Twater	18.8		Twater	19.0			
RelHum	24.0		RelHum	24.0		RelHum	21.0		RelHum	23.0		RelHum	35.0			
QNH	1021		QNH	1021		QNH	1021		QNH	1023		QNH	1004			
date	20/12/04		date	20/12/04		date	21/12/04		date	21/12/04		date	23/12/04			
time	08:31		time	12:09		time	08:05		time	12:27		time	08:03			
@precip.	measured		@precip.	measured		@precip.	measured		@precip.	measured		@precip.	measured		@precip.	result
mm/h	deviation		mm/h	deviation		mm/h	deviation		mm/h	deviation		mm/h	deviation		mm/h	deviation
2	2.2	-4.2% I	2.2	4.9% O		1.9	-0.7% I		2.0	-5.6% O		1.9	-1.2% I		2.0	-2.0% I
20	21.5	-0.8% I	22.1	-1.3% I		19.5	-7.6% O		21.1	3.7% O		20.9	-3.8% I		21.5	-2.0% I
50	50.2	0.8% I	51.0	-0.7% O		48.8	5.8% O		48.3	4.8% I		48.1	2.9% I		48.9	2.8% I
90	89.9	4.5% I	90.5	2.0% O		90.9	3.9% I		91.4	4.2% I		90.5	7.2% O		90.7	4.2% I
130	129.8	5.0% I	130.4	5.1% I		130.8	4.7% O		131.0	5.9% I		130.7	6.6% O		130.4	5.3% I
170	172.3	5.1% O	173.5	5.7% I		173.5	5.8% I		174.5	5.6% I		174.0	8.2% O		173.8	5.7% I
200	200.2	8.3% O	201.7	5.9% O		201.7	7.1% I		202.6	7.4% I		202.3	7.2% I		202.2	7.2% I
271	278.7	4.0% I	279.7	4.1% I		279.6	4.4% O		280.9	3.9% I		281.5	3.7% O		279.8	4.0% I
368	374.4	0.7% O	376.1	1.9% I		374.6	1.0% I		377.7	1.7% I		377.4	2.2% O		376.1	1.5% I
500	497.5	-3.1% I	500.6	-2.7% I		466.2	1.5% O		502.9	-7.3% O		502.4	-4.3% I		500.2	-3.4% I
Tamb	22.3		Tamb	22.5		Tamb	22.2		Tamb	22.5		Tamb	23.0			
Twater	18.8		Twater	19.3		Twater	19.2		Twater	19.4		Twater	19.0			
RelHum	24.0		RelHum	24.0		RelHum	22.0		RelHum	23.0		RelHum	35.0			
QNH	1021		QNH	1020		QNH	1023		QNH	1023		QNH	1003			
date	20/12/04		date	20/12/04		date	21/12/04		date	21/12/04		date	23/12/04			
time	12:07		time	15:46		time	12:23		time	16:07		time	11:41			

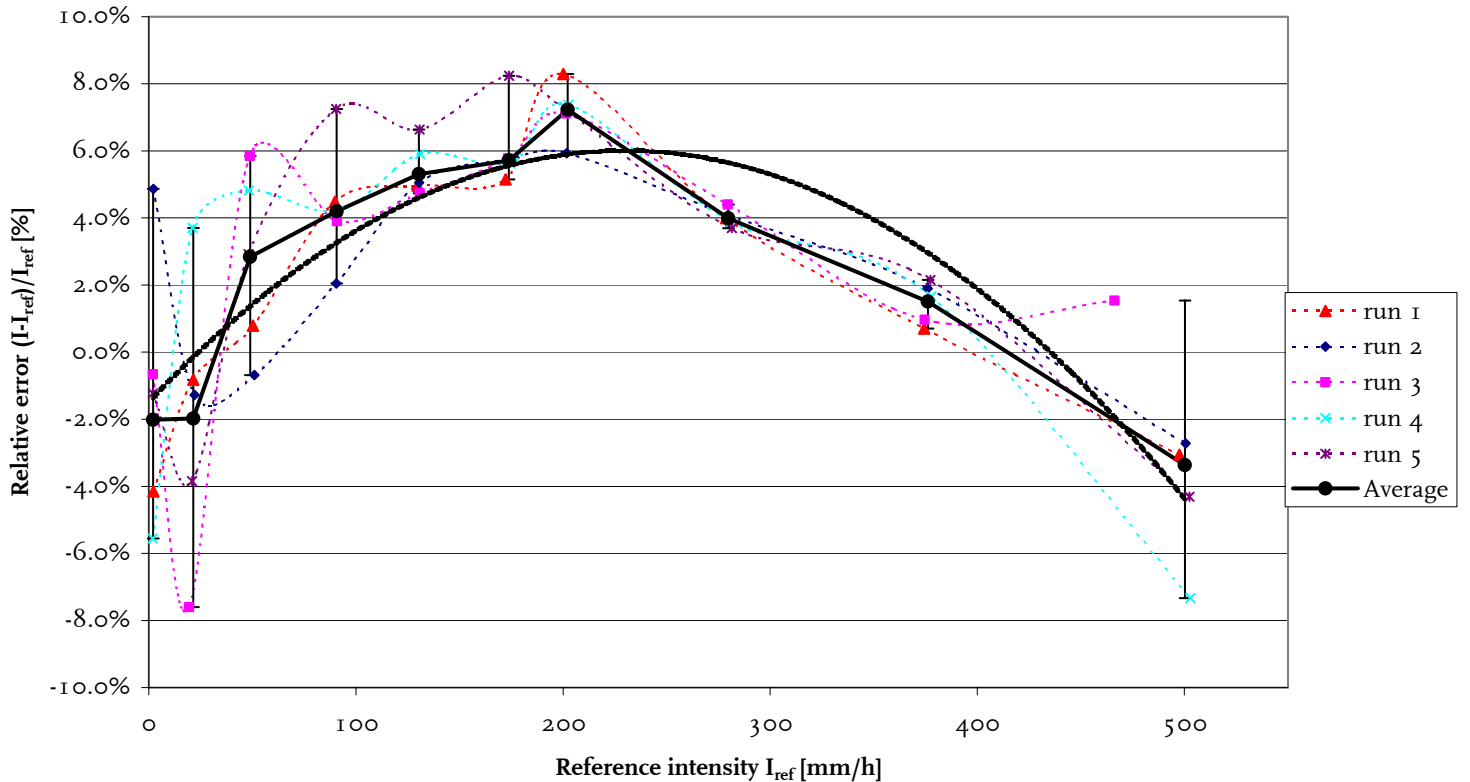

1			2			3			4			5			Tips		
Rimco 7499			Rimco 7499			Rimco 7499			Rimco 7499			Rimco 7499					
run	#6		run	#2		run	#3		run	#4		run	#5				
Ser.nr	84642		Ser.nr	84642		Ser.nr	84642		Ser.nr	84642		Ser.nr	84642				
Tamb	21.8		Tamb	22.1	inullen	Tamb	21.7		Tamb	21.2		Tamb	22.4				
Twater	18.8		Twater	19.8		Twater	18.2		Twater	18.2		Twater	19.3				
RelHum	28.0		RelHum	31.0		RelHum	26.0		RelHum	26.0		RelHum	26.0				
QNH	1024		QNH	1001		QNH	1018		QNH	998		QNH	999				
date	29/12/04		date	24/12/04		date	27/12/04		date	28/12/04		date	28/12/04				
time	12:40		time	13:15		time	11:28		time	08:03		time	12:35				
@precip.	measured		@precip.	measured		@precip.	measured		@precip.	measured		@precip.	measured		@precip.	result	
mm/h	deviation		mm/h	deviation		mm/h	deviation		mm/h	deviation		mm/h	deviation		mm/h	deviation	
2	2.3	-1.6%	I	2.0	-8.4%	O	2.2	-6.5%	I	2.2	-0.5%	O	2.3	-4.4%	I	2.2	-4.2%
20	21.4	4.9%	O	21.2	-1.8%	O	21.5	0.6%	I	21.5	1.7%	I	21.6	2.5%	I	21.5	1.6%
50	49.2	3.9%	I	48.6	-2.8%	O	49.7	2.3%	I	49.2	3.5%	I	49.8	4.8%	O	49.4	3.2%
90	93.4	2.3%	O	91.7	3.0%	I	91.5	3.2%	I	90.5	3.6%	I	90.5	4.3%	O	91.2	3.2%
130	133.8	3.0%	O	131.8	3.9%	I	131.3	5.7%	O	129.0	4.4%	I	128.7	4.7%	I	129.9	4.3%
170	177.4	4.3%	O	175.1	4.8%	I	173.3	5.4%	I	170.7	4.3%	I	170.1	5.6%	O	173.0	4.8%
200	208.8	3.9%	O	204.1	4.8%	I	203.9	6.7%	O	200.9	5.3%	I	201.4	5.7%	I	202.1	5.3%
271	282.6	2.2%	O	283.6	2.9%	I	275.5	2.8%	I	267.5	4.8%	O	270.4	3.6%	I	276.5	3.1%
368	402.3	-2.2%	O	379.5	0.0%	O	386.0	-0.5%	I	386.6	-0.7%	I	387.9	-0.4%	I	386.8	-0.5%
500	529.5	-7.5%	O	505.3	-4.9%	I	506.9	-5.2%	I	498.9	-3.8%	O	503.0	-4.7%	I	505.1	-4.9%
Tamb	22.9		Tamb	23.0		Tamb	22.5		Tamb	22.4		Tamb	22.8				
Twater	19.8		Twater	20.2		Twater	19.2		Twater	19.4		Twater	19.8				
RelHum	28.0		RelHum	30.0		RelHum	25.0		RelHum	26.0		RelHum	26.0				
QNH	1026		QNH	997		QNH	1017		QNH	999		QNH	1004				
date	29/12/04		date	24/12/04		date	27/12/04		date	28/12/04		date	28/12/04				
time	16:16		time	16:49		time	15:13		time	12:33		time	16:12				

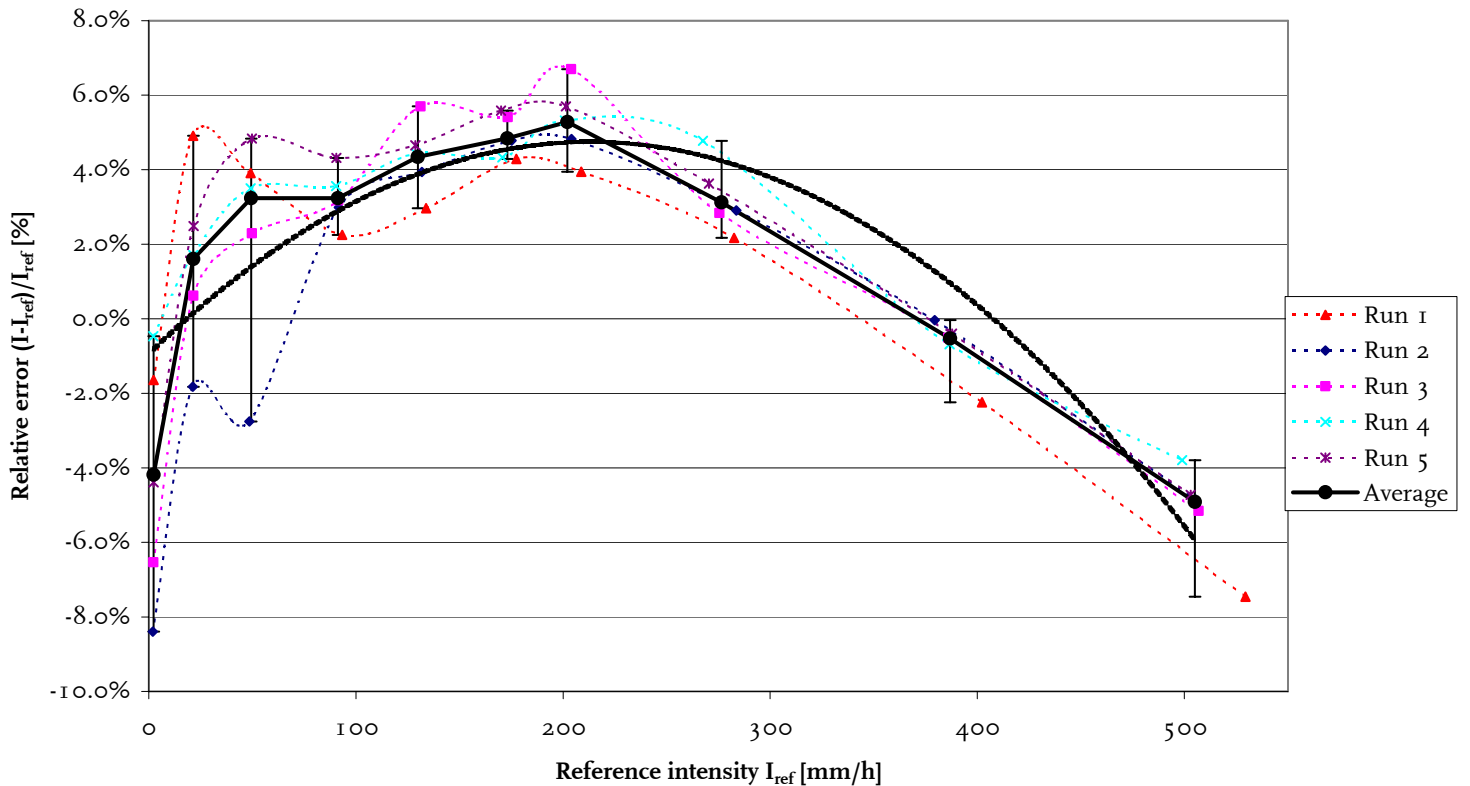

## Appendix 2: TB-3

Overview of the sensor results derived from tips versus the reference and between the 2 instruments. The coefficients of the polynomial fit and the power law fit are reported and the standard error after correction.

Parameter description	Sensor		
	639	640	Combined
Average within WMO range (mm/h)	20-700	2-700	-
Standard error sensor 1 versus 2	-	-	4.15%
R <sup>2</sup> measured versus reference	0.9997	0.9993	0.9994
Standard error measured versus reference	3.53%	2.07%	2.90%
Polynomial fit to error a	1.56E-07	-3.01E-07	-8.95E-08
Error in a	2.98E-07	8.37E-08	1.55E-07
Polynomial fit to error b	-0.0002	0.0002	0.0000
Error in b	0.0002	0.0001	0.0001
Polynomial fit to error c	0.026	-0.025	0.000
Error in c	0.023	0.007	0.013
Polynomial fit to error R <sup>2</sup>	0.1706	0.6616	0.0982
Standard error after correction	3.13%	0.99%	2.73%
Power law fit a	1.078	0.977	1.026
Error in a	0.027	0.017	0.019
Power law fit b	1.002	1.002	0.993
Error in b	0.005	0.004	0.004
Power law fit R <sup>2</sup>	0.9993	0.9993	0.9996
Standard error measured versus power law	2.28%	1.66%	3.01%

Summary of the average and standard deviation of the reference intensities and the time interval between consecutive tips for all 5 tests.

Reference intensity [mm/h]		639 tip interval [s]		Reference intensity [mm/h]		640 tip interval [s]	
Average	Std. Dev.	Average	Std. Dev.	Average	Std. Dev.	Average	Std. Dev.
2.06	0.47	347.60	160.70	2.10	0.45	372.68	133.53
22.30	0.75	34.58	12.10	21.92	0.62	36.15	11.43
50.40	1.52	16.04	5.18	48.93	1.49	16.27	5.12
89.42	2.69*	9.08	3.55	92.69	1.29	8.73	3.26
127.68	1.32	6.25	2.18	131.95	1.19	5.94	2.02
168.14	1.53	4.47	1.04	173.66	1.53	4.42	1.18
200.68	1.80	3.74	0.91	207.30	1.68	3.61	0.82
301.55	3.32	2.38	0.31	312.10	2.74	2.28	0.26
465.62	4.78	1.57	0.13	481.88	3.85	1.54	0.12
684.53	7.07	1.08	0.05	712.61	7.55	1.05	0.06

1			2			3			4			5			Tips	
TB-3			TB-3			TB-3			TB-3			TB-3				
run	#1		run	#2		run	#3		run	#4		run	#5			
Ser.nr	639		Ser.nr	639		Ser.nr	639		Ser.nr	639		Ser.nr	639			
Tamb	22.0		Tamb	21.0		Tamb	22.3		Tamb	21.7		Tamb	21.1			
Twater	19.8		Twater	18.7		Twater	19.6		Twater	19.2		Twater	18.8			
RelHum	33.0		RelHum	34.0		RelHum	32.0		RelHum	33.0		RelHum	41.0			
QNH	1021		QNH	1024		QNH	1024		QNH	1025		QNH	1017			
date	04/01/05		date	05/01/05		date	05/01/05		date	06/01/05		date	10/01/05			
time	13:07		time	07:43		time	11:28		time	07:51		time	08:36			
@precip.	measured		@precip.	measured		@precip.	measured		@precip.	measured		@precip.	measured		@precip.	result
mm/h	deviation		mm/h	deviation		mm/h	deviation		mm/h	deviation		mm/h	deviation		mm/h	deviation
2	2.1	-6.4%	2.1	41.9%	0	2.1	27.2%	I	2.1	2.5%	I	1.9	0.1%	I	2.0	9.9%
20	22.6	-3.3%	22.2	4.4%	I	22.3	0.1%	I	22.9	14.1%	O	21.4	-1.7%	I	22.0	0.9%
50	48.9	1.4%	49.4	-5.6%	O	50.4	-3.3%	I	53.0	-1.1%	I	50.2	-0.2%	I	51.2	-1.5%
90	90.6	-3.2%	89.3	-4.5%	I	88.5	-4.5%	O	89.1	-2.7%	I	90.1	0.8%	O	89.7	-3.5%
130	128.8	-2.7%	127.5	-3.4%	O	126.4	-0.8%	I	127.0	-0.7%	I	128.8	1.0%	O	127.4	-1.4%
170	169.6	4.1%	167.3	-2.4%	O	166.9	2.0%	I	167.2	-0.4%	I	169.6	0.9%	I	167.9	0.8%
200	202.4	0.6%	200.1	-1.0%	O	199.0	1.6%	I	199.5	0.5%	I	202.7	2.5%	O	200.3	0.9%
304	305.0	2.0%	300.0	0.6%	O	300.0	1.0%	I	299.1	1.3%	I	304.4	4.5%	O	301.3	1.5%
461	471.2	-1.2%	465.1	-1.0%	I	462.4	-0.4%	I	459.8	-0.3%	O	469.4	-1.2%	I	465.6	-0.9%
700	695.0	-3.1%	682.7	-2.1%	I	678.7	-2.5%	I	680.3	-1.9%	O	685.6	-2.2%	I	682.3	-2.3%
Tamb	22.1		Tamb	22.3		Tamb	22.7		Tamb	22.8		Tamb	22.3			
Twater	19.9		Twater	19.6		Twater	20.2		Twater	20.0		Twater	19.8			
RelHum	34.0		RelHum	32.0		RelHum	32.0		RelHum	32.0		RelHum	39.0			
QNH	1021		QNH	1024		QNH	1020		QNH	1028		QNH	1017			
date	04/01/05		date	05/01/05		date	05/01/05		date	06/01/05		date	10/01/05			
time	16:41		time	11:22		time	15:33		time	11:31		time	12:12			

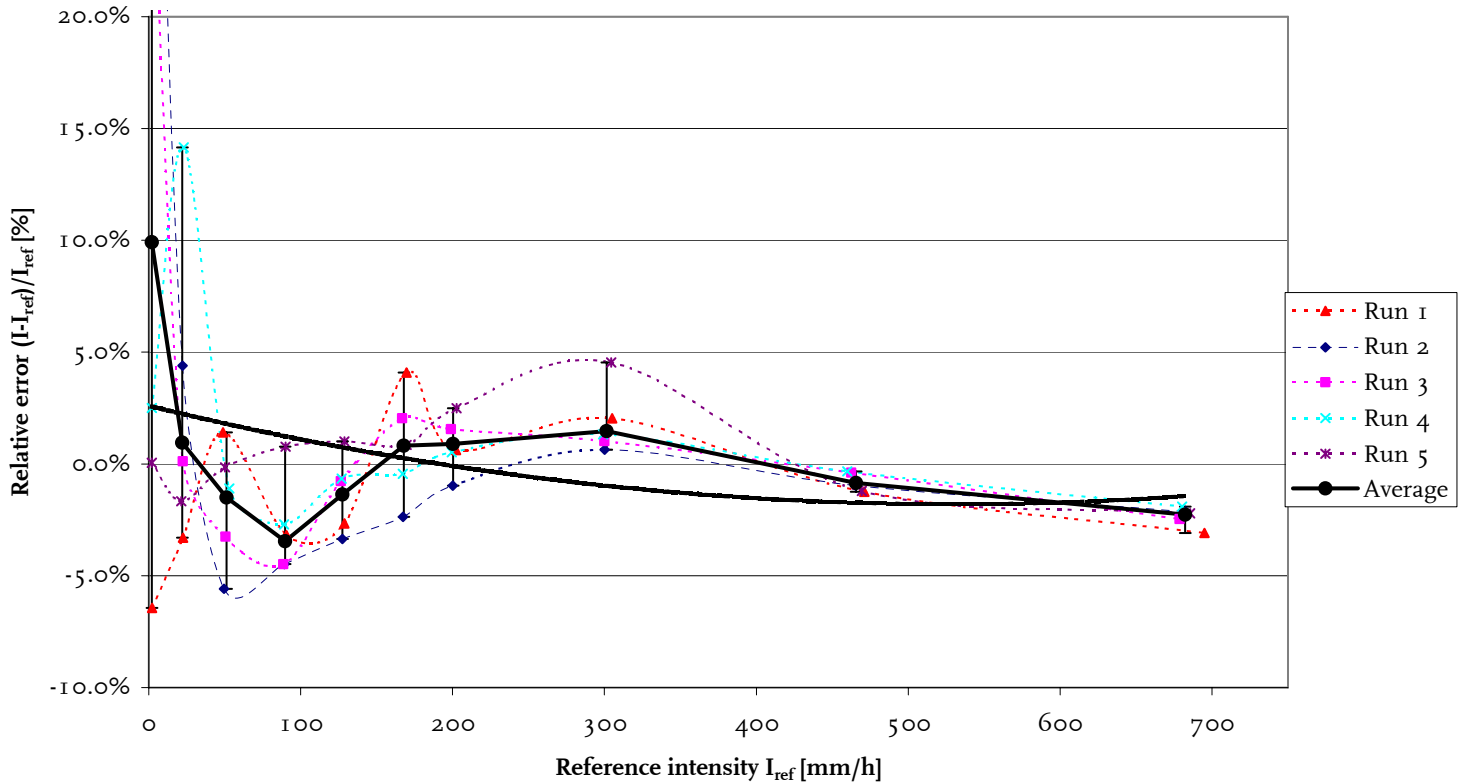

1			2			3			4			5			Tips		
TB-3			TB-3			TB-3			TB-3			TB-3					
run	#1		run	#2		run	#3		run	#4		run	#5				
Ser.nr	640		Ser.nr	640		Ser.nr	640		Ser.nr	640		Ser.nr	640				
Tamb	21.6		Tamb	22.9		Tamb	20.5		Tamb	21.5		Tamb	20.7				
Twater	19.2		Twater	19.8		Twater	18.0		Twater	18.8		Twater	18.2				
RelHum	31.0		RelHum	32.0		RelHum	46.0		RelHum	35.0		RelHum	36.0				
QNH	1025		QNH	1025		QNH	1027		QNH	1028		QNH	1023				
date	30/12/04		date	30/12/04		date	03/01/05		date	03/01/05		date	04/01/05				
time	08:10		time	11:51		time	08:21		time	12:28		time	07:33				
@precip.	measured		@precip.	measured		@precip.	measured		@precip.	measured		@precip.	measured		@precip.	result	
mm/h	deviation		mm/h	deviation		mm/h	deviation		mm/h	deviation		mm/h	deviation		mm/h	deviation	
2	2.1	-4.7%	I	2.1	-3.9%	I	2.1	-13.1%	O	2.1	1.1%	O	2.1	0.7%	I	2.1	-2.6%
20	21.7	-1.3%	I	21.8	-5.5%	O	21.7	-2.9%	I	21.8	-1.2%	I	22.7	0.0%	O	21.7	-1.8%
50	49.7	-3.9%	I	50.2	-6.4%	O	46.4	-2.2%	I	49.6	1.5%	O	48.7	1.3%	I	48.3	-1.6%
90	93.7	-4.8%	I	95.1	-5.4%	O	92.3	-1.9%	I	92.6	2.0%	O	91.5	-0.1%	I	92.5	-2.3%
130	132.8	-3.8%	I	132.9	-3.9%	O	131.6	1.2%	I	131.4	1.9%	I	130.9	4.7%	O	131.9	-0.2%
170	174.5	-2.9%	O	175.2	-1.9%	I	173.4	0.9%	I	173.2	2.4%	O	171.9	-0.5%	I	173.5	-0.5%
200	208.4	-0.8%	O	209.0	0.4%	I	207.2	2.0%	O	206.4	1.3%	I	205.7	0.2%	I	207.0	0.6%
304	314.2	2.0%	I	314.9	1.7%	O	311.7	2.3%	I	310.5	2.7%	I	309.4	3.3%	O	312.2	2.3%
461	485.9	-2.5%	I	485.9	-2.6%	O	479.5	-2.5%	I	481.0	-1.6%	O	478.1	-1.7%	I	481.2	-2.3%
700	721.2	-3.9%	O	719.6	-3.9%	I	708.3	-3.5%	I	710.2	-3.7%	I	703.5	-3.5%	O	712.7	-3.7%
Tamb	22.9		Tamb	23.1		Tamb	21.5		Tamb	21.9		Tamb	21.8				
Twater	19.8		Twater	20.4		Twater	18.8		Twater	19.2		Twater	19.5				
RelHum	32.0		RelHum	33.0		RelHum	35.0		RelHum	35.0		RelHum	33.0				
QNH	1025		QNH	1024		QNH	1028		QNH	1028		QNH	1021				
date	30/12/04		date	30/12/04		date	03/01/05		date	03/01/05		date	04/01/05				
time	11:46		time	15:25		time	12:26		time	16:04		time	12:29				

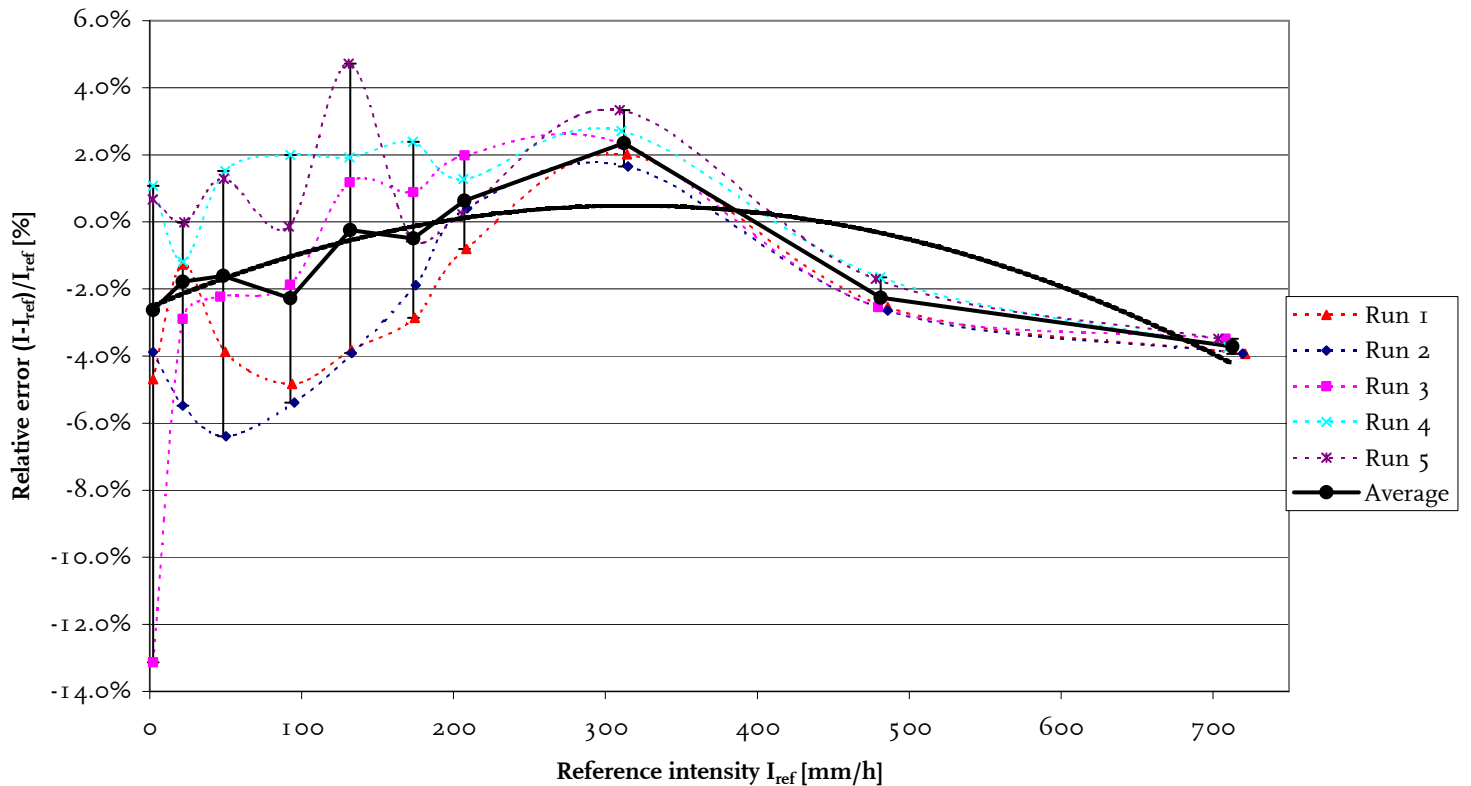

### Appendix 3: AP23

Overview of the sensor results derived from tips versus the reference. The coefficients of the polynomial fit and the power law fit are reported and the standard error after correction.

Parameter description	Sensor		
	183314	-	Combined
Average within WMO range (mm/h)	2, 50-90	-	-
Standard error sensor 1 versus 2	-	-	-
R <sup>2</sup> measured versus reference	0.9971	-	-
Standard error measured versus reference	12.35%	-	-
Polynomial fit to error a	6.81E-07	-	-
Error in a	1.03E-07	-	-
Polynomial fit to error b	-0.0009	-	-
Error in b	0.0001	-	-
Polynomial fit to error c	0.048	-	-
Error in c	0.010	-	-
Polynomial fit to error R <sup>2</sup>	0.9778	-	-
Standard error after correction	1.48%	-	-
Power law fit a	1.172	-	-
Error in a	0.067	-	-
Power law fit b	1.002	-	-
Error in b	0.011	-	-
Power law fit R <sup>2</sup>	0.9993	-	-
Standard error measured versus power law	5.20%	-	-

Summary of the average and standard deviation of the reference intensities and the time interval between consecutive tips for all 5 tests.

Reference intensity [mm/h]		183314 tip interval [s]		Reference intensity [mm/h]		tip interval [s]	
Average	Std. Dev.	Average	Std. Dev.	Average	Std. Dev.	Average	Std. Dev.
2.12	0.72	169.17	10.33				
19.13	0.72	17.79	2.60				
52.98	5.66	6.68	2.51				
98.06	1.66	4.23	1.16				
137.68	1.76	3.00	1.01				
180.36	2.27	2.29	0.38				
212.55	5.95	1.99	0.41				
301.25	5.94	1.46	0.21				
474.13	15.22	0.95	0.08				
769.50	29.41	0.61	0.03				

1			2			3			4			5			Tips		
AP23			AP23			AP23			AP23			AP23					
run	#1		run	#2		run	#3		run	#4		run	#5				
Ser.nr	183314		Ser.nr	183314		Ser.nr	183314		Ser.nr	183314		Ser.nr	183314				
Tamb	22.2		Tamb	23.3		Tamb	23.9		Tamb	21.5		Tamb	22.6				
Twater	19.2		Twater	19.9		Twater	21.0		Twater	19.3		Twater	20.0				
RelHum	32.8		RelHum	31.7		RelHum	29.9		RelHum	39.6		RelHum	36.0				
QNH	1036		QNH	1033		QNH	1032		QNH	1004		QNH	1006				
date	08/06/05		date	09/06/05		date	09/06/05		date	13/06/05		date	13/06/05				
time	13:40		time	07:38		time	11:19		time	06:59		time	10:17				
@precip.	measured		@precip.	measured		@precip.	measured		@precip.	measured		@precip.	measured		@precip.	result	
mm/h	deviation		mm/h	deviation		mm/h	deviation		mm/h	deviation		mm/h	deviation		mm/h	deviation	
2	2.1	2.9%	I	2.1	6.8%	O	2.1	5.3%	I	2.1	0.9%	I	2.0	-0.4%	O	2.1	3.0%
20	18.6	4.0%	I	19.3	9.9%	O	18.8	6.5%	I	19.4	7.4%	I	19.3	3.1%	O	18.9	5.9%
50	53.5	1.9%	I	53.7	6.2%	O	49.2	-1.7%	O	53.6	3.5%	I	54.8	-1.4%	I	54.0	1.3%
90	97.9	-5.4%	I	98.0	1.9%	O	96.7	-5.1%	I	98.9	-3.3%	I	98.6	-7.3%	O	97.8	-4.6%
130	137.0	-7.2%	I	137.4	-0.7%	O	136.4	-7.0%	I	138.8	-4.8%	I	138.5	-10.0%	O	137.4	-6.3%
170	180.6	-9.9%	I	179.4	-8.0%	I	178.5	-12.4%	O	182.1	-6.7%	O	181.0	-12.0%	I	180.3	-10.0%
200	211.3	-10.4%	I	211.9	-10.1%	I	209.9	-16.2%	O	214.9	-8.8%	O	213.7	-12.3%	I	212.3	-10.9%
307	297.5	-13.8%	O	303.6	-14.8%	I	310.2	-19.4%	O	298.7	-14.9%	I	296.1	-18.8%	I	299.5	-16.2%
470	467.3	-16.2%	O	479.1	-18.2%	I	482.8	-21.7%	I	469.5	-19.6%	I	471.8	-22.4%	O	477.1	-19.8%
720	796.9	-24.5%	I	812.9	-26.0%	O	752.8	-23.1%	I	748.9	-21.9%	O	737.9	-22.5%	I	762.5	-23.4%
Tamb	22.8		Tamb	23.8		Tamb	23.8		Tamb	22.6		Tamb	22.9				
Twater	20.0		Twater	21.0		Twater	21.0		Twater	20.0		Twater	20.3				
RelHum	34.5		RelHum	29.5		RelHum	31.3		RelHum	36.2		RelHum	34.1				
QNH	1033		QNH	1030		QNH	1030		QNH	1006		QNH	1007				
date	09/06/05		date	09/06/05		date	09/06/05		date	13/06/05		date	13/06/05				
time	07:10		time	11:07		time	14:31		time	10:15		time	13:27				

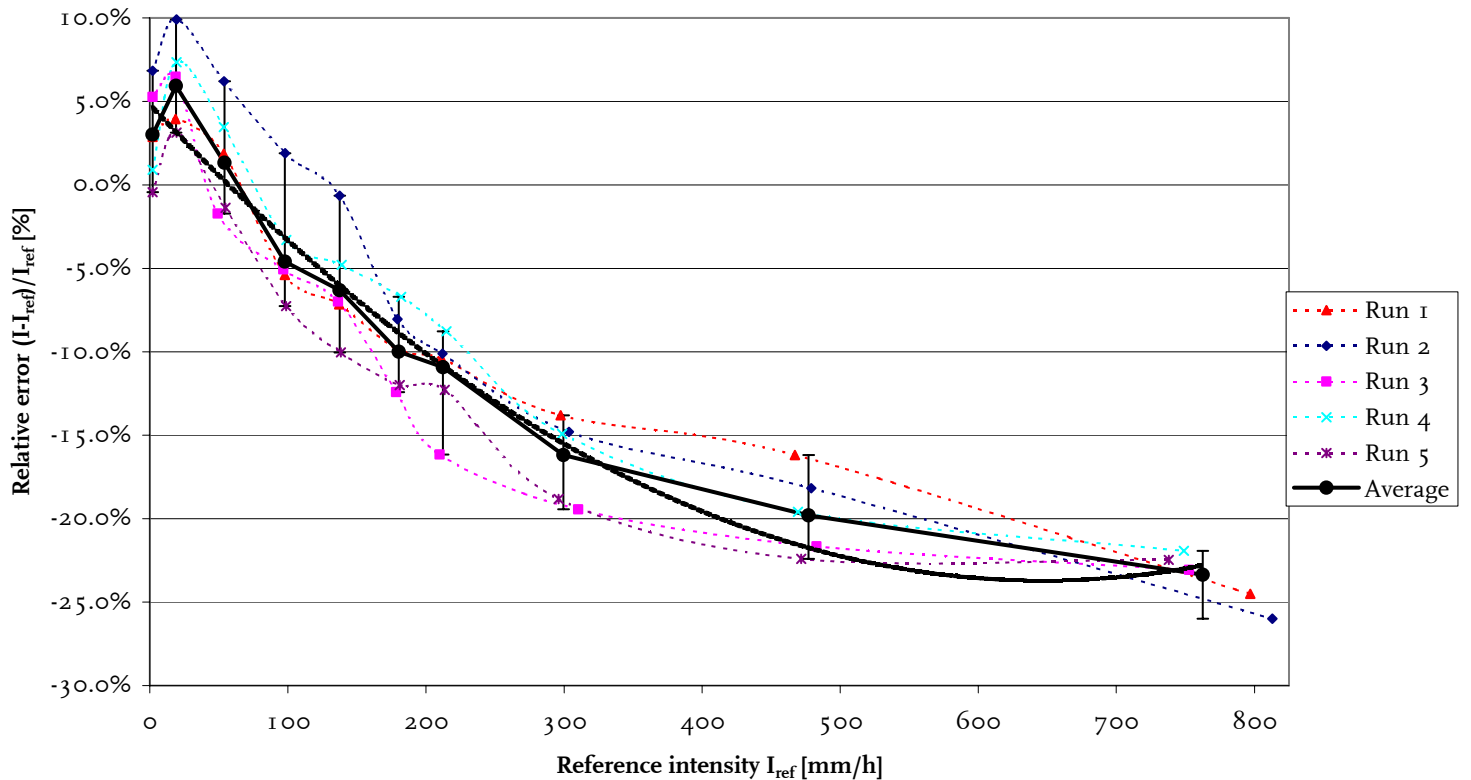

## Appendix 4: Alluvion 100

Overview of the sensor results derived from tips versus the reference and between the 2 instruments. The coefficients of the polynomial fit and the power law fit are reported and the standard error after correction.

Parameter description	Sensor		
	4002	4005	Combined
Average within WMO range (mm/h)	-	2, 90-262	
Standard error sensor 1 versus 2	-	-	17.81%
R <sup>2</sup> measured versus reference	0.9939	0.9985	0.9643
Standard error measured versus reference	17.21%	3.87%	12.48%
Polynomial fit to error a	-1.38E-06	-7.03E-07	-7.22E-07
Error in a	4.46E-07	6.27E-07	2.65E-06
Polynomial fit to error b	0.0000	-0.0001	-0.0001
Error in b	0.0001	0.0002	0.0008
Polynomial fit to error c	-0.132	0.050	-0.040
Error in c	0.008	0.012	0.051
Polynomial fit to error R <sup>2</sup>	0.9390	0.8667	0.1251
Standard error after correction	1.18%	1.35%	9.74%
Power law fit a	0.919	1.084	0.995
Error in a	0.038	0.039	0.082
Power law fit b	0.983	0.983	0.981
Error in b	0.009	0.007	0.017
Power law fit R <sup>2</sup>	0.9989	0.9989	0.9648
Standard error measured versus power law	3.35%	2.98%	15.43%

Summary of the average and standard deviation of the reference intensities and the time interval between consecutive increments for all 5 tests.

Reference intensity [mm/h]		4002 tip interval [s]		Reference intensity [mm/h]		4005 tip interval [s]	
Average	Std. Dev.	Average	Std. Dev.	Average	Std. Dev.	Average	Std. Dev.
2.32	0.28	354.20	172.51	2.41	0.34	292.60	127.66
22.66	1.37	36.18	18.68	22.66	2.81	29.67	11.86
52.56	4.61	16.72	8.29	54.04	3.94	12.93	5.87
88.50	12.88**	10.74	5.18	94.17	5.83	8.01	2.77
117.18	26.25**	8.58	4.48	127.61	7.67	6.18	2.36
166.89	8.59	6.46	2.98	159.00	10.66	5.33	8.12
193.28	13.68	5.73	2.93	194.72*	13.94*	3.92*	0.97*
208.48	19.40	5.26	2.72	218.81	21.75	3.76	4.97
258.56	13.51	4.14	2.05	261.80*	16.95*	2.88*	0.46*
294.65	17.28	3.77	1.62	300.03	17.64	2.95	3.07

\* These values are calculated from 4 runs since run 5 had no increments due to continuous siphoning.

\*\* During run 4 only 66 and 67 mm/h was supplied as the reference intensity at 90 and 130 mm/h, respectively.

1			2			3			4			5			Tips		
Alluvion 100			Alluvion 100			Alluvion 100			Alluvion 100			Alluvion 100					
run	#1		run	#2		run	#3		run	#4		run	#5				
Ser.nr	4002		Ser.nr	4002		Ser.nr	4002		Ser.nr	4002		Ser.nr	4002				
Tamb	21.5		Tamb	22.6		Tamb	22.2		Tamb	22.4		Tamb	21.2				
Twater	19.5		Twater	19.2		Twater	19.5		Twater	19.8		Twater	18.0				
RelHum	40.0		RelHum	38.0		RelHum	35.0		RelHum	23.0		RelHum	24.0				
QNH	1021		QNH	1022		QNH	1019		QNH	1024		QNH	1025				
date	11/01/05		date	11/01/05		date	12/01/05		date	24/01/05		date	25/01/05				
time	06:22		time	10:17		time	08:41		time	12:10		time	07:53				
@precip.	measured		@precip.	measured		@precip.	measured		@precip.	measured		@precip.	measured		@precip.	result	
mm/h	deviation		mm/h	deviation		mm/h	deviation		mm/h	deviation		mm/h	deviation		mm/h	deviation	
2	2.2	-2.6%	0	2.3	-10.9%	I	2.6	-7.8%	I	2.3	-20.0%	I	2.2	-21.6%	o	2.4	-12.9%
20	22.3	-13.8%	I	22.4	-10.9%	I	25.0	-18.1%	o	22.1	-14.7%	I	22.1	-4.3%	o	22.2	-13.1%
50	53.1	-12.1%	o	53.7	-13.6%	I	59.1	-16.9%	o	48.2	-13.8%	I	51.1	-12.2%	I	51.0	-13.2%
90	94.5	-14.8%	I	94.2	-16.2%	I	100.5	-13.7%	o	66.1	-13.8%	I	90.8	-16.4%	o	84.9	-14.9%
130	132.6	-14.7%	I	132.2	-15.3%	I	133.2	-15.1%	I	67.6	-14.1%	o	126.0	-16.4%	o	132.6	-15.1%
170	168.5	-16.4%	o	167.9	-17.0%	I	161.8	-16.7%	I	171.5	-16.9%	I	169.7	-18.4%	o	167.1	-16.9%
200	192.5	-16.2%	o	191.3	-17.4%	I	178.1	-19.1%	I	202.1	-18.8%	I	200.1	-19.8%	o	190.5	-18.5%
229	206.9	-17.7%	I	204.3	-17.7%	I	186.3	-16.9%	o	228.3	-17.9%	I	226.2	-22.0%	o	213.2	-17.8%
262	260.3	-20.0%	I	258.2	-19.5%	I	256.9	-18.3%	o	262.1	-20.0%	I	259.4	-23.9%	o	260.2	-19.8%
300	297.6	-24.3%	I	298.5	-20.4%	o	298.2	-34.1%	o	297.3	-27.1%	I	295.7	-26.2%	I	296.9	-25.9%
Tamb	22.6		Tamb	22.8		Tamb	23.0		Tamb	22.5		Tamb	22.1				
Twater	19.2		Twater	20.6		Twater	19.5		Twater	19.4		Twater	18.5				
RelHum	38.0		RelHum	37.0		RelHum	32.0		RelHum	22.5		RelHum	22.0				
QNH	1022		QNH	1019		QNH	1018		QNH	1025		QNH	1027				
date	11/01/05		date	11/01/05		date	12/01/05		date	24/01/05		date	25/01/05				
time	10:07		time	14:00		time	12:39		time	16:13		time	11:41				

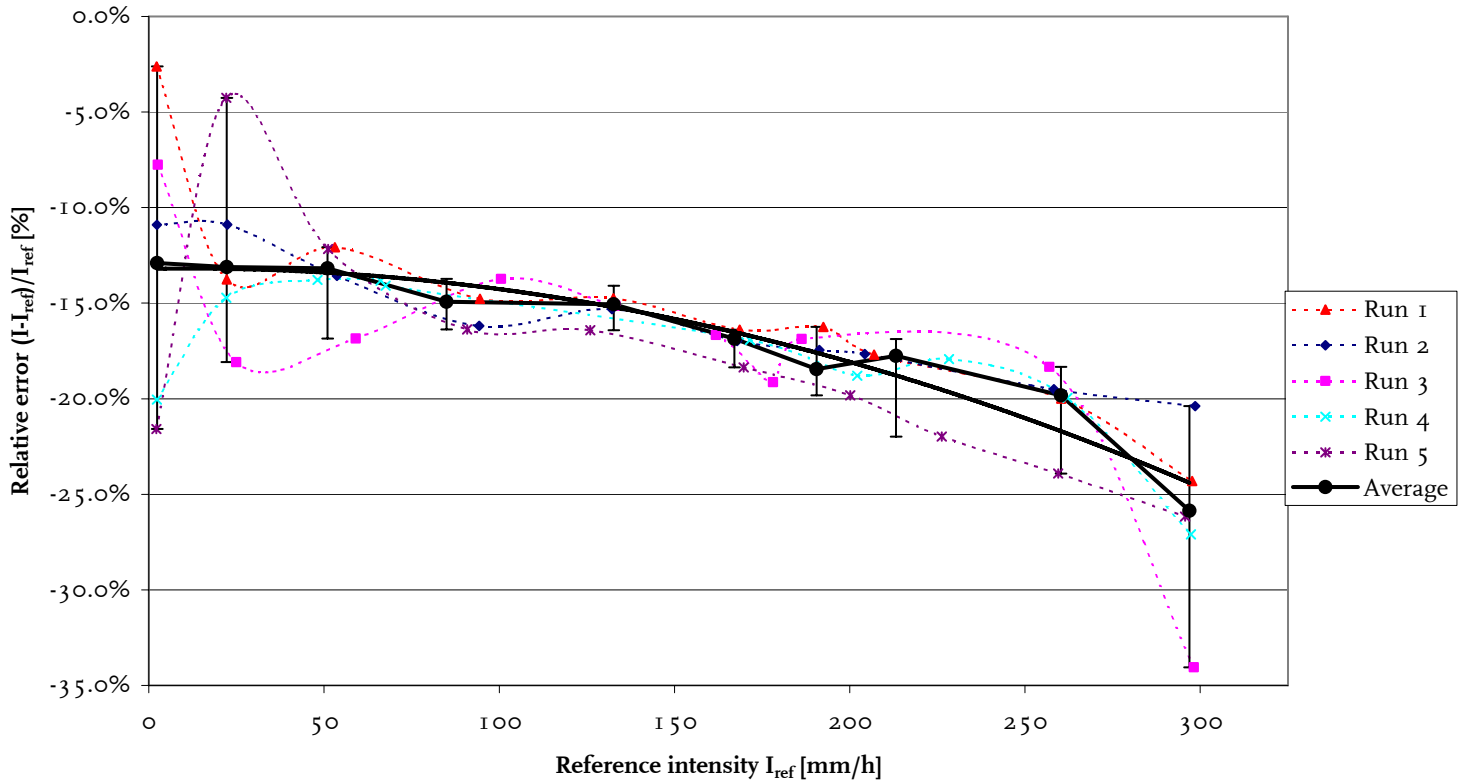

1			2			3			4			5			Tips	
Alluvion 100			Alluvion 100			Alluvion 100			Alluvion 100			Alluvion 100				
run	#1		run	#2		run	#3		run	#4		run	#5			
Ser.nr	4005		Ser.nr	4005		Ser.nr	4005		Ser.nr	4005		Ser.nr	4005			
Tamb	22.0		Tamb	21.7		Tamb	22.7		Tamb	22.4		Tamb	21.2			
Twater	23.1		Twater	18.1		Twater	19.2		Twater	19.8		Twater	17.8			
RelHum	32.0		RelHum	29.0		RelHum	28.0		RelHum	35.0		RelHum	25.0			
QNH	1018		QNH	1007		QNH	1009		QNH	1004		QNH	1022			
date	12/01/05		date	19/01/05		date	19/01/05		date	20/01/05		date	24/01/05			
time	12:52		time	08:56		time	12:38		time	09:49		time	08:29			
@precip.	measured		@precip.	measured		@precip.	measured		@precip.	measured		@precip.	measured		@precip.	result
mm/h	deviation		mm/h	deviation		mm/h	deviation		mm/h	deviation		mm/h	deviation		mm/h	deviation
2	2.7	-0.5% I	2.4	5.1% I		2.6	-1.6% O		2.2	2.9% I		2.1	5.4% O		2.4	2.5%
20	24.1	4.0% O	23.2	4.4% I		23.6	5.9% I		21.8	7.9% O		21.8	7.6% I		22.9	6.0%
50	57.1	-47.5% O	55.3	4.6% I		55.9	7.6% O		55.7	6.7% I		51.2	5.9% I		54.1	5.7%
90	97.0	5.3% O	95.2	5.0% I		95.7	4.0% O		96.2	4.8% I		91.2	4.0% I		94.2	4.6%
130	129.2	1.8% I	127.7	2.4% O		129.4	1.7% I		130.6	2.0% I		127.2	1.6% I		129.7	1.8%
170	159.1	-56.6% O	156.1	2.1% I		159.4	-0.4% I		162.2	2.2% O		170.3	-4.9% I		162.0	-1.1%
200	176.6	-1.2% I	195.5	-1.3% I		205.4	-0.4% I		204.4	-2.3% O		200.0	0.0% O		192.5	-1.0%
229	189.1	-0.2% O	225.4	-3.1% I		237.0	-3.5% I		230.1	-2.0% I		226.8	-68.9% O		230.8	-2.9%
262	256.6	-4.0% I	262.0	-4.5% O		274.2	-2.4% I		262.5	-1.3% I		262.0	0.0% O		264.4	-2.6%
300	298.1	-7.0% I	300.1	-5.2% I		317.1	-5.2% I		300.7	-4.2% O		295.7	-44.6% O		305.1	-5.8%
Tamb	23.2		Tamb	22.7		Tamb	22.7		Tamb	23.0		Tamb	22.4			
Twater	19.4		Twater	19.2		Twater	20.2		Twater	20.3		Twater	19.8			
RelHum	35.0		RelHum	28.0		RelHum	28.0		RelHum	34.0		RelHum	23.0			
QNH	1019		QNH	1009		QNH	1010		QNH	1001		QNH	1024			
date	12/01/05		date	19/01/05		date	19/01/05		date	20/01/05		date	24/01/05			
time	16:41		time	12:32		time	16:09		time	13:25		time	12:00			

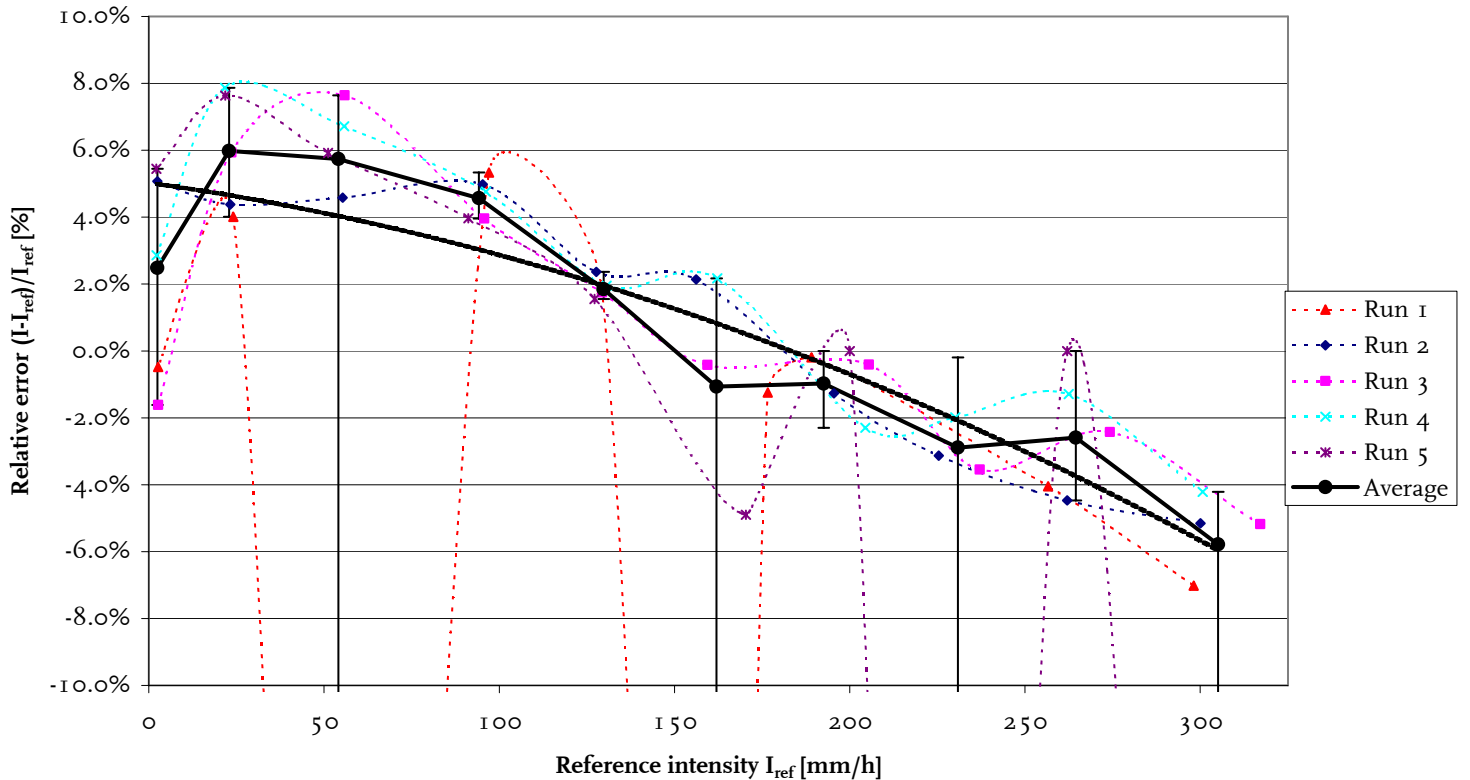

## Appendix 5: MRW500

Overview of the sensor results derived from the reported precipitation amount versus the reference and between the 2 instruments for the precipitation accumulation results. The coefficients of the polynomial fit and the power law fit are reported and the standard error after correction.

Parameter description	Sensor		
	A	B	Combined
Average within WMO range (mm/h)	2-400	2-400	
Standard error sensor 1 versus 2	-	-	0.16%
R <sup>2</sup> measured versus reference	1.0000	1.0000	1.0000
Standard error measured versus reference	1.40%	1.37%	1.39%
Polynomial fit to error a	-3.59E-07	-3.34E-07	-3.46E-07
Error in a	2.37E-07	2.08E-07	1.43E-07
Polynomial fit to error b	0.0002	0.0002	0.0002
Error in b	0.0001	0.0001	0.0001
Polynomial fit to error c	-0.020	-0.021	-0.021
Error in c	0.007	0.007	0.004
Polynomial fit to error R <sup>2</sup>	0.3213	0.3915	0.3521
Standard error after correction	0.91%	0.82%	0.87%
Power law fit a	0.967	0.966	0.966
Error in a	0.008	0.006	0.005
Power law fit b	1.006	1.006	1.006
Error in b	0.002	0.001	0.001
Power law fit R <sup>2</sup>	1.0000	1.0000	1.0000
Standard error measured versus power law	0.73%	0.60%	0.67%

Summary of the average and standard deviation of the running 1-minute averaged reference and measured intensities for all 5 tests.

Reference intensity [mm/h]		A intensity [mm/h]		Reference intensity [mm/h]		B intensity [mm/h]	
Average	Std. Dev.	Average	Std. Dev.	Average	Std. Dev.	Average	Std. Dev.
2.07	0.08	2.02	1.20	2.08	0.08	2.04*	1.82*
19.88	0.20	19.91	2.29	19.93	0.14	19.86	2.02
52.68	2.81**	52.47	3.57	53.75	0.37	53.54	2.61
96.15	0.62	95.88*	2.46*	96.49	0.66	96.40*	2.97*
135.28	0.51	135.20	2.71	135.81	0.69	135.63	3.29
177.15	0.54	176.58	3.58	178.00	0.93	177.75	4.48
209.02	0.81	208.83	4.18	210.20	1.02	210.38	4.87
246.38	2.80	245.63*	4.88*	247.53	1.54	246.96	4.07
305.11	2.80	303.93	6.14	307.70	1.42	307.15	6.47
396.28	5.88	395.70	9.95	396.44	2.35	396.04	7.69

\* These results are corrected for faulty sensor reports.

\*\* During 1 minute in run 2 a lower flow rate was provided by the reference.

Overview of the sensor results derived from tips versus the reference and between the 2 instruments for the pulse output. The coefficients of the polynomial fit and the power law fit are reported and the standard error after correction.

Parameter description	Sensor		
	A	B	Combined
Average within WMO range (mm/h)	2-400	2-400	
Standard error sensor 1 versus 2	-	-	0.48%
R <sup>2</sup> measured versus reference	1.0000	1.0000	1.0000
Standard error measured versus reference	0.71%	0.73%	0.72%
Polynomial fit to error a	-2.15E-07	-2.35E-07	-2.25E-07
Error in a	1.17E-07	1.42E-07	8.47E-08
Polynomial fit to error b	0.0001	0.0001	0.0001
Error in b	0.0000	0.0001	0.0000
Polynomial fit to error c	-0.012	-0.010	-0.011
Error in c	0.004	0.005	0.003
Polynomial fit to error R <sup>2</sup>	0.5217	0.4307	0.4650
Standard error after correction	0.47%	0.55%	0.52%
Power law fit a	0.980	0.982	0.981
Error in a	0.004	0.005	0.003
Power law fit b	1.004	1.004	1.004
Error in b	0.001	0.001	0.001
Power law fit R <sup>2</sup>	1.0000	1.0000	1.0000
Standard error measured versus power law	0.33%	0.44%	0.40%

Summary of the average and standard deviation of the reference intensities and the time interval between consecutive increments for all 5 tests.

Reference intensity [mm/h]		A tip interval [s]		Reference intensity [mm/h]		B tip interval [s]	
Average	Std. Dev.	Average	Std. Dev.	Average	Std. Dev.	Average	Std. Dev.
2.11	0.72	171.70	41.22	2.13	0.72	176.78	38.24
19.92	0.62	18.16	5.15	19.99	0.61	18.09	3.87
52.61	4.05	6.88	2.48	53.81	0.88	6.74	2.50
96.23	1.42	4.15	1.19	96.61	1.86	4.12	1.26
135.37	1.55	2.86	0.96	135.90	1.77	2.92	1.04
177.24	1.66	2.14	0.51	178.10	1.80	2.10	0.42
209.16	2.09	1.78	0.36	210.33	1.97	1.75	0.31
246.42	5.05	1.50	0.25	247.63	4.04	1.49	0.23
305.15	3.79	1.20	0.16	307.79	2.72	1.19	0.18
396.30	7.29	0.92	0.12	396.49	4.12	0.92	0.11

1			2			3			4			5			Intensity		
MRW <sub>500</sub>			MRW <sub>500</sub>			MRW <sub>500</sub>			MRW <sub>500</sub>			MRW <sub>500</sub>					
run	#1		run	#2		run	#3		run	#4		run	#5				
Ser.nr	A		Ser.nr	A		Ser.nr	A		Ser.nr	A		Ser.nr	A				
Tamb	22.6		Tamb	22.6		Tamb	22.4		Tamb	23.2		Tamb	22.7				
Twater	18.3		Twater	14.5		Twater	19.0		Twater	15.5		Twater	19.0				
RelHum	37.7		RelHum	38.9		RelHum	34.4		RelHum	30.1		RelHum	25.4				
QNH	1014		QNH	1014		QNH	1022		QNH	1024		QNH	1026				
date	29/03/05		date	30/03/05		date	31/03/05		date	31/03/05		date	01/04/05				
time	10:54		time	12:03		time	06:49		time	12:18		time	08:29				
@precip.	measured		@precip.	measured		@precip.	measured		@precip.	measured		@precip.	measured		@precip.	result	
mm/h	deviation		mm/h	deviation		mm/h	deviation		mm/h	deviation		mm/h	deviation		mm/h	deviation	
2	2.0	6.3%	o	2.1	-3.3%	I	2.1	-6.8%	I	2.1	-2.1%	I	2.1	-8.1%	o	2.1	-4.0%
20	20.0	-1.5%	o	19.8	0.2%	o	20.0	-0.8%	I	19.8	-0.5%	I	19.6	-0.9%	I	19.8	-0.7%
50	52.9	0.1%	o	47.9	0.1%	I	53.0	0.0%	I	52.4	0.0%	I	52.8	-0.3%	o	51.1	0.0%
90	95.6	-0.1%	I	94.9	-0.4%	I	95.7	-0.1%	o	95.7	-0.8%	o	95.3	-0.6%	I	95.3	-0.4%
130	135.4	-0.4%	I	134.5	-0.1%	o	134.8	-0.3%	I	134.5	-0.4%	I	134.0	-0.9%	o	134.9	-0.4%
170	176.5	-0.2%	o	175.8	-0.8%	o	176.3	-0.5%	I	176.2	-0.8%	I	175.4	-0.4%	I	176.0	-0.6%
200	208.4	0.2%	o	207.0	-0.2%	I	208.0	-0.1%	I	208.8	-0.3%	I	206.8	-0.3%	o	208.0	-0.2%
252	246.2	-1.6%	o	245.4	-0.9%	I	248.0	-0.7%	o	247.8	-1.1%	I	241.4	-0.8%	I	244.9	-0.9%
317	304.9	-1.2%	o	305.1	-0.8%	I	304.1	-0.5%	o	307.1	-1.0%	I	298.9	-0.8%	I	303.7	-0.9%
400	390.7	-0.8%	o	404.6	-0.5%	o	397.6	-0.6%	I	393.7	-0.7%	I	386.2	-0.8%	I	392.5	-0.7%
Tamb	22.6		Tamb	23.1		Tamb	22.8		Tamb	23.1		Tamb	23.4				
Twater	17.0		Twater	18.5		Twater	18.8		Twater	17.8		Twater	18.0				
RelHum	38.4		RelHum	28.5		RelHum	31.0		RelHum	29.9		RelHum	26.7				
QNH	1013		QNH	1026		QNH	1023		QNH	1024		QNH	1026				
date	29/03/05		date	01/04/05		date	31/03/05		date	31/03/05		date	01/04/05				
time	12:37		time	13:35		time	08:32		time	10:26		time	10:17				

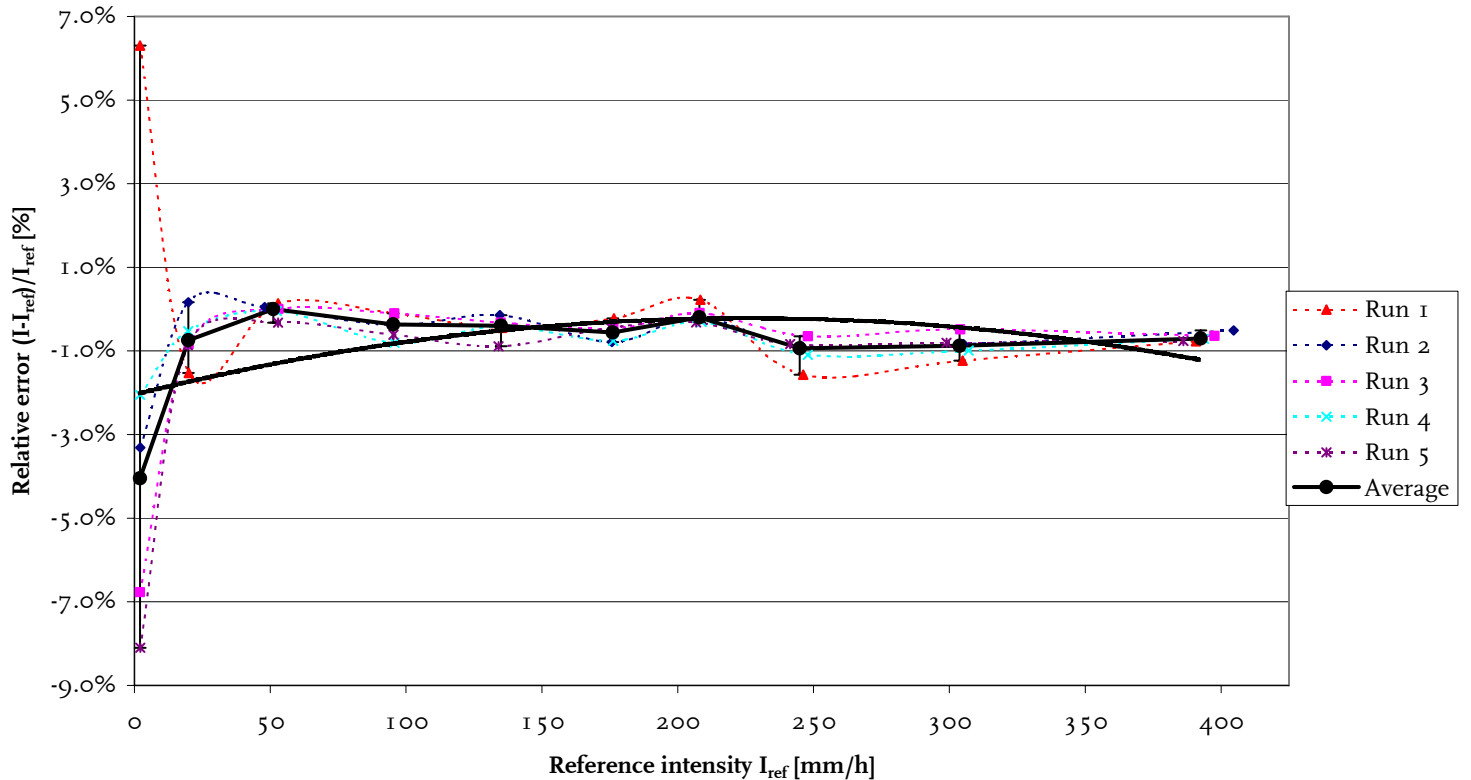

1			2			3			4			5			Intensity		
MRW <sub>500</sub>			MRW <sub>500</sub>			MRW <sub>500</sub>			MRW <sub>500</sub>			MRW <sub>500</sub>					
run	#1		run	#2		run	#3		run	#4		run	#5				
Ser.nr	B		Ser.nr	B		Ser.nr	B		Ser.nr	B		Ser.nr	B				
Tamb	23.6		Tamb	23.9		Tamb	24.0		Tamb	23.0		Tamb	23.3				
Twater	19.0		Twater	17.5		Twater	19.0		Twater	21.0		Twater	19.5				
RelHum	30.1		RelHum	31.7		RelHum	33.7		RelHum	26.9		RelHum	28.8				
QNH	1021		QNH	1020		QNH	1019		QNH	1018		QNH	1017				
date	04/04/05		date	04/04/05		date	04/04/05		date	06/04/05		date	06/04/05				
time	08:27		time	10:25		time	12:26		time	06:11		time	08:05				
@precip.	measured		@precip.	measured		@precip.	measured		@precip.	measured		@precip.	measured		@precip.	result	
mm/h	deviation		mm/h	deviation		mm/h	deviation		mm/h	deviation		mm/h	deviation		mm/h	deviation	
2	2.1	-6.4%	0	2.1	-4.2%	I	2.1	-6.3%	I	2.1	-1.3%	O	2.1	-1.4%	I	2.1	-4.0%
20	19.8	-0.6%	I	19.7	-0.8%	I	20.0	-0.8%	I	20.0	-0.2%	O	20.0	-1.8%	O	19.8	-0.8%
50	53.1	-1.3%	O	53.7	-0.4%	I	53.5	-0.7%	I	52.9	0.6%	O	53.1	-0.1%	I	53.5	-0.4%
90	95.3	-0.2%	I	97.2	-0.3%	I	95.6	-0.1%	O	96.0	-1.1%	O	95.8	-0.9%	I	96.1	-0.4%
130	135.1	-0.3%	I	136.4	-0.8%	I	135.2	-0.4%	I	135.3	-0.2%	O	134.4	-0.8%	O	135.6	-0.5%
170	176.8	-0.6%	I	178.5	-0.1%	O	176.7	-0.6%	I	177.0	-0.7%	O	175.6	-0.5%	I	176.4	-0.6%
200	208.4	-0.6%	O	210.2	-0.6%	I	208.8	0.0%	I	208.9	-0.3%	I	207.8	0.3%	O	209.3	-0.3%
252	246.2	-0.6%	I	247.2	-1.0%	I	244.9	-0.6%	O	249.2	-1.0%	I	246.0	-1.2%	O	247.5	-0.9%
317	307.3	-1.2%	O	307.1	-0.5%	I	304.7	-0.3%	O	306.3	-0.7%	I	307.9	-0.7%	I	307.1	-0.6%
400	393.8	-1.0%	O	395.7	-0.7%	I	393.3	-0.6%	I	394.4	-0.5%	O	399.9	-0.7%	I	396.3	-0.6%
Tamb	23.9		Tamb	23.8		Tamb	23.5		Tamb	23.2		Tamb	23.2				
Twater	18.0		Twater	19.0		Twater	19.0		Twater	20.0		Twater	18.5				
RelHum	31.7		RelHum	33.6		RelHum	34.7		RelHum	29.2		RelHum	28.8				
QNH	1020		QNH	1019		QNH	1019		QNH	1017		QNH	1015				
date	04/04/05		date	04/04/05		date	04/04/05		date	06/04/05		date	06/04/05				
time	10:19		time	12:20		time	14:19		time	08:00		time	09:54				

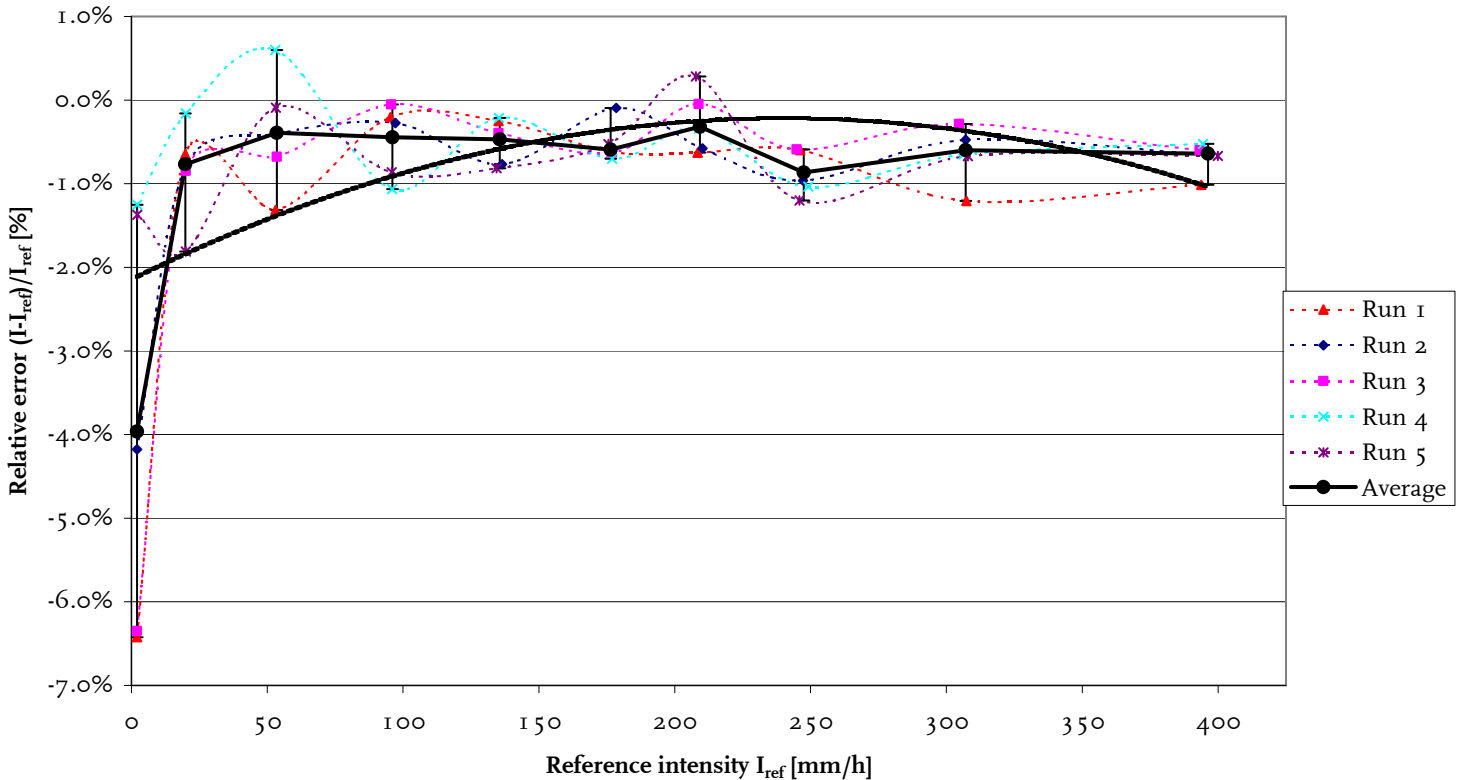

## Appendix 6: MR3H-FC

Overview of the sensor results derived from the corrected tips versus the reference and between the 2 instruments for the corrected pulse output. The coefficients of the polynomial fit and the power law fit are reported and the standard error after correction.

Parameter description	Sensor		
	008/04	009/04	Combined
Average within WMO range (mm/h)	20-130	500	
Standard error sensor 1 versus 2	-	-	2.94%
R <sup>2</sup> measured versus reference	0.9999	0.9977	0.9978
Standard error measured versus reference	5.97%	6.76%	6.38%
Polynomial fit to error a	-7.75E-08	5.34E-07	2.44E-07
Error in a	1.70E-07	1.60E-07	1.80E-07
Polynomial fit to error b	0.0000	-0.0002	-0.0001
Error in b	0.0001	0.0001	0.0001
Polynomial fit to error c	-0.050	-0.065	-0.057
Error in c	0.008	0.008	0.009
Polynomial fit to error R <sup>2</sup>	0.4303	0.7921	0.1219
Standard error after correction	1.10%	1.08%	1.85%
Power law fit a	0.949	0.914	0.932
Error in a	0.015	0.022	0.013
Power law fit b	1.005	1.005	1.002
Error in b	0.003	0.005	0.003
Power law fit R <sup>2</sup>	0.9979	0.9979	0.9977
Standard error measured versus power law	1.44%	2.20%	2.06%

Summary of the average and standard deviation of the reference intensities and the time interval between consecutive increments for all 5 tests.

Reference intensity [mm/h]		008/04 tip interval [s]		Reference intensity [mm/h]		009/04 tip interval [s]	
Average	Std. Dev.	Average	Std. Dev.	Average	Std. Dev.	Average	Std. Dev.
2.11	0.27	187.29	10.46	2.10	0.26	186.18	24.12
19.72	0.38	19.32	3.03	19.76	0.39	19.74	3.35
53.19	3.19	8.07	2.56	53.20	2.71	8.21	2.54
96.00	1.17	4.11	0.92	95.92	1.35	4.21	0.93
135.23	1.15	2.87	0.48	135.13	1.32	2.94	0.45
177.31	1.22	2.19	0.27	177.21	1.58	2.25	0.30
210.45	2.40	1.85	0.24	209.31	1.94	1.92	0.27
265.55	2.67	1.45	0.09	263.91	6.22	1.44	0.10
358.83	3.76	1.10	0.08	360.34	86.21*	1.08	0.08
499.05	5.35	0.78	0.04	501.29	6.95	0.72	0.04

\* The reference intensity of 368 mm/h in run 5 showed 2 larger peaks resulting in a high standard deviation.

Overview of the sensor results derived from the raw tips versus the reference and between the 2 instruments for the raw reed output. The coefficients of the polynomial fit and the power law fit are reported and the standard error after correction.

Parameter description	Sensor		
	008/04	009/04	Combined
Average within WMO range (mm/h)	-	-	
Standard error sensor 1 versus 2	-	-	5.13%
R <sup>2</sup> measured versus reference	0.9991	0.9873	0.9864
Standard error measured versus reference	15.73%	15.02%	15.38%
Polynomial fit to error a	8.66E-07	2.07E-06	1.50E-06
Error in a	1.27E-07	2.10E-07	2.80E-07
Polynomial fit to error b	-0.0008	-0.0011	-0.0009
Error in b	0.0001	0.0001	0.0001
Polynomial fit to error c	-0.059	-0.064	-0.061
Error in c	0.006	0.010	0.014
Polynomial fit to error R <sup>2</sup>	0.9802	0.9346	0.7442
Standard error after correction	0.85%	1.60%	3.17%
Power law fit a	1.004	0.944	0.974
Error in a	0.034	0.053	0.031
Power law fit b	0.979	0.979	0.971
Error in b	0.007	0.011	0.007
Power law fit R <sup>2</sup>	0.9858	0.9858	0.9853
Standard error measured versus power law	3.06%	5.20%	4.74%

1			2			3			4			5			Corrected	
MR <sub>3</sub> H-FC			MR <sub>3</sub> H-FC			MR <sub>3</sub> H-FC			MR <sub>3</sub> H-FC			MR <sub>3</sub> H-FC				
run	#1		run	#2		run	#3		run	#4		run	#5			
Ser.nr	008/04		Ser.nr	008/04		Ser.nr	008/04		Ser.nr	008/04		Ser.nr	008/04			
Tamb	23.2		Tamb	23.0		Tamb	23.2		Tamb	21.8		Tamb	22.7			
Twater	17.0		Twater	19.0		Twater	20.1		Twater	15.5		Twater	19.5			
RelHum	37.7		RelHum	34.6		RelHum	36.0		RelHum	26.9		RelHum	25.0			
QNH	1022		QNH	1026		QNH	1026		QNH	1017		QNH	1014			
date	17/03/05		date	18/03/05		date	18/03/05		date	21/03/05		date	21/03/05			
time	12:38		time	08:18		time	12:12		time	08:46		time	13:46			
@precip.	measured		@precip.	measured		@precip.	measured		@precip.	measured		@precip.	measured		@precip.	result
mm/h	deviation		mm/h	deviation		mm/h	deviation		mm/h	deviation		mm/h	deviation		mm/h	deviation
2	2.1	-8.5% I	2.1	-4.7% O		2.1	-5.4% I		2.1	-11.5% O		2.1	-7.6% I		2.1	-7.2% I
20	19.5	-5.8% I	19.6	-1.4% O		19.9	-1.8% I		19.5	-4.5% I		19.9	-8.5% O		19.6	-4.0% O
50	52.9	-4.9% I	53.6	-4.6% I		53.4	-5.1% I		52.4	-4.4% O		54.0	-6.0% O		53.3	-4.9% O
90	95.8	-3.0% I	95.7	-4.1% I		95.9	-1.9% O		94.9	-3.8% I		97.4	-4.3% O		95.5	-3.6% O
130	135.2	-4.1% I	135.0	-4.3% I		134.7	-2.9% O		134.3	-5.5% I		136.7	-6.0% O		134.9	-4.6% O
170	177.4	-4.7% O	177.5	-6.6% I		176.6	-5.1% I		176.8	-5.8% I		178.4	-6.7% O		177.0	-5.8% O
200	213.6	-4.1% O	209.3	-7.2% I		209.0	-6.1% I		208.9	-5.9% I		210.8	-7.6% O		209.1	-6.4% O
271	264.3	-4.5% O	266.4	-5.4% I		269.7	-6.2% I		265.0	-7.7% I		263.1	-8.1% O		267.0	-6.4% O
368	357.0	-6.9% O	360.5	-7.2% I		364.3	-7.4% I		358.0	-8.4% I		354.3	-10.2% O		360.9	-7.7% O
500	505.2	-9.4% I	501.4	-5.2% I		502.0	-3.8% O		493.1	-7.8% I		493.6	-10.2% O		499.9	-7.4% O
Tamb	23.1		Tamb	22.9		Tamb	23.3		Tamb	22.5		Tamb	22.6			
Twater	20.5		Twater	20.1		Twater	21		Twater	19.5		Twater	20.5			
RelHum	37.4		RelHum	35.4		RelHum	38.8		RelHum	24.4		RelHum	26.6			
QNH	1023		QNH	1026		QNH	1026		QNH	1014		QNH	1012			
date	17/03/05		date	18/03/05		date	18/03/05		date	21/03/05		date	21/03/05			
time	17:24		time	12:04		time	15:33		time	13:38		time	17:39			

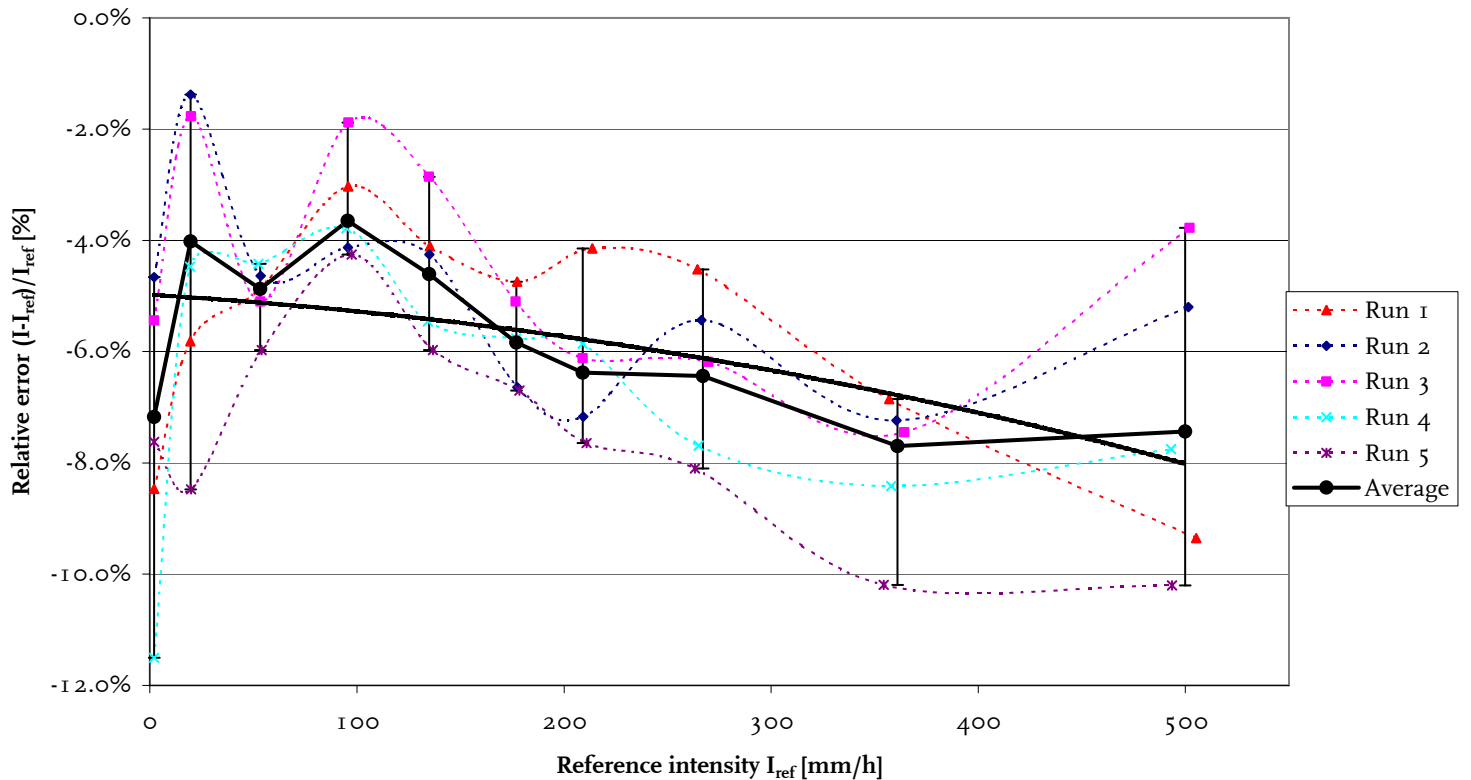

1			2			3			4			5			Corrected		
MR <sub>3</sub> H-FC			MR <sub>3</sub> H-FC			MR <sub>3</sub> H-FC			MR <sub>3</sub> H-FC			MR <sub>3</sub> H-FC					
run	#1		run	#2		run	#3		run	#4		run	#5				
Ser.nr	009/04		Ser.nr	009/04		Ser.nr	009/04		Ser.nr	009/04		Ser.nr	009/04				
Tamb	22.5		Tamb	23.2		Tamb	22.9		Tamb	22.6		Tamb	23.2				
Twater	16.2		Twater	20.0		Twater	19.0		Twater	19.6		Twater	21.0				
RelHum	37.5		RelHum	35.7		RelHum	36.5		RelHum	39.2		RelHum	39.2				
QNH	1017		QNH	1018		QNH	1014		QNH	1017		QNH	1017				
date	23/03/05		date	23/03/05		date	24/03/05		date	25/03/05		date	25/03/05				
time	08:19		time	12:29		time	08:15		time	08:00		time	11:32				
@precip.	measured		@precip.	measured		@precip.	measured		@precip.	measured		@precip.	measured		@precip.	result	
mm/h	deviation		mm/h	deviation		mm/h	deviation		mm/h	deviation		mm/h	deviation		mm/h	deviation	
2	2.1	-2.6%	I	2.1	0.2%	O	2.1	-11.5%	O	2.1	-8.5%	I	2.1	-10.2%	I	2.1	-7.1%
20	19.4	-2.0%	O	19.8	-6.3%	I	19.7	-10.8%	O	19.8	-7.9%	I	19.9	-7.5%	I	19.8	-7.2%
50	53.5	-3.1%	O	53.3	-7.7%	I	53.6	-6.1%	I	53.2	-7.6%	I	52.7	-8.7%	O	53.4	-7.2%
90	95.2	-2.0%	O	97.7	-6.1%	I	95.4	-4.7%	I	95.0	-7.1%	I	96.0	-8.4%	O	96.1	-6.0%
130	134.6	-4.4%	O	137.2	-7.5%	I	134.6	-4.8%	I	134.6	-9.1%	O	134.6	-8.5%	I	135.4	-6.9%
170	176.3	-6.0%	I	179.6	-8.4%	I	176.3	-5.8%	O	177.0	-10.5%	O	176.7	-10.0%	I	177.5	-8.1%
200	208.1	-7.0%	I	212.2	-8.6%	I	208.3	-6.0%	O	209.0	-11.6%	O	208.9	-10.9%	I	209.8	-8.8%
271	268.5	-6.0%	I	267.2	-6.7%	O	266.5	-5.5%	I	252.6	-4.8%	I	264.8	-2.6%	O	262.6	-5.4%
368	364.1	-7.3%	I	360.7	-8.9%	O	360.8	-8.0%	I	359.2	-2.9%	O	340.1	-5.0%	I	355.0	-6.8%
500	509.9	-1.1%	I	498.8	-2.8%	O	507.0	-1.6%	I	499.4	1.6%	I	491.3	4.5%	O	505.4	-0.3%
Tamb	23.1		Tamb	23.5		Tamb	23.2		Tamb	22.2		Tamb	22.1				
Twater	20.0		Twater	21.0		Twater	20.5		Twater	19.5		Twater	19.8				
RelHum	36.7		RelHum	32.7		RelHum	38.9		RelHum	37.5		RelHum	37.1				
QNH	1018		QNH	1017		QNH	1013		QNH	1013		QNH	1013				
date	23/03/05		date	23/03/05		date	24/03/05		date	29/03/05		date	29/03/05				
time	11:40		time	15:45		time	11:31		time	07:29		time	06:57				

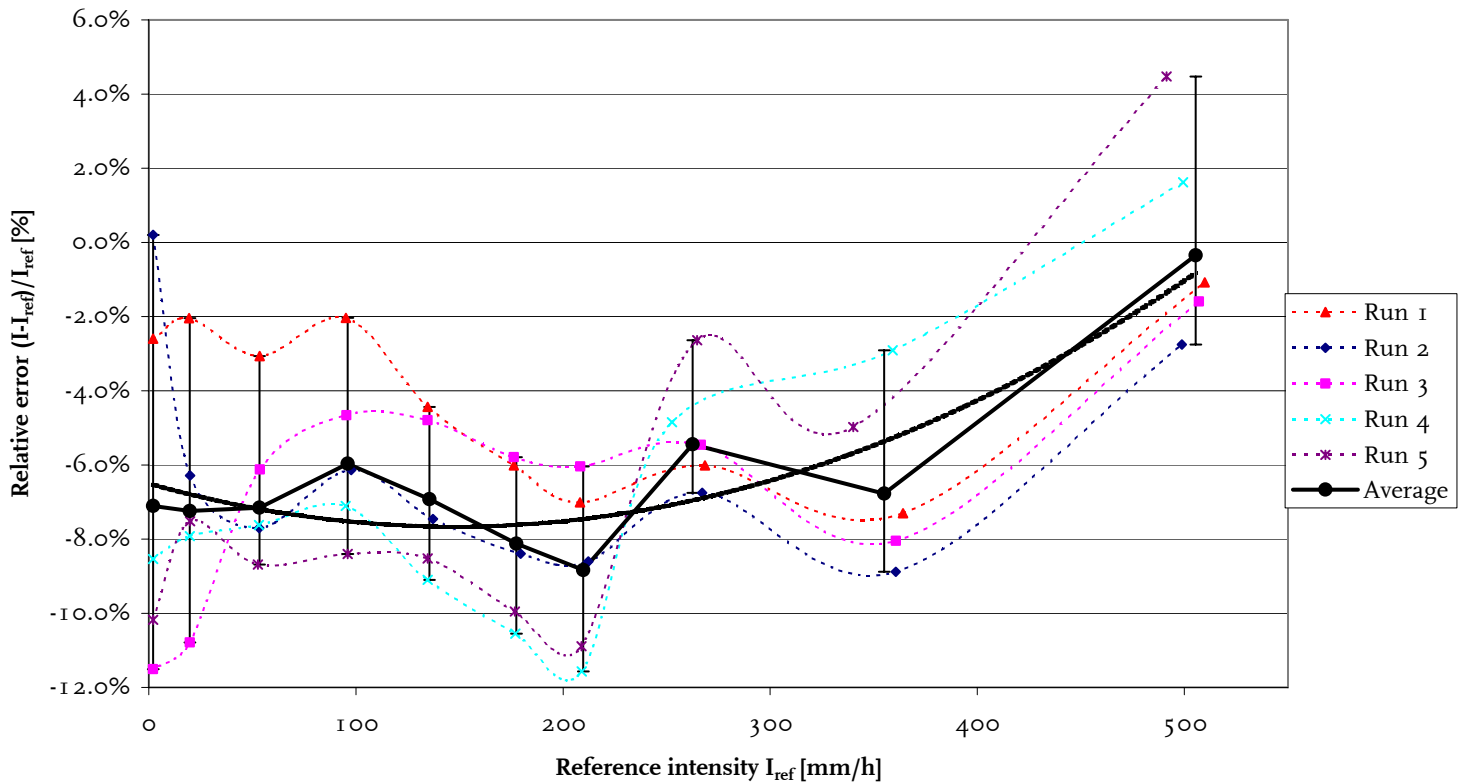

## Appendix 7: VRG101

Overview of the sensor results derived from reported intensity versus the reference and between the 2 instruments for the precipitation accumulation results. The coefficients of the polynomial fit and the power law fit are reported and the standard error after correction.

Parameter description	Sensor		
	A1	A2	Combined
Average within WMO range (mm/h)	2-928	20-928	
Standard error sensor 1 versus 2	-	-	2.12%
R <sup>2</sup> measured versus reference	0.9993	0.9994	0.9993
Standard error measured versus reference	3.01%	4.08%	3.58%
Polynomial fit to error a	2.30E-09	-1.05E-08	-3.69E-09
Error in a	1.38E-08	2.42E-08	1.44E-08
Polynomial fit to error b	0.0000	0.0001	0.0001
Error in b	0.0000	0.0000	0.0000
Polynomial fit to error c	-0.018	-0.042	-0.030
Error in c	0.006	0.011	0.007
Polynomial fit to error R <sup>2</sup>	0.8575	0.7281	0.7252
Standard error after correction	1.15%	2.00%	1.87%
Power law fit a	0.938	0.899	0.918
Error in a	0.015	0.014	0.011
Power law fit b	1.018	1.018	1.016
Error in b	0.003	0.003	0.002
Power law fit R <sup>2</sup>	0.9997	0.9997	0.9995
Standard error measured versus power law	1.59%	1.62%	2.12%

Summary of the average and standard deviation of the running 1-minute averaged reference and measured intensities for all 5 tests.

Reference intensity [mm/h]		A1 intensity [mm/h]		Reference intensity [mm/h]		A2 intensity [mm/h]	
Average	Std. Dev.	Average	Std. Dev.	Average	Std. Dev.	Average	Std. Dev.
1.92	0.09	1.86	0.93	1.94	0.27	1.74	1.11
21.58	2.66	21.36	2.59	23.24	0.27	22.68	0.55
42.81	14.59*	42.27	14.36	50.74	0.41	49.63	0.55
87.83	1.73	84.66	9.38	88.04	0.58	85.90	1.26
131.17	0.54	130.22	1.04	132.08	0.95	128.96	1.21
168.45	0.64	167.48	1.13	170.45	1.29	166.65	1.47
199.83	2.21	198.88	1.39	202.82	1.56	198.88	2.61
423.97	13.83**	429.11	26.36	433.14	2.51	424.90	3.36
915.91	9.08	927.60	51.50	917.01	32.99	930.82	59.13
1997.01	79.95	2144.87	110.39	1984.10	45.77	2103.93	51.83

\* During run 2 the reference intensity was only 14 mm/h instead of 50 mm/h.

\*\* The water ran out at the end of the reference intensity of 431 mm/h of run 3.

1			2			3			4			5			Intensity		
VRG <sub>IOI</sub>			VRG <sub>IOI</sub>			VRG <sub>IOI</sub>			VRG <sub>IOI</sub>			VRG <sub>IOI</sub>					
run #1			run #2			run #3			run #4			run #5					
Ser.nr AI			Ser.nr AI			Ser.nr AI			Ser.nr AI			Ser.nr AI					
Tamb	21.0		Tamb	22.4		Tamb	21.6		Tamb	22.7		Tamb	22.2				
Twater	16.0		Twater	17.5		Twater	19.2		Twater	19.8		Twater	19.2				
RelHum	37.0		RelHum	38.0		RelHum	37.0		RelHum	35.0		RelHum	30.0				
QNH	1017		QNH	1017		QNH	1016		QNH	1016		QNH	1008				
date	29/11/04		date	29/11/04		date	30/11/04		date	30/11/04		date	01/12/04				
time	09:38		time	12:17		time	09:22		time	13:36		time	08:22				
@precip.	measured		@precip.	measured		@precip.	measured		@precip.	measured		@precip.	measured		@precip.	result	
mm/h	deviation		mm/h	deviation		mm/h	deviation		mm/h	deviation		mm/h	deviation		mm/h	deviation	
2	1.9	-3.6%	I	1.9	-13.2%	O	1.9	-4.3%	I	2.0	-6.2%	I	1.9	10.3%	O	1.9	-4.7%
20	23.0	-0.9%	I	16.3	0.7%	O	22.8	-1.2%	I	23.0	-0.1%	I	22.8	-3.0%	O	22.9	-0.7%
50	49.7	-2.1%	O	13.6	0.0%	O	50.3	-1.0%	I	50.2	-1.1%	I	50.1	-1.0%	I	50.2	-1.0%
90	87.5	-1.2%	I	87.6	-1.1%	I	88.8	-1.1%	I	87.1	-14.3%	O	88.6	-1.0%	O	88.0	-1.1%
130	131.0	-0.9%	I	131.7	-0.8%	I	131.1	0.2%	O	130.8	-1.0%	I	131.3	-1.2%	O	131.2	-0.9%
170	167.5	-0.7%	I	168.9	-0.6%	I	168.1	0.2%	O	168.5	-0.9%	O	169.2	-0.8%	I	168.5	-0.7%
200	199.4	-0.8%	I	201.9	-1.0%	O	195.8	1.3%	O	201.2	-0.9%	I	200.5	-0.8%	I	200.4	-0.8%
431	424.9	-0.5%	I	430.4	4.5%	I	400.9	4.7%	O	428.8	-0.5%	I	429.4	-0.6%	O	428.0	1.2%
928	921.4	-1.4%	I	909.3	6.1%	I	928.2	-1.5%	I	910.8	6.9%	O	908.9	-3.6%	O	919.6	1.1%
2000	2067.3	7.5%	I	2034.9	8.0%	O	2046.2	7.9%	I	1982.1	8.0%	I	1852.6	5.5%	O	2031.9	7.8%
Tamb	17.5		Tamb	22.6		Tamb	22.7		Tamb	23.1		Tamb	23.1				
Twater	22.2		Twater	19.5		Twater	19.8		Twater	20.0		Twater	18.8				
RelHum	38.0		RelHum	38.0		RelHum	35.0		RelHum	32.0		RelHum	30.0				
QNH	1017		QNH	1017		QNH	1016		QNH	1014		QNH	1008				
date	29/11/04		date	29/11/04		date	30/11/04		date	30/11/04		date	01/12/04				
time	12:04		time	15:46		time	13:26		time	16:26		time	11:15				

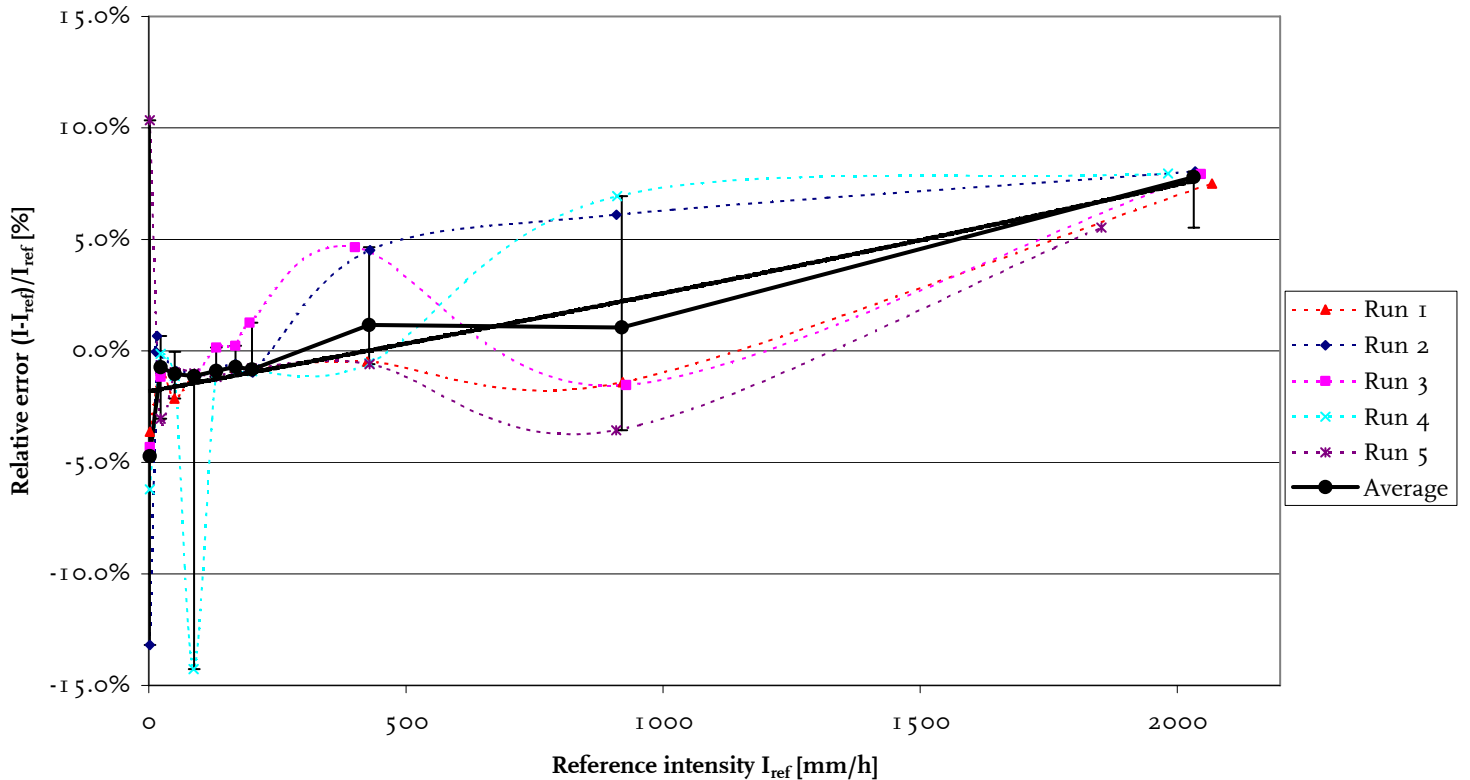

1			2			3			4			5			Intensity		
VRG <sub>IOI</sub>			VRG <sub>IOI</sub>			VRG <sub>IOI</sub>			VRG <sub>IOI</sub>			VRG <sub>IOI</sub>					
run	#1		run	#2		run	#3		run	#4		run	#5				
Ser.nr	A2		Ser.nr	A2		Ser.nr	A2		Ser.nr	A2		Ser.nr	A2				
Tamb	22.1		Tamb	21.8		Tamb	22.6		Tamb	22.0		Tamb	22.0				
Twater	19.0		Twater	18.2		Twater	20.0		Twater	20.1		Twater	20.0				
RelHum	38.6		RelHum	36.0		RelHum	43.0		RelHum	38.0		RelHum	38.0				
QNH	1007		QNH	1024		QNH	1023		QNH	1011		QNH	1011				
date	10/11/04		date	15/11/04		date	16/11/04		date	18/11/04		date	18/11/04				
time	13:27		time	12:40		time	14:44		time	12:31		time	13:04				
@precip.	measured		@precip.	measured		@precip.	measured		@precip.	measured		@precip.	measured		@precip.	result	
mm/h	deviation		mm/h	deviation		mm/h	deviation		mm/h	deviation		mm/h	deviation		mm/h	deviation	
2	2.0	-8.8%	I	1.9	-2.9%	O	1.8	-22.0%	O	2.0	-7.0%	I	2.0	-12.5%	I	2.0	-9.4%
20	23.3	-2.0%	O	23.4	-2.3%	I	23.2	-2.4%	I	23.1	-3.0%	O	23.1	-2.3%	I	23.3	-2.3%
50	50.5	-1.8%	O	50.5	-1.8%	I	50.5	-2.2%	I	50.8	-2.4%	I	51.2	-2.4%	O	50.6	-2.1%
90	88.3	-2.6%	I	88.1	-2.1%	I	88.6	-2.7%	I	87.9	-2.9%	O	87.3	-1.7%	O	88.3	-2.5%
130	132.1	-2.4%	I	132.2	-2.5%	O	133.5	-2.2%	O	131.7	-2.4%	I	130.9	-2.4%	I	131.6	-2.4%
170	170.2	-2.2%	I	170.6	-2.3%	I	172.6	-2.2%	I	169.9	-2.0%	O	169.0	-2.4%	O	171.1	-2.2%
200	202.8	-2.1%	I	203.8	-1.2%	O	204.9	-2.2%	O	202.2	-2.1%	I	200.5	-2.1%	I	201.8	-2.1%
431	432.3	-1.9%	I	434.2	-1.9%	I	436.6	-1.8%	O	433.0	-1.8%	I	429.3	-2.0%	O	433.2	-1.9%
928	914.8	5.9%	O	897.2	-1.6%	I	896.4	-1.8%	O	980.4	0.9%	I	895.6	4.2%	I	924.4	1.2%
2000	2036.3	4.1%	O	1997.4	7.1%	I	1906.6	7.3%	O	1990.6	5.5%	I	1984.4	6.6%	I	1990.8	6.4%
Tamb	22.8		Tamb	23.2		Tamb	22.6		Tamb	22.2		Tamb	22.4				
Twater	20.2		Twater	19.0		Twater	19.4		Twater	19.0		Twater	19.4				
RelHum	37.0		RelHum	41.0		RelHum	41.0		RelHum	30.0		RelHum	30.0				
QNH	1010		QNH	1012		QNH	1012		QNH	1033		QNH	1032				
date	18/11/04		date	22/11/04		date	22/11/04		date	24/11/04		date	24/11/04				
time	14:12		time	14:21		time	16:36		time	13:29		time	15:39				

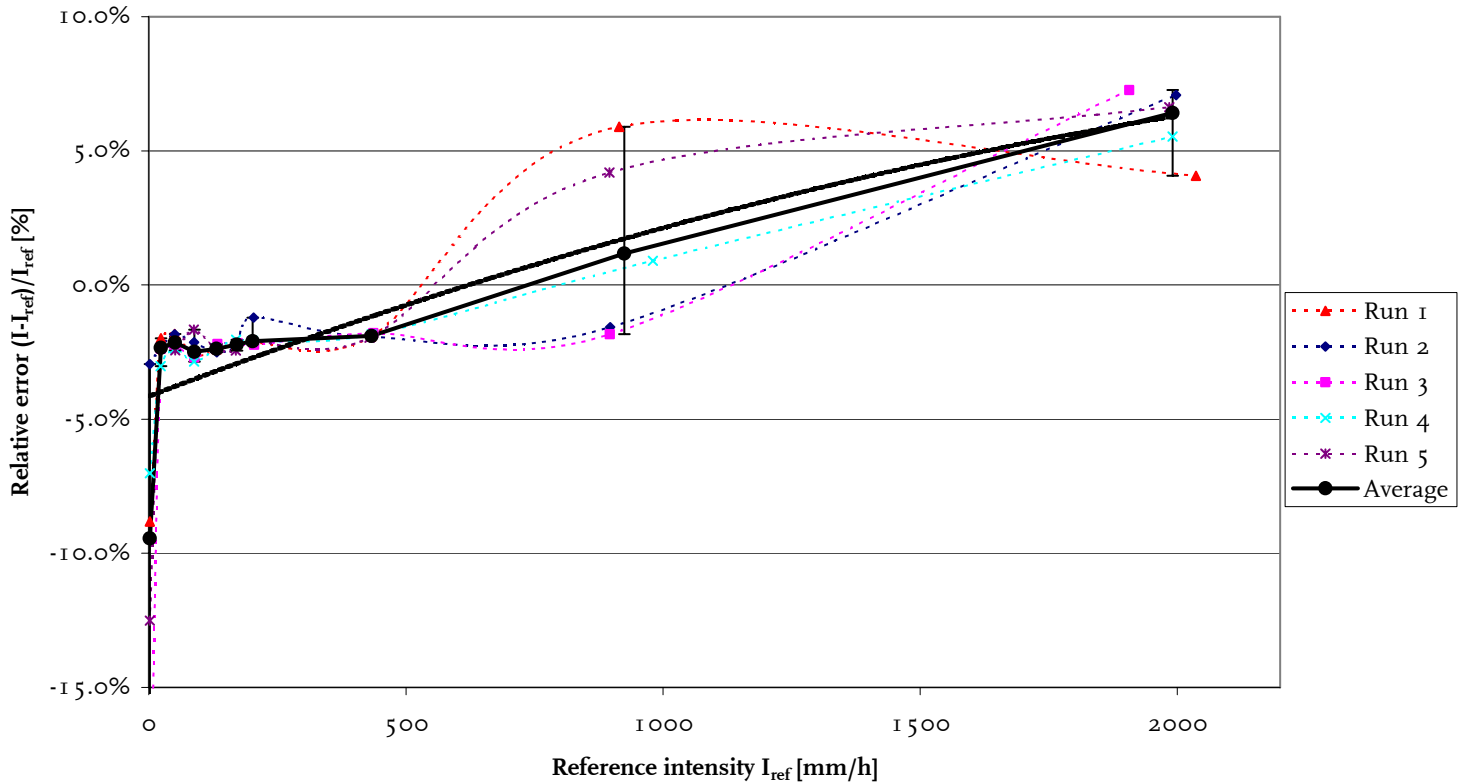

## Appendix 8: Nilometre

Overview of the sensor results derived from reported accumulated amount versus the reference and between the 2 instruments for the precipitation accumulation results. The coefficients of the polynomial fit and the power law fit are reported and the standard error after correction.

Parameter description	Sensor		
	040601	040602	Combined
Average within WMO range (mm/h)	2-200	2, 90-200	
Standard error sensor 1 versus 2	-	-	2.31%
R <sup>2</sup> measured versus reference	0.9997	0.9999	0.9997
Standard error measured versus reference	1.95%	3.76%	2.99%
Polynomial fit to error a	-4.19E-07	-6.18E-07	-5.23E-07
Error in a	9.09E-07	8.22E-07	9.10E-07
Polynomial fit to error b	0.0000	0.0002	0.0001
Error in b	0.0002	0.0002	0.0002
Polynomial fit to error c	-0.015	-0.045	-0.030
Error in c	0.008	0.007	0.008
Polynomial fit to error R <sup>2</sup>	0.2259	0.3097	0.0291
Standard error after correction	0.77%	0.71%	1.29%
Power law fit a	0.993	0.954	0.973
Error in a	0.009	0.009	0.010
Power law fit b	1.003	1.003	1.000
Error in b	0.002	0.002	0.002
Power law fit R <sup>2</sup>	0.9999	0.9999	0.9997
Standard error measured versus power law	0.76%	0.76%	1.66%

Summary of the average and standard deviation of the running 1-minute averaged reference and measured intensities for all 5 tests.

Reference intensity [mm/h]		040601 intensity [mm/h]		Reference intensity [mm/h]		040602 intensity [mm/h]	
Average	Std. Dev.	Average	Std. Dev.	Average	Std. Dev.	Average	Std. Dev.
1.97	0.11	1.94	1.73	1.94	0.10	1.78	1.50
20.48	0.13	19.45	7.81	20.49	0.14	19.19	8.67
53.52	0.49	51.03	28.39	53.38	0.52	49.39	25.78
98.54	0.53	90.27	72.42	98.57	0.63	96.30	65.36
140.13	0.78	133.20	106.85	140.68	1.23	124.80	104.20
179.80	1.05	169.28	170.92	180.30	1.31	165.81	167.98
211.72	1.24	187.59	202.85	212.47	1.67	196.16	201.29

1			2			3			4			5			Intensity		
Nilometre			Nilometre			Nilometre			Nilometre			Nilometre					
run	#1		run	#2		run	#3		run	#4		run	#5				
Ser.nr	40601		Ser.nr	40601		Ser.nr	40601		Ser.nr	40601		Ser.nr	40601				
Tamb	23.3		Tamb	23.6		Tamb	23.8		Tamb	23.6		Tamb	22.8				
Twater	22.0		Twater	22.0		Twater	22.0		Twater	22.0		Twater	22.2				
RelHum	48.6		RelHum	49.0		RelHum	48.7		RelHum	42.3		RelHum	44.3				
QNH	1015		QNH	1016		QNH	1016		QNH	1017		QNH	1014				
date	26/09/05		date	26/09/05		date	26/09/05		date	26/09/05		date	27/09/05				
time	07:08		time	09:03		time	10:23		time	13:28		time	06:00				
@precip.	measured		@precip.	measured		@precip.	measured		@precip.	measured		@precip.	measured		@precip.	result	
mm/h	deviation		mm/h	deviation		mm/h	deviation		mm/h	deviation		mm/h	deviation		mm/h	deviation	
2	2.0	-0.8%	I	1.9	-19.6%	O	1.9	2.6%	I	1.9	6.4%	I	2.0	14.0%	O	2.0	2.7%
20	20.6	-9.4%	O	20.4	-0.7%	I	20.4	-1.9%	I	20.5	-2.6%	I	20.6	1.0%	O	20.4	-1.7%
50	53.9	-4.4%	O	53.2	-1.6%	I	52.7	-2.6%	I	53.9	-1.0%	I	53.0	-0.4%	O	53.3	-1.7%
90	98.9	-2.0%	I	98.2	-2.2%	I	98.9	-1.4%	I	99.0	-0.8%	O	97.8	-2.9%	O	98.7	-1.9%
130	140.8	-1.5%	I	139.7	-2.0%	O	140.7	-0.7%	I	140.6	0.4%	I	138.8	1.7%	O	140.7	-0.6%
170	180.8	-0.9%	I	179.4	0.1%	O	180.8	-1.5%	O	180.4	-0.2%	I	178.0	-0.5%	I	179.7	-0.5%
200	213.5	-3.0%	I	211.0	-1.6%	I	212.2	-17.6%	O	212.1	-1.2%	O	210.0	-5.3%	I	211.5	-3.3%
Tamb	23.5		Tamb	24.0		Tamb	23.5		Tamb	23.1		Tamb	23.7				
Twater	22.0		Twater	22.0		Twater	22.0		Twater	22.0		Twater	21.6				
RelHum	48.7		RelHum	42.9		RelHum	42.9		RelHum	42.5		RelHum	43.3				
QNH	1016		QNH	1017		QNH	1017		QNH	1017		QNH	1014				
date	26/09/05		date	26/09/05		date	26/09/05		date	26/09/05		date	27/09/05				
time	08:58		time	12:40		time	13:22		time	15:37		time	09:22				

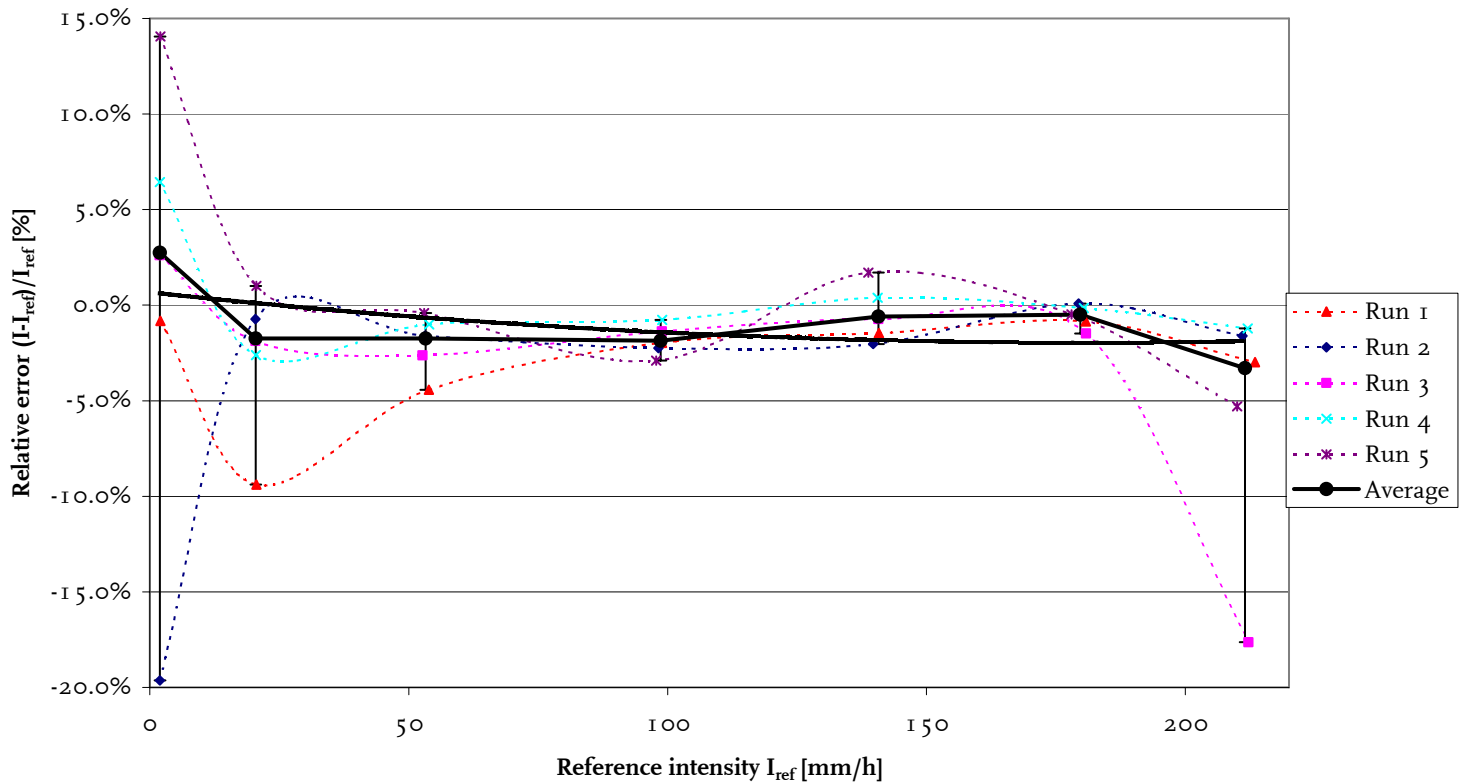



## Appendix 9: Pluvio 250

Overview of the sensor results derived from the reported intensity versus the reference and between the 2 instruments for the precipitation accumulation results. The coefficients of the polynomial fit and the power law fit are reported and the standard error after correction.

Parameter description	Sensor		
	198264	198265	Combined
Average within WMO range (mm/h)	2-50, 90-1200	20-1200	
Standard error sensor 1 versus 2	-	-	3.20%
R <sup>2</sup> measured versus reference	0.9998	1.0000	0.9999
Standard error measured versus reference	3.11%	1.79%	2.54%
Polynomial fit to error a	-3.77E-08	-5.40E-08	-4.56E-08
Error in a	8.92E-08	4.36E-08	4.87E-08
Polynomial fit to error b	0.0000	0.0001	0.0001
Error in b	0.0001	0.0001	0.0001
Polynomial fit to error c	0.005	-0.019	-0.007
Error in c	0.019	0.009	0.010
Polynomial fit to error R <sup>2</sup>	0.0259	0.2679	0.0563
Standard error after correction	2.91%	1.42%	2.47%
Power law fit a	0.991	0.956	0.973
Error in a	0.029	0.010	0.015
Power law fit b	1.008	1.008	1.006
Error in b	0.006	0.002	0.003
Power law fit R <sup>2</sup>	1.0000	1.0000	0.9999
Standard error measured versus power law	2.87%	0.98%	2.47%

Summary of the average and standard deviation of the running 1-minute averaged reference and measured intensities for all 5 tests.

Reference intensity [mm/h]		198264 intensity [mm/h]		Reference intensity [mm/h]		198265 intensity [mm/h]	
Average	Std. Dev.	Average	Std. Dev.	Average	Std. Dev.	Average	Std. Dev.
2.33	0.20	2.29	0.30	2.31	0.20	2.18	0.29
21.07	0.22	21.02	0.53	20.74	0.30	20.61	0.32
50.34	0.40	50.28	0.57	49.71	0.45	49.52	0.56
94.93	1.15	102.55	12.99*	94.74	1.47	94.66	1.45
138.75	0.84	139.02	3.67	138.49	0.83	138.36	1.21
177.26	1.36	177.19	2.06	177.08	0.87	176.79	2.30
213.41	1.24	213.41	2.18	213.74	1.53	213.02	4.18
380.25	1.92	380.03	3.06	382.00	4.04	384.87	19.82*
652.08	5.25	676.03	65.63*	648.99	22.23**	650.43	39.96
1217.47	21.70	1215.51	23.34	1221.86	26.56	1220.61	30.30

\* At 90, 363 and 660 mm/h the sensor delay was sometimes larger than 8 minutes.

\*\* During run 1 and 4 the reference intensity was about 620 instead of 660 mm/h.

1			2			3			4			5			Intensity	
Pluvio 1			Pluvio 2			Pluvio 3			Pluvio 4			Pluvio 5				
run	#1		run	#2		run	#3		run	#4		run	#5			
Ser.nr	198264		Ser.nr	198264		Ser.nr	198264		Ser.nr	198264		Ser.nr	198264			
Tamb	25.5		Tamb	24.7		Tamb	26.6		Tamb	26.0		Tamb	24.3			
Twater	23.2		Twater	23.3		Twater	23.0		Twater	23.0		Twater	22.1			
RelHum	39.9		RelHum	46.0		RelHum	43.7		RelHum	46.9		RelHum	59.7			
QNH	1018		QNH	1010		QNH	1009		QNH	1008		QNH	1005			
date	28/06/05		date	29/06/05		date	29/06/05		date	30/06/05		date	04/07/05			
time	11:44		time	08:27		time	13:08		time	10:41		time	07:24			
@precip.	measured		@precip.	measured		@precip.	measured		@precip.	measured		@precip.	measured		@precip.	result
mm/h	deviation		mm/h	deviation		mm/h	deviation		mm/h	deviation		mm/h	deviation		mm/h	deviation
2	2.3	-1.3% I	2.4	-2.9% O		2.4	-2.9% I		2.3	-2.1% I		2.2	1.2% O		2.3	-2.1% I
20	20.9	-0.1% I	21.1	-0.5% O		21.1	-0.1% O		21.3	-0.4% I		21.0	-0.2% I		21.1	-0.2% I
50	49.8	-0.2% O	50.2	0.0% I		50.5	0.1% O		50.8	0.0% I		50.5	-0.1% I		50.5	-0.1% I
90	94.2	12.0% O	93.6	10.2% I		96.3	0.3% O		95.9	8.5% I		95.0	9.1% I		94.8	9.3% I
130	138.2	0.1% I	138.4	0.2% I		137.8	0.2% I		139.9	0.7% O		139.2	-0.2% O		138.1	0.2% I
170	177.1	-0.2% I	176.4	-0.1% I		175.5	-0.2% O		179.2	0.1% O		178.2	0.0% I		177.2	-0.1% I
200	212.9	-0.3% O	212.6	-0.1% I		212.0	0.1% I		215.0	0.1% I		214.6	0.3% O		213.2	0.0% I
363	378.4	-0.1% I	379.5	-0.3% O		379.5	0.0% O		383.2	-0.1% I		381.7	0.0% I		381.1	-0.1% I
660	659.8	-0.4% O	653.2	0.3% I		644.5	6.6% I		648.8	10.5% O		653.7	0.7% I		650.4	2.5% I
1200	1216.6	0.0% I	1214.1	-0.2% I		1202.1	0.2% O		1196.0	-0.2% O		1257.0	0.0% I		1229.2	-0.1% I
Tamb	24.6		Tamb	26.6		Tamb	25.8		Tamb	26.2		Tamb	25.4			
Twater	23.2		Twater	24.0		Twater	24.0		Twater	24.4		Twater	23.3			
RelHum	46.0		RelHum	43.8		RelHum	47.6		RelHum	48.0		RelHum	55.8			
QNH	1010		QNH	1009		QNH	1008		QNH	1007		QNH	1001			
date	29/06/05		date	29/06/05		date	30/06/05		date	30/06/05		date	04/07/05			
time	08:18		time	13:06		time	10:33		time	15:15		time	12:13			

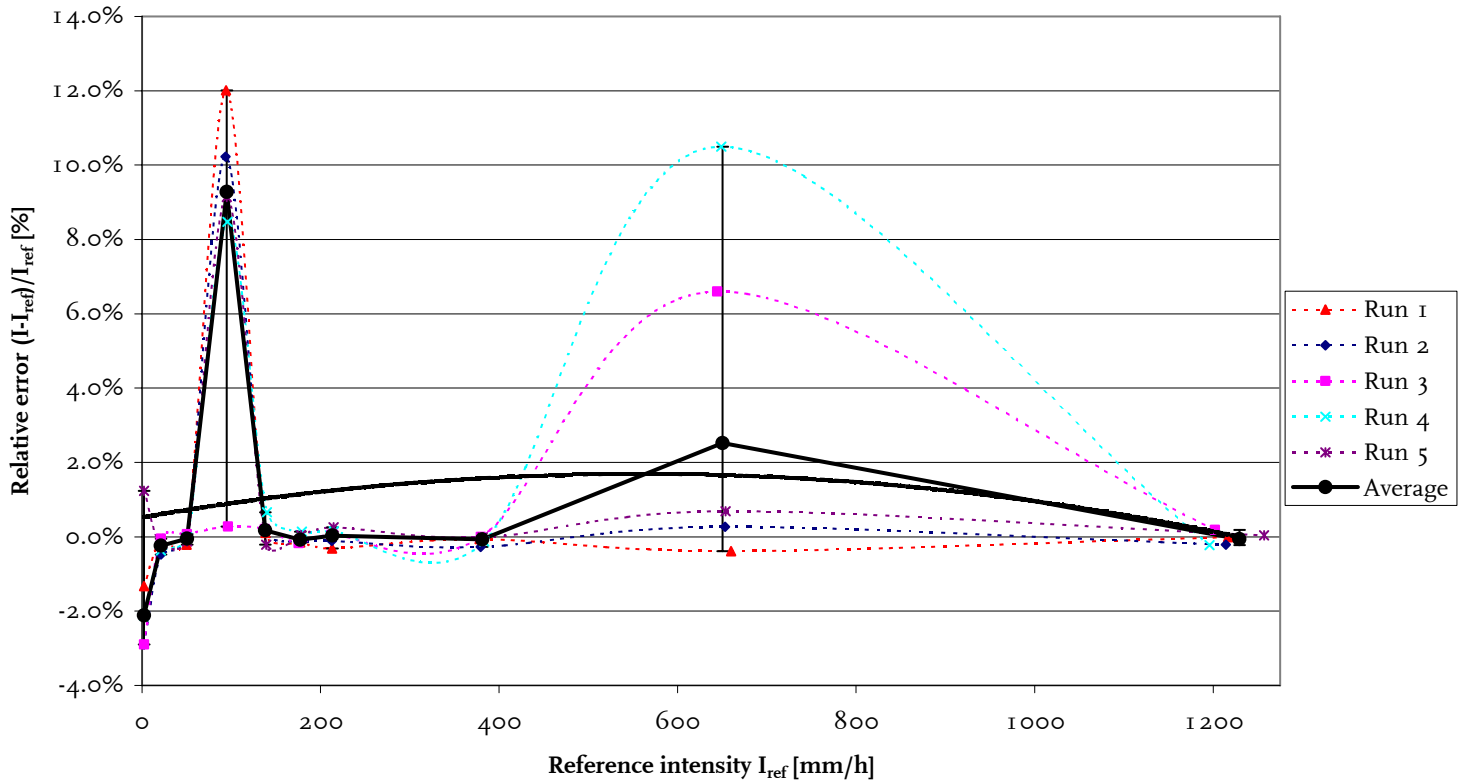

1			2			3			4			5			Intensity		
Pluvio 1			Pluvio 2			Pluvio 3			Pluvio 4			Pluvio 5					
run	#1		run	#2		run	#3		run	#4		run	#5				
Ser.nr	198265		Ser.nr	198265		Ser.nr	198265		Ser.nr	198265		Ser.nr	198265				
Tamb	26.2		Tamb	28.1		Tamb	28.4		Tamb	25.4		Tamb	23.7				
Twater	24.4		Twater	25.2		Twater	24.8		Twater	23.0		Twater	23.8				
RelHum	44.1		RelHum	37.0		RelHum	45.4		RelHum	37.9		RelHum	41.6				
QNH	1020		QNH	1019		QNH	1014		QNH	1023		QNH	1020				
date	23/06/05		date	23/06/05		date	24/06/05		date	27/06/05		date	28/06/05				
time	06:44		time	12:23		time	08:16		time	10:13		time	06:22				
@precip.	measured		@precip.	measured		@precip.	measured		@precip.	measured		@precip.	measured		@precip.	result	
mm/h	deviation		mm/h	deviation		mm/h	deviation		mm/h	deviation		mm/h	deviation		mm/h	deviation	
2	2.3	-7.4%	I	2.4	-5.9%	I	2.3	-9.7%	O	2.2	-3.5%	I	2.3	-2.1%	O	2.3	-5.6%
20	20.7	-0.4%	I	20.5	-0.5%	I	20.9	-1.2%	O	21.1	-1.1%	I	20.6	-0.1%	O	20.7	-0.6%
50	49.7	-0.4%	I	49.3	-0.4%	I	49.9	-0.5%	O	50.4	-0.3%	I	49.3	-0.2%	O	49.8	-0.4%
90	94.8	0.0%	I	94.6	-0.4%	O	96.9	0.0%	I	92.2	0.6%	O	94.6	0.1%	I	95.4	0.0%
130	138.8	0.1%	O	138.9	-0.1%	I	139.4	-0.1%	O	137.4	-0.1%	I	137.9	-0.1%	I	138.0	-0.1%
170	177.9	0.0%	O	177.4	-0.1%	I	177.5	-0.1%	I	175.7	-0.2%	I	176.9	-0.4%	O	176.9	-0.1%
200	215.0	-1.0%	O	213.2	0.0%	O	215.7	-0.4%	I	212.2	-0.4%	I	213.3	-0.1%	I	213.7	-0.3%
363	381.3	0.0%	I	387.7	3.9%	O	384.9	-0.1%	I	376.4	-0.1%	O	379.4	0.0%	I	381.9	0.0%
660	621.6	0.1%	I	669.4	0.3%	I	674.2	2.2%	O	623.9	-0.3%	I	654.4	-1.1%	O	638.3	0.0%
1200	1217.4	-0.4%	O	1238.6	0.1%	I	1254.4	0.1%	O	1175.9	-0.2%	I	1221.9	0.0%	I	1212.1	-0.1%
Tamb	27.9		Tamb	28.4		Tamb	25.3		Tamb	25.9		Tamb	25.1				
Twater	25.1		Twater	24.8		Twater	23.0		Twater	23.7		Twater	23.2				
RelHum	37.5		RelHum	45.4		RelHum	38.1		RelHum	35.8		RelHum	39.1				
QNH	1019		QNH	1014		QNH	1023		QNH	1021		QNH	1018				
date	23/06/05		date	24/06/05		date	27/06/05		date	27/06/05		date	28/06/05				
time	11:40		time	08:13		time	10:11		time	15:13		time	11:14				

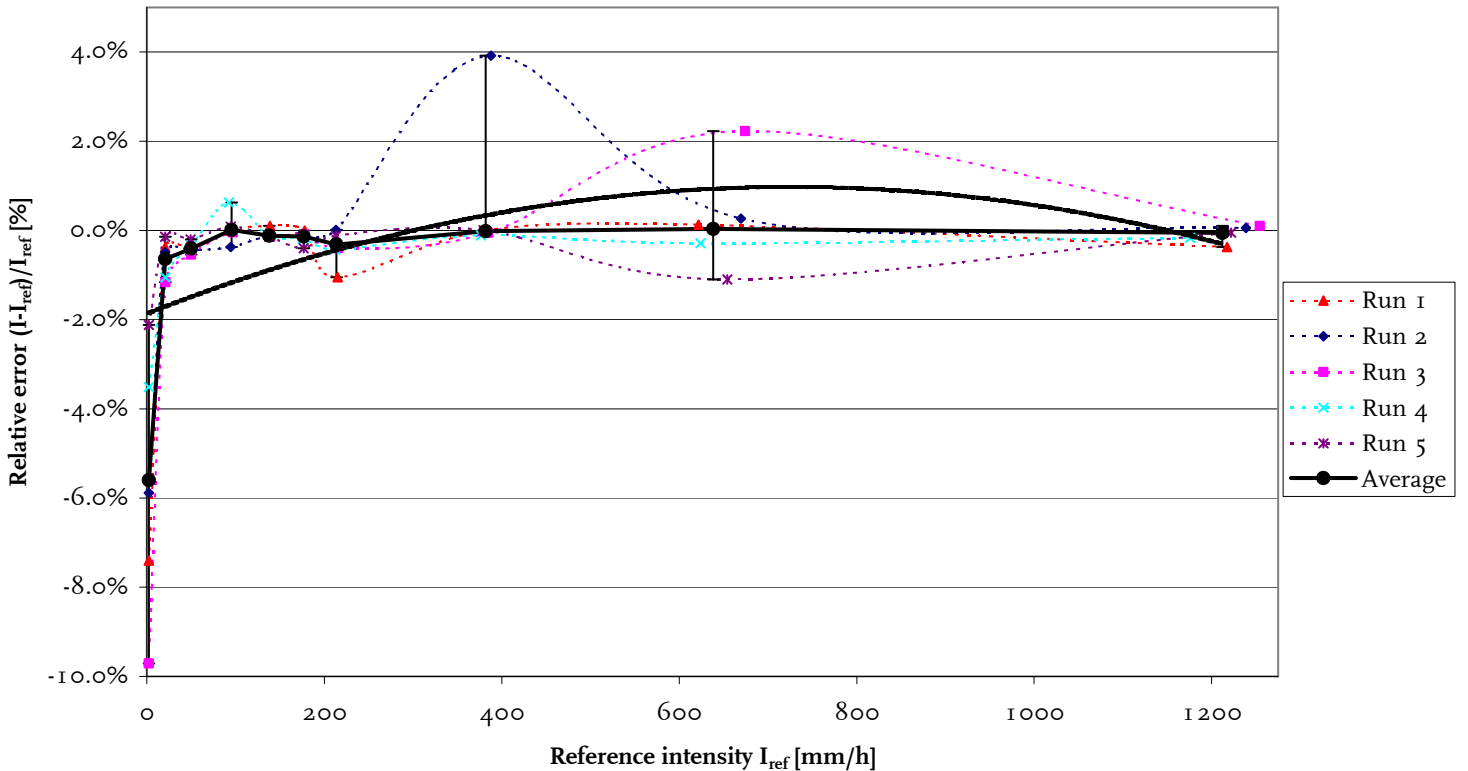

## Appendix 10: India Meteorology Dept. TBRG Mk2

Overview of the sensor results derived from tips versus the reference and between the 2 instruments. The coefficients of the polynomial fit and the power law fit are reported and the standard error after correction.

Parameter description	Sensor		
	1-2004	2-2004	Combined
Average within WMO range (mm/h)	2-90	2-50	-
Standard error sensor 1 versus 2	-	-	0.86%
R <sup>2</sup> measured versus reference	0.9991	0.9988	0.9989
Standard error measured versus reference	9.59%	9.93%	9.76%
Polynomial fit to error a	5.43E-08	4.06E-08	4.74E-08
Error in a	7.42E-09	5.92E-09	5.21E-09
Polynomial fit to error b	-0.0002	-0.0002	-0.0002
Error in b	0.0000	0.0000	0.0000
Polynomial fit to error c	-0.024	-0.036	-0.030
Error in c	0.004	0.003	0.003
Polynomial fit to error R <sup>2</sup>	0.9878	0.9909	0.9843
Standard error after correction	0.68%	0.55%	0.75%
Power law fit a	1.062	1.047	1.054
Error in a	0.036	0.034	0.023
Power law fit b	0.972	0.972	0.971
Error in b	0.007	0.006	0.004
Power law fit R <sup>2</sup>	0.9995	0.9995	0.9996
Standard error measured versus power law	3.39%	3.22%	3.33%

Summary of the average and standard deviation of the reference intensities and the time interval between consecutive tips for all 5 tests.

Reference intensity [mm/h]		1-2004 tip interval [s]		Reference intensity [mm/h]		2-2004 tip interval [s]	
Average	Std. Dev.	Average	Std. Dev.	Average	Std. Dev.	Average	Std. Dev.
2.25	0.65	854.66	20.58	2.27	0.70	851.98	18.83
20.38	1.27	90.28	4.49	19.57	0.99	96.00	4.21
43.67	2.22*	42.22	2.50	45.12	1.05	41.60	2.34
98.61	1.58	19.11	1.91	97.49	5.73**	19.51	2.23
140.60	1.59	13.53	2.28	140.53	1.82	13.65	2.22
182.44	2.20	10.58	1.60	181.98	2.13	10.65	1.69
211.45	3.47	9.18	1.85	210.84	2.39	9.22	1.84
416.18	4.47	4.88	0.53	436.35	5.01	4.77	0.73
995.75	6.64	2.23	0.39	998.69	24.69**	2.20	0.40
2081.02	13.27	1.09	0.12	2074.50	50.60	1.10	0.12

\* During 2 runs the reference intensity was lower.

\*\* During one run the reference intensity was not constant over the full period.

1			2			3			4			5			Tips		
TBRG Mk2			TBRG Mk2			TBRG Mk2			TBRG Mk2			TBRG Mk2					
run	#1		run	#2		run	#3		run	#4		run	#5				
Ser.nr	1-2004		Ser.nr	1-2004		Ser.nr	1-2004		Ser.nr	1-2004		Ser.nr	1-2004				
Tamb	22.1		Tamb	22.0		Tamb	21.7		Tamb	22.9		Tamb	22.4				
Twater	19.8		Twater	17.0		Twater	18.0		Twater	19.5		Twater	20.4				
RelHum	30.4		RelHum	30.7		RelHum	29.6		RelHum	25.6		RelHum	28.1				
QNH	1022		QNH	1017		QNH	1021		QNH	1022		QNH	1021				
date	13/05/05		date	17/05/05		date	18/05/05		date	18/05/05		date	19/05/05				
time	06:52		time	09:08		time	06:35		time	09:46		time	05:25				
@precip.	measured		@precip.	measured		@precip.	measured		@precip.	measured		@precip.	measured		@precip.	result	
mm/h	deviation		mm/h	deviation		mm/h	deviation		mm/h	deviation		mm/h	deviation		mm/h	deviation	
2	2.1	-2.5%	I	2.1	-2.9%	O	2.2	-2.4%	I	2.2	-1.8%	I	2.1	-1.6%	O	2.2	-2.2%
20	21.3	-0.9%	O	21.2	-1.8%	I	19.7	-2.7%	O	19.6	-2.3%	I	19.7	-2.0%	I	20.2	-2.0%
50	41.3	-1.2%	O	41.3	-1.6%	I	45.1	-2.6%	I	45.1	-3.0%	O	45.3	-2.9%	I	43.9	-2.4%
90	99.3	-3.5%	O	98.3	-4.6%	I	98.8	-5.0%	O	98.1	-4.8%	I	98.4	-4.7%	I	98.2	-4.7%
130	141.3	-5.1%	O	140.1	-5.3%	I	140.4	-5.8%	O	140.3	-5.4%	I	140.4	-5.5%	I	140.3	-5.4%
170	183.1	-7.0%	I	181.7	-6.3%	O	183.3	-7.6%	O	181.7	-6.8%	I	182.0	-6.5%	I	182.3	-6.7%
200	212.2	-7.6%	O	210.4	-7.2%	I	212.6	-7.6%	I	210.5	-7.3%	I	211.2	-7.2%	O	211.2	-7.4%
431	415.4	-8.8%	O	417.9	-8.9%	I	413.4	-10.2%	O	414.2	-10.0%	I	419.6	-9.7%	I	417.2	-9.5%
928	996.7	-16.2%	I	995.3	-16.1%	I	995.2	-16.1%	O	995.4	-16.1%	I	996.1	-16.5%	O	995.8	-16.1%
2000	2082.1	-19.9%	O	2085.2	-20.1%	I	2080.1	-20.0%	I	2077.4	-20.1%	I	2085.0	-20.2%	O	2080.9	-20.1%
Tamb	23.4		Tamb	23.4		Tamb	23.4		Tamb	23.0		Tamb	23.1				
Twater	20.8		Twater	20.8		Twater	20.8		Twater	18.0		Twater	19.0				
RelHum	28.1		RelHum	28.1		RelHum	28.1		RelHum	47.2		RelHum	49.4				
QNH	1019		QNH	1019		QNH	1019		QNH	1015		QNH	1014				
date	19/05/05		date	19/05/05		date	19/05/05		date	20/05/05		date	20/05/05				
time	12:49		time	12:49		time	12:49		time	08:00		time	08:41				

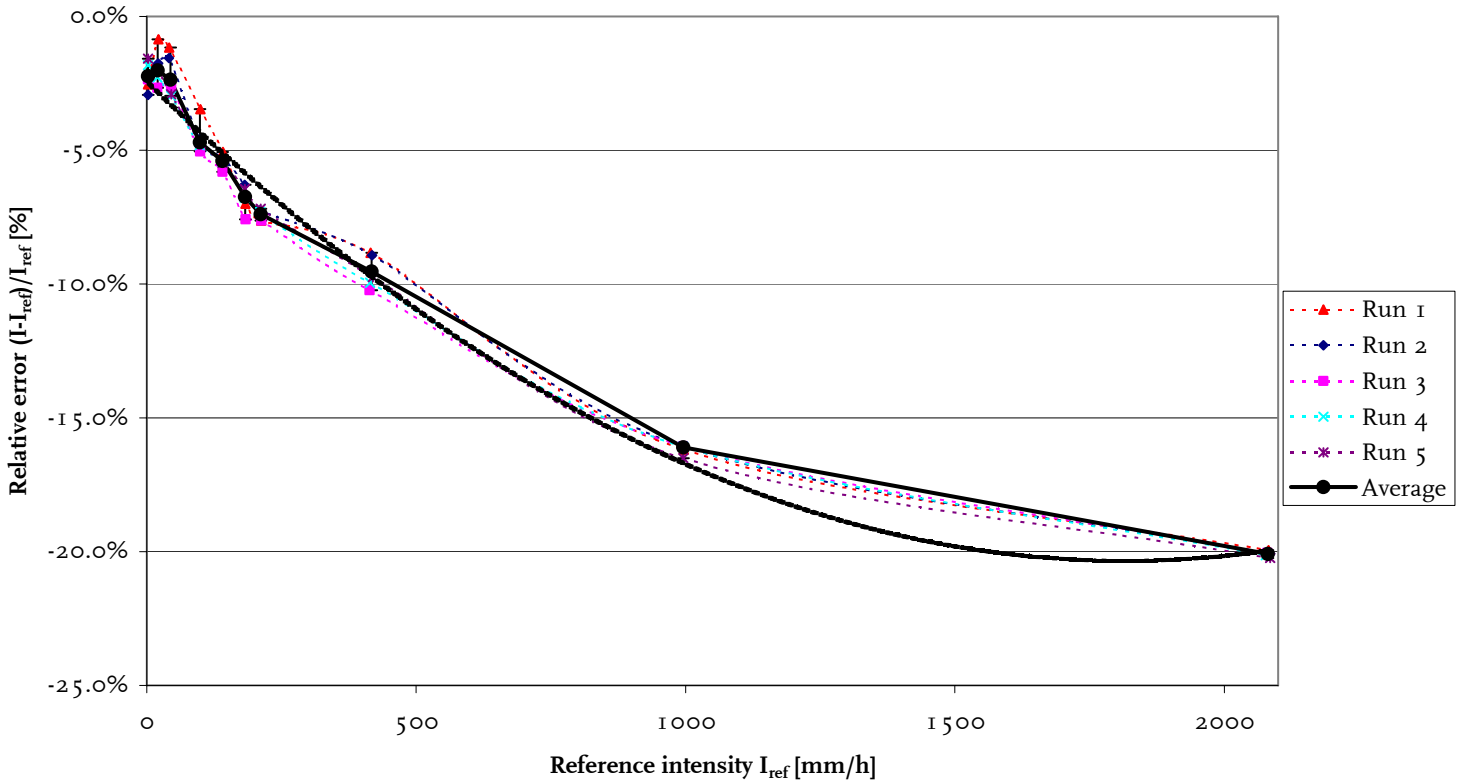

1			2			3			4			5			Tips		
TBRG Mk2			TBRG Mk2			TBRG Mk2			TBRG Mk2			TBRG Mk2					
run	#1		run	#2		run	#3		run	#		run	#5				
Ser.nr	2-2004		Ser.nr	2-2004		Ser.nr	2-2004		Ser.nr	2-2004		Ser.nr	2-2004				
Tamb	23.4		Tamb	23.3		Tamb	24.1		Tamb	23.8		Tamb	24.1				
Twater	20.0		Twater	20.0		Twater	20.8		Twater	20.0		Twater	21.0				
RelHum	49.9		RelHum	38.5		RelHum	34.4		RelHum	34.9		RelHum	37.0				
QNH	1014		QNH	1013		QNH	1015		QNH	1020		QNH	1020				
date	20/05/05		date	23/05/05		date	23/05/05		date	24/05/05		date	24/05/05				
time	09:36		time	06:43		time	09:49		time	07:14		time	10:07				
@precip.	measured		@precip.	measured		@precip.	measured		@precip.	measured		@precip.	measured		@precip.	result	
mm/h	deviation		mm/h	deviation		mm/h	deviation		mm/h	deviation		mm/h	deviation		mm/h	deviation	
2	2.2	-3.8%	o	2.2	-2.3%	o	2.2	-2.6%	I	2.2	-2.8%	I	2.2	-2.6%	I	2.2	-2.7%
20	19.5	-3.4%	I	19.5	-4.5%	I	19.5	-2.9%	o	19.4	-5.7%	o	19.6	-3.0%	I	19.5	-3.6%
50	45.0	-4.5%	o	45.1	-3.5%	o	45.1	-4.2%	I	44.8	-3.9%	I	45.3	-4.0%	I	45.1	-4.0%
90	98.8	-5.5%	I	96.7	-5.5%	I	97.4	-5.2%	I	98.3	-5.1%	o	96.4	-6.2%	o	97.6	-5.4%
130	141.1	-5.9%	o	140.6	-6.1%	I	140.5	-6.4%	I	140.6	-6.1%	I	139.7	-6.8%	o	140.6	-6.2%
170	182.6	-7.7%	o	182.4	-7.2%	I	181.9	-7.5%	I	182.1	-6.5%	o	180.7	-7.3%	I	181.7	-7.3%
200	211.6	-8.2%	o	211.5	-7.2%	I	211.4	-7.6%	I	209.8	-6.6%	o	209.8	-7.9%	I	210.9	-7.6%
431	434.5	-10.7%	o	437.5	-10.0%	I	437.8	-10.0%	I	434.1	-9.6%	o	438.2	-9.7%	I	437.8	-9.9%
928	1002.4	-15.9%	I	968.0	-12.1%	o	1006.3	-16.0%	o	1005.0	-15.4%	I	1011.4	-15.9%	I	1006.3	-15.7%
2000	2090.8	-21.0%	o	2011.8	-17.1%	o	2089.7	-20.4%	I	2083.1	-20.9%	I	2099.1	-20.6%	I	2090.6	-20.6%
Tamb	24.3		Tamb	23.9		Tamb	23.9		Tamb	23.8		Tamb	23.8				
Twater	21.8		Twater	22.0		Twater	22.0		Twater	22.2		Twater	22.2				
RelHum	39.2		RelHum	32.4		RelHum	32.4		RelHum	37.0		RelHum	37.0				
QNH	1012		QNH	1020		QNH	1020		QNH	1021		QNH	1021				
date	20/05/05		date	24/05/05		date	24/05/05		date	25/05/05		date	25/05/05				
time	15:00		time	05:18		time	05:18		time	05:17		time	05:17				

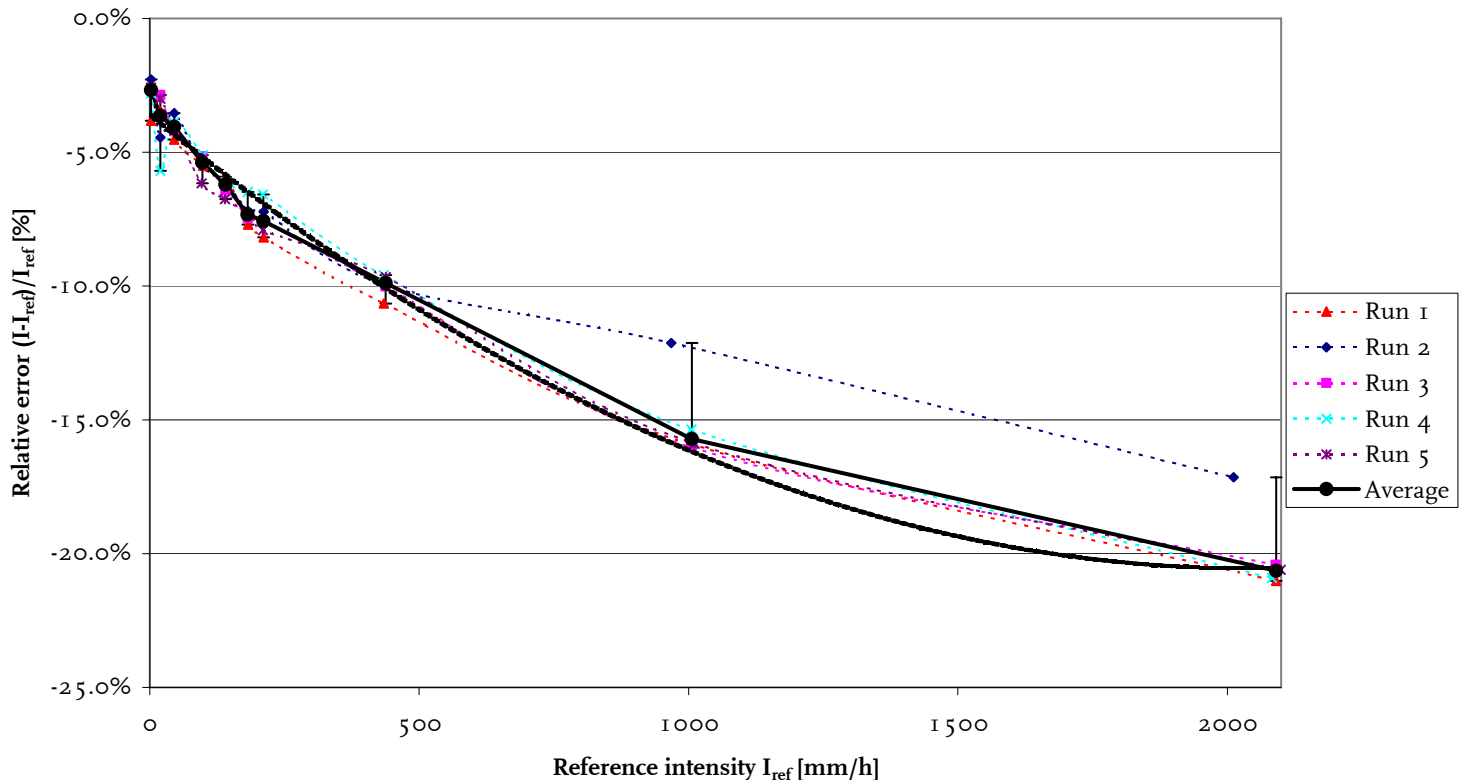

## Appendix 11: SIAP UM7525

Overview of the sensor results derived from tips versus the reference and between the 2 instruments. The coefficients of the polynomial fit and the power law fit are reported and the standard error after correction.

Parameter description	Sensor		
	24268	24276	Combined
Average within WMO range (mm/h)	2-20	2	-
Standard error sensor 1 versus 2	-	-	2.54%
R <sup>2</sup> measured versus reference	0.9991	0.9982	0.9974
Standard error measured versus reference	9.43%	11.82%	10.69%
Polynomial fit to error a	6.32E-07	3.69E-07	4.95E-07
Error in a	2.23E-07	1.72E-07	3.49E-07
Polynomial fit to error b	-0.0005	-0.0006	-0.0005
Error in b	0.0001	0.0001	0.0001
Polynomial fit to error c	-0.029	-0.037	-0.033
Error in c	0.005	0.004	0.007
Polynomial fit to error R <sup>2</sup>	0.9763	0.9919	0.9038
Standard error after correction	0.60%	0.45%	1.50%
Power law fit a	1.012	1.020	1.016
Error in a	0.017	0.029	0.019
Power law fit b	0.969	0.969	0.973
Error in b	0.004	0.006	0.004
Power law fit R <sup>2</sup>	0.9991	0.9991	0.9980
Standard error measured versus power law	1.49%	2.52%	2.71%

Summary of the average and standard deviation of the reference intensities and the time interval between consecutive tips for all 5 tests.

Reference intensity [mm/h]		24268 tip interval [s]		Reference intensity [mm/h]		24276 tip interval [s]	
Average	Std. Dev.	Average	Std. Dev.	Average	Std. Dev.	Average	Std. Dev.
1.99	0.31	375.33	19.38	2.01	0.31	373.72	14.92
21.29	0.50	35.42	3.16	21.44	0.45	35.45	2.38
55.19	25.45*	14.15	1.93	54.32	0.75	14.23	1.94
95.45	0.94	8.22	2.39	95.48	0.93	8.20	2.53
130.69	1.82	6.10	2.07	130.58	2.06	6.25	2.17
168.95	1.50	4.87	0.55	169.52	2.46	4.87	0.55
201.77	1.87	4.39	1.08	201.21	3.03	4.43	1.05
230.79	2.19	3.95	1.23	230.33	3.16	4.09	1.20
267.78	2.36	3.40	1.20	266.89	3.54	3.62	1.25
317.12	3.14	2.77	0.78	317.03	4.11	3.01	1.01

\* During run 2 the reference intensity varied and was on average higher.

1			2			3			4			5			Tips	
UM7525			UM7525			UM7525			UM7525			UM7525				
run #1	run #2	run #3	run #4	run #5												
Ser.nr 24268	Ser.nr 24268	Ser.nr 24268	Ser.nr 24268	Ser.nr 24268												
Tamb 24.7	Tamb 21.1	Tamb 22.4	Tamb 21.4	Tamb 22.8												
Twater 22.1	Twater 18.0	Twater 19.5	Twater 18.3	Twater 20.0												
RelHum 47.5	RelHum 33.1	RelHum 32.1	RelHum 31.4	RelHum 31.1												
QNH 1010	QNH 1010	QNH 1012	QNH 1016	QNH 1017												
date 02/05/05	date 09/05/05	date 09/05/05	date 10/05/05	date 10/05/05												
time 10:58	time 06:44	time 10:49	time 06:41	time 10:43												
@precip.	measured	@precip.	measured	@precip.	measured	@precip.	measured	@precip.	measured	@precip.	measured	@precip.	measured	@precip.	result	
mm/h	deviation	mm/h	deviation	mm/h	deviation	mm/h	deviation	mm/h	deviation	mm/h	deviation	mm/h	deviation	mm/h	deviation	
2	2.0	0.3%	1.9	-0.3%	2.0	-4.0%	2.0	-2.8%	2.0	-6.5%	2.0	-2.3%	2.0	-2.3%		
20	21.3	-1.9%	21.1	-1.1%	21.3	-5.5%	21.2	-5.2%	21.5	-9.0%	21.3	-4.2%	21.3	-4.2%		
50	53.8	-4.0%	54.5	-3.4%	54.3	-5.8%	54.5	-8.2%	54.6	-10.2%	54.2	-6.0%	54.2	-6.0%		
90	94.8	-5.9%	95.5	-6.0%	95.3	-7.9%	95.6	-9.4%	96.2	-11.3%	95.5	-7.8%	95.5	-7.8%		
130	130.9	-7.5%	130.2	-8.1%	131.0	-9.3%	131.5	-10.3%	129.6	-12.4%	130.9	-9.2%	130.9	-9.2%		
170	169.0	-8.9%	167.7	-9.1%	170.0	-9.5%	169.7	-12.0%	168.3	-12.6%	169.1	-10.2%	169.1	-10.2%		
200	201.4	-9.2%	200.2	-10.2%	202.4	-10.0%	203.0	-12.2%	201.8	-13.5%	201.9	-10.8%	201.9	-10.8%		
229	230.0	-10.2%	229.0	-10.5%	231.9	-10.6%	232.6	-12.2%	230.8	-13.4%	231.1	-11.1%	231.1	-11.1%		
262	266.9	-11.2%	265.7	-10.5%	269.0	-11.6%	269.8	-12.5%	267.4	-13.4%	268.6	-11.8%	268.6	-11.8%		
300	319.4	-15.3%	313.5	-12.7%	317.4	-13.3%	319.7	-14.8%	316.0	-14.4%	317.7	-14.2%	317.7	-14.2%		
Tamb 24.9	Tamb 22.4	Tamb 22.8	Tamb 22.7	Tamb 23.1												
Twater 23.0	Twater 19.5	Twater 20.0	Twater 20.0	Twater 20.5												
RelHum 47.8	RelHum 32.3	RelHum 30.4	RelHum 31.2	RelHum 30.4												
QNH 1012	QNH 1012	QNH 1014	QNH 1017	QNH 1019												
date 02/05/05	date 09/05/05	date 09/05/05	date 10/05/05	date 10/05/05												
time 14:50	time 10:46	time 14:40	time 10:38	time 14:43												

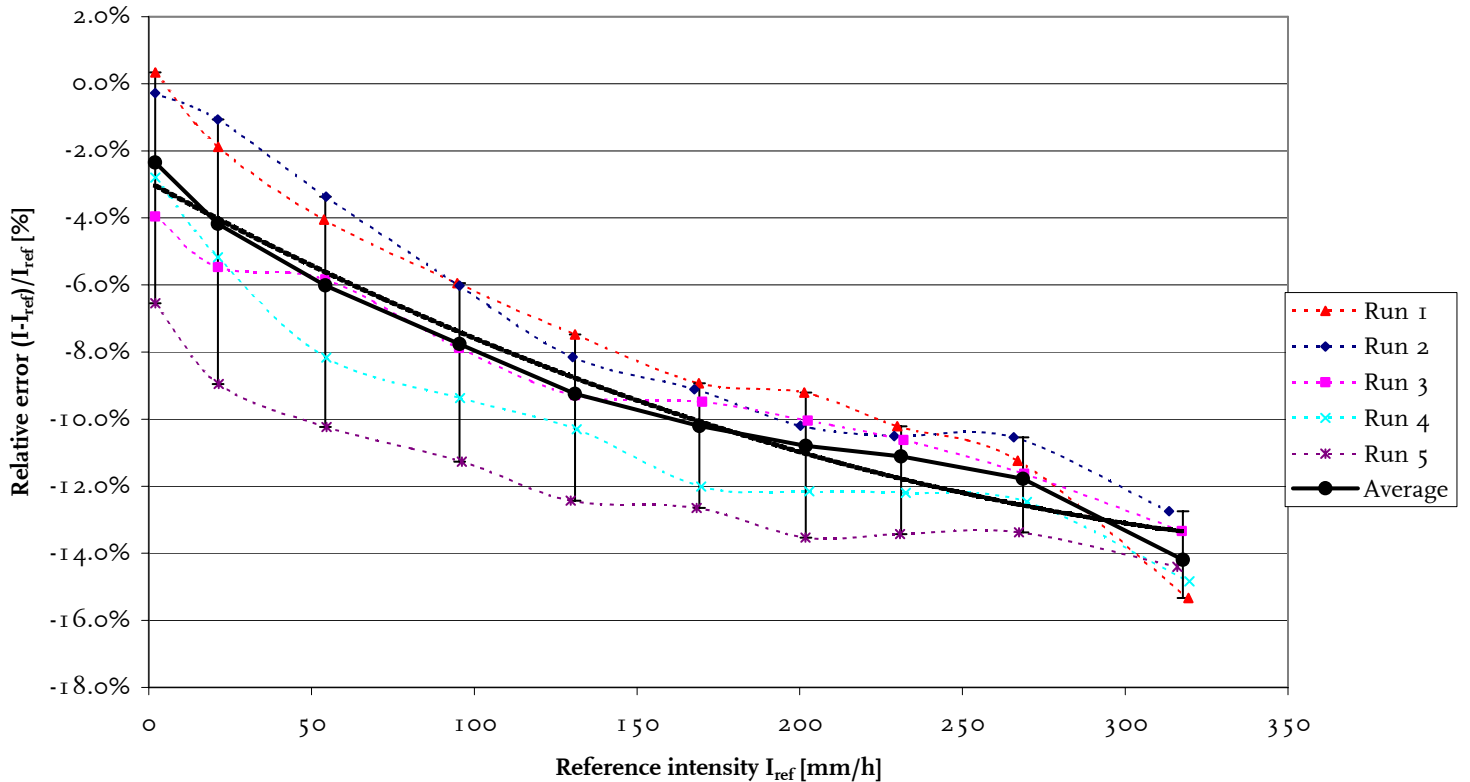

1			2			3			4			5			Tips	
UM7525			UM7525			UM7525			UM7525			UM7525				
run #1	run #2	run #3	run #4	run #5												
Ser.nr 24276	Ser.nr 24276	Ser.nr 24276	Ser.nr 24276	Ser.nr 24276												
Tamb 23.0	Tamb 23.7	Tamb 23.3	Tamb 23.9	Tamb 23.7												
Twater 18.0	Twater 21.0	Twater 19.0	Twater 21.0	Twater 21.0												
RelHum 33.8	RelHum 33.4	RelHum 40.9	RelHum 38.6	RelHum 45.8												
QNH 1020	QNH 1020	QNH 1017	QNH 1019	QNH 1009												
date 28/04/05	date 28/04/05	date 29/04/05	date 29/04/05	date 02/05/05												
time 07:14	time 11:17	time 06:45	time 10:34	time 06:35												
@precip. mm/h	measured deviation	@precip. mm/h	measured deviation	@precip. mm/h	measured deviation	@precip. mm/h	measured deviation	@precip. mm/h	measured deviation	@precip. mm/h	measured deviation	@precip. mm/h	measured deviation	@precip. mm/h	result deviation	
2 2.0 0.0%	0	2.0 -4.9%	I	2.0 -4.6%	I	2.0 -6.2%	O	2.0 -0.2%	I	2.0 -3.2%						
20 21.3 -1.9%	O	21.6 -7.4%	I	21.4 -7.1%	I	21.5 -7.9%	O	21.3 -1.9%	I	21.5 -5.5%						
50 54.3 -4.0%	O	54.7 -8.9%	O	54.3 -8.6%	I	54.2 -8.5%	I	54.2 -4.4%	I	54.2 -7.2%						
90 95.1 -5.8%	I	96.3 -9.7%	O	95.2 -9.4%	I	95.3 -9.6%	I	95.4 -5.0%	O	95.2 -8.3%						
130 128.7 -9.5%	I	129.5 -10.0%	I	130.8 -10.3%	I	130.5 -10.8%	O	133.4 -6.5%	O	129.7 -9.9%						
170 167.5 -11.3%	I	168.3 -13.5%	O	169.3 -12.2%	I	169.1 -12.1%	I	173.4 -8.6%	O	168.6 -11.9%						
200 198.1 -11.9%	O	200.1 -17.4%	O	201.0 -14.3%	I	201.0 -13.9%	I	205.7 -13.2%	I	202.6 -13.8%						
229 227.2 -13.8%	O	228.8 -18.3%	O	230.2 -15.3%	I	230.4 -15.3%	I	235.2 -15.0%	I	231.9 -15.2%						
262 263.3 -15.2%	O	265.4 -18.1%	O	266.9 -16.0%	I	267.6 -16.2%	I	272.2 -16.3%	I	268.9 -16.2%						
300 312.4 -17.6%	I	314.9 -22.1%	O	315.7 -17.2%	O	319.8 -17.6%	I	322.2 -17.9%	I	318.1 -17.7%						
Tamb 23.6	Tamb 23.9	Tamb 23.9	Tamb 24.3	Tamb 24.4												
Twater 20.6	Twater 21.5	Twater 21.0	Twater 22.0	Twater 22.0												
RelHum 33.7	RelHum 32.3	RelHum 38.8	RelHum 38.7	RelHum 47.0												
QNH 1020	QNH 1018	QNH 1019	QNH 1019	QNH 1011												
date 28/04/05	date 28/04/05	date 29/04/05	date 29/04/05	date 02/05/05												
time 11:08	time 15:11	time 10:31	time 14:31	time 10:24												

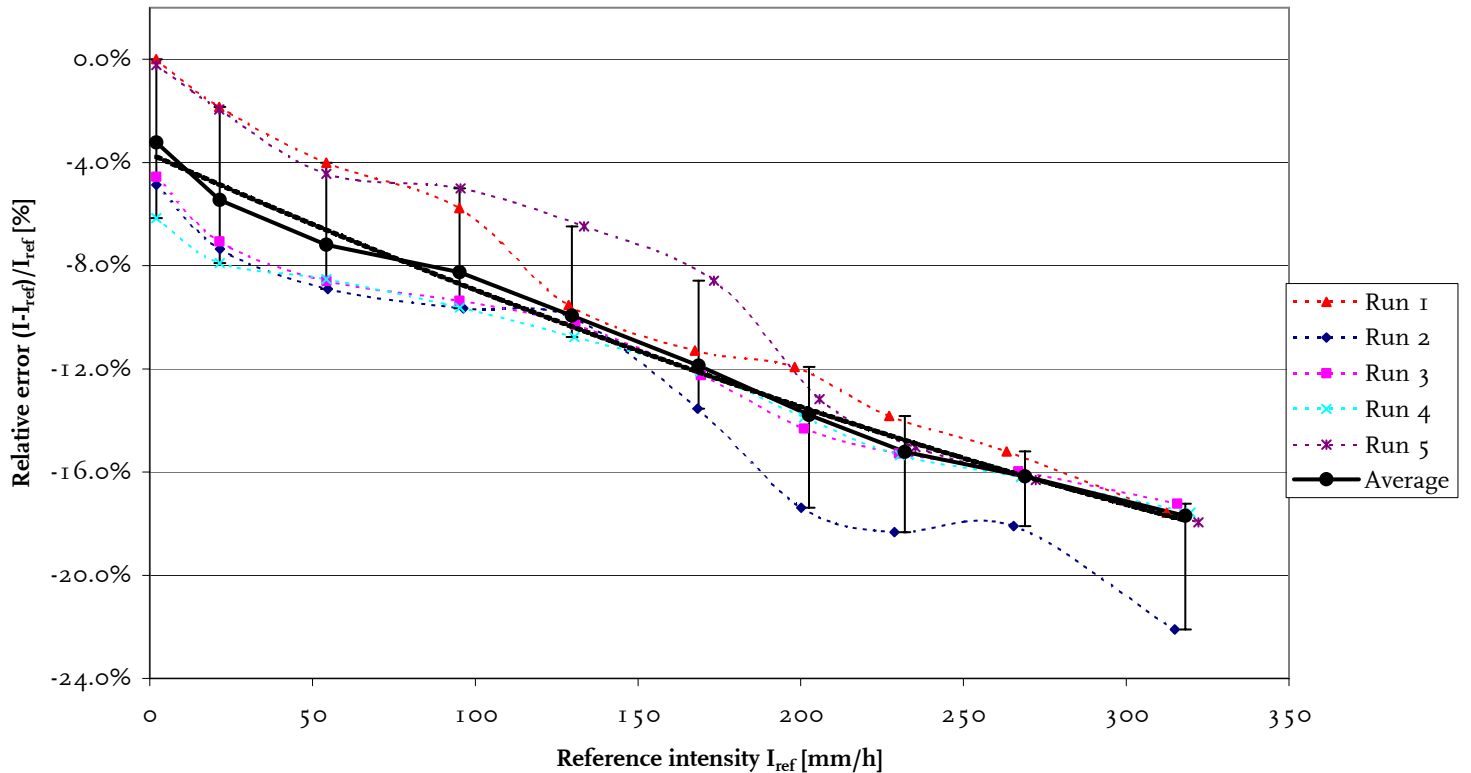

## Appendix 12: CAE PMB2

Overview of the sensor results derived from the reported corrected intensity derived from the tips versus the reference and between the 2 instruments. The coefficients of the polynomial fit and the power law fit are reported and the standard error after correction.

Parameter description	Sensor		
	12903	14897	Combined
Average within WMO range (mm/h)	2-300	2-300	-
Standard error sensor 1 versus 2	-	-	1.14%
R <sup>2</sup> measured versus reference	0.9998	0.9997	0.9996
Standard error measured versus reference	1.58%	2.30%	1.97%
Polynomial fit to error a	3.59E-07	4.42E-07	4.02E-07
Error in a	1.68E-07	1.52E-07	1.85E-07
Polynomial fit to error b	0.0000	0.0000	0.0000
Error in b	0.0001	0.0000	0.0001
Polynomial fit to error c	-0.010	0.002	-0.004
Error in c	0.003	0.003	0.004
Polynomial fit to error R <sup>2</sup>	0.9289	0.9458	0.8230
Standard error after correction	0.39%	0.35%	0.67%
Power law fit a	0.979	0.989	0.984
Error in a	0.013	0.013	0.009
Power law fit b	1.006	1.006	1.006
Error in b	0.003	0.003	0.002
Power law fit R <sup>2</sup>	0.9998	0.9998	0.9997
Standard error measured versus power law	1.14%	1.16%	1.40%

Summary of the average and standard deviation of the reference intensities and the corrected time interval between consecutive tips for all 5 tests.

Reference intensity [mm/h]		12903 tip interval [s]		Reference intensity [mm/h]		14897 tip interval [s]	
Average	Std. Dev.	Average	Std. Dev.	Average	Std. Dev.	Average	Std. Dev.
1.96	0.35	370.90	8.54	1.99	0.32	364.74	7.47
21.32	0.46	34.28	1.56	21.21	0.82	33.87	2.12
54.07	0.92	13.44	2.10	54.08	0.91	13.30	2.17
94.68	2.97*	7.65	2.43	94.74	0.94	7.59	2.44
128.73	1.37	5.63	2.05	129.67	1.61	5.51	1.97
167.34	1.54	4.40	0.61	168.21	1.40	4.35	0.68
197.70	2.71	3.97	1.06	199.00	1.89	3.91	1.09
226.97	2.91	3.55	1.23	228.44	1.80	3.50	1.24
265.26	5.06	3.01	1.22	264.93	2.04	2.98	1.21
310.32	6.11	2.40	0.87	312.95	3.17	2.33	0.78

\* During run 1 the reference intensity varied.

Overview of the sensor results derived from the raw tips versus the reference and between the 2 instruments. The coefficients of the polynomial fit and the power law fit are reported and the standard error after correction.

Parameter description	Sensor		
	12903	14897	Combined
Average within WMO range (mm/h)	2-50	2-50	-
Standard error sensor 1 versus 2	-	-	0.95%
R <sup>2</sup> measured versus reference	0.9988	0.9988	0.9987
Standard error measured versus reference	8.68%	7.99%	8.34%
Polynomial fit to error a	5.17E-07	5.59E-07	5.45E-07
Error in a	1.64E-07	1.44E-07	1.64E-07
Polynomial fit to error b	-0.0006	-0.0006	-0.0006
Error in b	0.0001	0.0000	0.0001
Polynomial fit to error c	-0.010	0.002	-0.004
Error in c	0.003	0.003	0.003
Polynomial fit to error R <sup>2</sup>	0.9920	0.9938	0.9806
Standard error after correction	0.39%	0.35%	0.62%
Power law fit a	1.040	1.052	1.046
Error in a	0.023	0.024	0.016
Power law fit b	0.972	0.972	0.973
Error in b	0.005	0.005	0.003
Power law fit R <sup>2</sup>	0.9994	0.9994	0.9993
Standard error measured versus power law	1.94%	2.02%	2.11%

1			2			3			4			5			Corrected	
PMB <sub>2</sub> #1			PMB <sub>2</sub> #2			PMB <sub>2</sub> #3			PMB <sub>2</sub> #4			PMB <sub>2</sub> #5				
run	#1		run	#2		run	#3		run	#4		run	#5			
Ser.nr	12903		Ser.nr	12903		Ser.nr	12903		Ser.nr	12903		Ser.nr	12903			
Tamb	22.6		Tamb	22.7		Tamb	22.0		Tamb	21.8		Tamb	23.0			
Twater	19.2		Twater	20.0		Twater	18.1		Twater	18.9		Twater	20.2			
RelHum	32.6		RelHum	30.5		RelHum	40.7		RelHum	38.3		RelHum	39.9			
QNH	1023		QNH	1021		QNH	1003		QNH	999		QNH	998			
date	12/04/05		date	12/04/05		date	14/04/05		date	18/04/05		date	18/04/05			
time	09:23		time	13:18		time	07:03		time	06:41		time	10:41			
@precip.	measured		@precip.	measured		@precip.	measured		@precip.	measured		@precip.	measured		@precip.	result
mm/h	deviation		mm/h	deviation		mm/h	deviation		mm/h	deviation		mm/h	deviation		mm/h	deviation
2	1.9	-0.7% I	1.9	-1.0% O	1.9	2.0% O	2.0	0.7% I	2.0	-0.7% I	2.0	-0.3% I				
20	21.2	-1.2% O	21.7	-1.6% I	21.1	-1.3% I	21.3	-1.6% O	21.3	-1.4% I	21.3	-1.4% I				
50	53.9	0.3% O	54.1	-1.0% I	54.1	-0.3% I	54.0	-1.4% O	54.1	-1.1% I	54.1	-0.8% I				
90	94.1	0.6% O	94.8	-0.8% O	94.6	-0.6% I	94.6	-0.6% I	95.1	-0.8% O	94.8	-0.7% I				
130	128.4	-1.5% O	129.5	-0.3% I	128.7	-0.3% I	128.5	-0.8% I	128.8	-0.3% O	128.9	-0.5% O				
170	168.8	0.3% O	167.0	0.8% I	166.6	0.4% I	166.7	2.1% O	167.6	1.5% I	167.1	0.9% O				
200	202.2	0.5% O	196.2	1.3% I	196.8	1.4% I	196.8	1.4% I	196.7	1.9% O	196.6	1.4% O				
229	231.6	1.9% I	225.1	1.7% O	225.7	1.8% I	225.9	1.7% I	226.8	2.6% O	227.7	1.8% O				
262	274.2	2.1% I	261.2	2.0% O	262.4	2.3% I	263.1	4.5% O	265.7	2.6% I	267.4	2.3% O				
300	321.7	3.1% I	305.9	3.4% I	308.6	3.2% I	308.5	4.6% O	306.8	3.1% O	312.1	3.2% O				
Tamb	22.5		Tamb	23.1		Tamb	23.3		Tamb	23.1		Tamb	23.2			
Twater	20.0		Twater	20.8		Twater	21.0		Twater	21.0		Twater	21.0			
RelHum	31.3		RelHum	36.4		RelHum	37.0		RelHum	37.7		RelHum	40.0			
QNH	1021		QNH	1004		QNH	1005		QNH	1005		QNH	999			
date	12/04/05		date	19/04/05		date	19/04/05		date	19/04/05		date	18/04/05			
time	13:09		time	09:09		time	15:03		time	13:09		time	14:33			

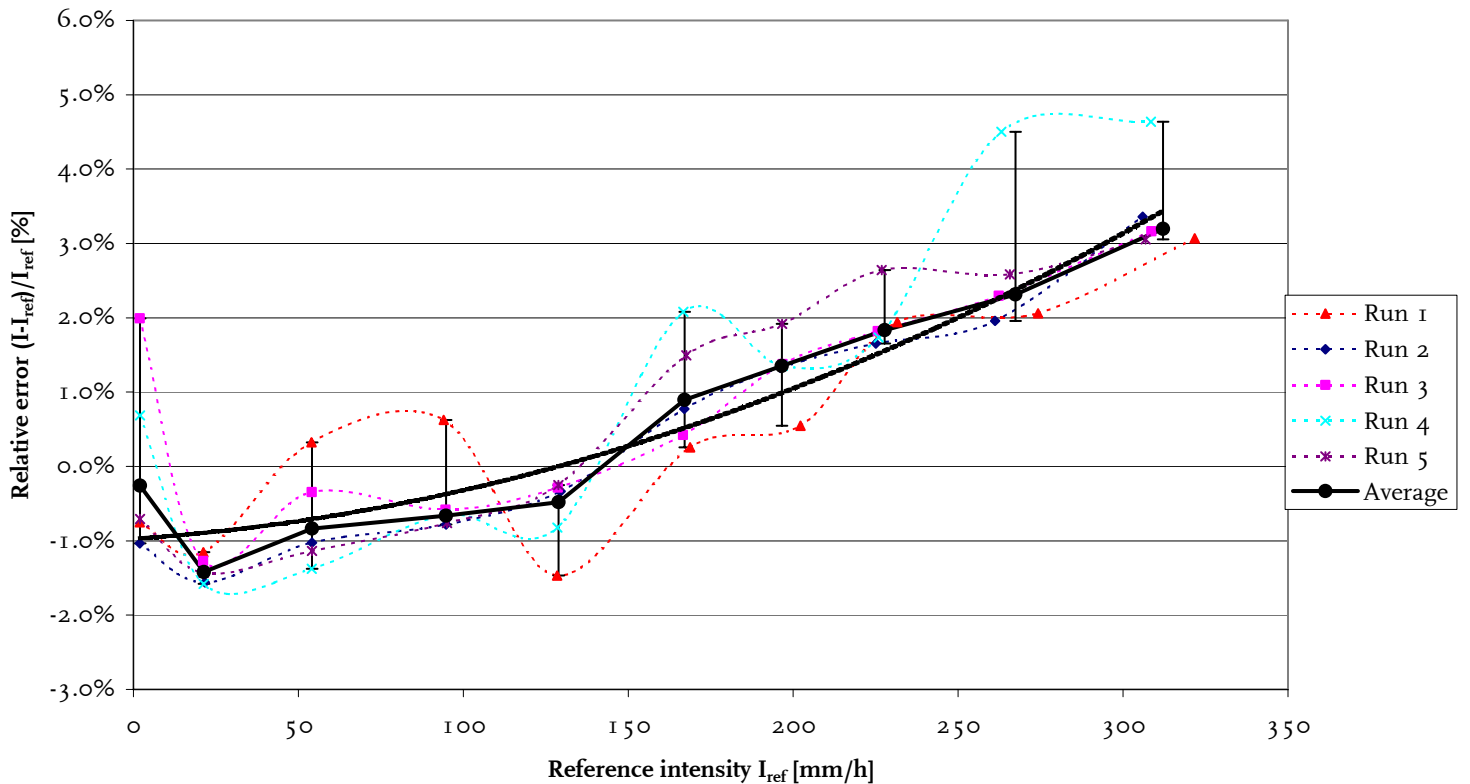

1			2			3			4			5			Corrected	
PMB <sub>2</sub> <sup>1</sup>			PMB <sub>2</sub> <sup>2</sup>			PMB <sub>2</sub> <sup>3</sup>			PMB <sub>2</sub> <sup>4</sup>			PMB <sub>2</sub> <sup>5</sup>				
run #1	run #2	run #3	run #4	run #5												
Ser.nr 14897	Ser.nr 14897	Ser.nr 14897	Ser.nr 14897	Ser.nr 14897												
Tamb 22.9	Tamb 23.2	Tamb 22.8	Tamb 23.0	Tamb 23.6												
Twater 19.8	Twater 20.0	Twater 18.0	Twater 20.8	Twater 21.0												
RelHum 34.0	RelHum 22.2	RelHum 32.7	RelHum 37.6	RelHum 34.6												
QNH 1012	QNH 1021	QNH 1012	QNH 1011	QNH 1014												
date 20/04/05	date 21/04/05	date 26/04/05	date 27/04/05	date 27/04/05												
time 09:39	time 10:05	time 07:39	time 06:38	time 10:46												
@precip. mm/h	measured deviation	@precip. mm/h	measured deviation	@precip. mm/h	measured deviation	@precip. mm/h	measured deviation	@precip. mm/h	measured deviation	@precip. mm/h	measured deviation	@precip. mm/h	measured deviation	@precip. mm/h	result deviation	
2 1.9	1.6%	2.0	-0.7%	1.9	1.0%	2.0	0.8%	2.0	0.1%	2.0	0.1%	2.0	0.6%	2.0	0.6%	
20 21.2	-0.3%	21.3	-0.3%	20.9	1.9%	21.3	0.7%	21.3	-0.4%	21.3	-0.4%	21.3	0.0%	21.3	0.0%	
50 54.2	0.8%	53.9	-0.5%	53.9	0.5%	54.3	0.3%	54.0	-0.2%	54.0	-0.2%	54.1	0.2%	54.1	0.2%	
90 94.6	0.7%	94.5	-0.4%	94.2	0.1%	95.4	0.5%	95.1	0.1%	94.9	0.3%	94.9	0.3%	94.9	0.3%	
130 130.4	0.4%	128.8	0.2%	129.1	0.6%	129.8	0.9%	130.2	0.6%	129.9	0.6%	129.9	0.6%	129.9	0.6%	
170 168.4	2.7%	168.0	1.3%	167.8	2.1%	168.5	3.2%	168.6	2.0%	168.2	2.3%	168.2	2.3%	168.2	2.3%	
200 198.8	2.3%	198.5	2.4%	198.0	2.7%	199.7	2.3%	200.0	2.2%	199.0	2.3%	199.0	2.3%	199.0	2.3%	
229 228.1	2.1%	228.3	2.4%	227.3	2.8%	229.1	3.4%	229.5	2.8%	228.4	2.7%	228.4	2.7%	228.4	2.7%	
262 265.3	3.3%	264.6	3.0%	263.9	3.7%	265.6	3.8%	265.5	3.8%	264.9	3.6%	264.9	3.6%	264.9	3.6%	
300 310.0	4.5%	310.8	4.6%	315.9	4.6%	313.2	5.2%	314.8	4.6%	313.8	4.6%	313.8	4.6%	313.8	4.6%	
Tamb 23.1	Tamb 23.3	Tamb 23.3	Tamb 23.6	Tamb 23.6												
Twater 20.0	Twater 20.8	Twater 20.8	Twater 21.0	Twater 21.5												
RelHum 22.2	RelHum 21.4	RelHum 37.1	RelHum 34.8	RelHum 30.3												
QNH 1021	QNH 1020	QNH 1013	QNH 1014	QNH 1016												
date 21/04/05	date 21/04/05	date 26/04/05	date 27/04/05	date 27/04/05												
time 09:46	time 14:15	time 11:26	time 10:40	time 14:40												

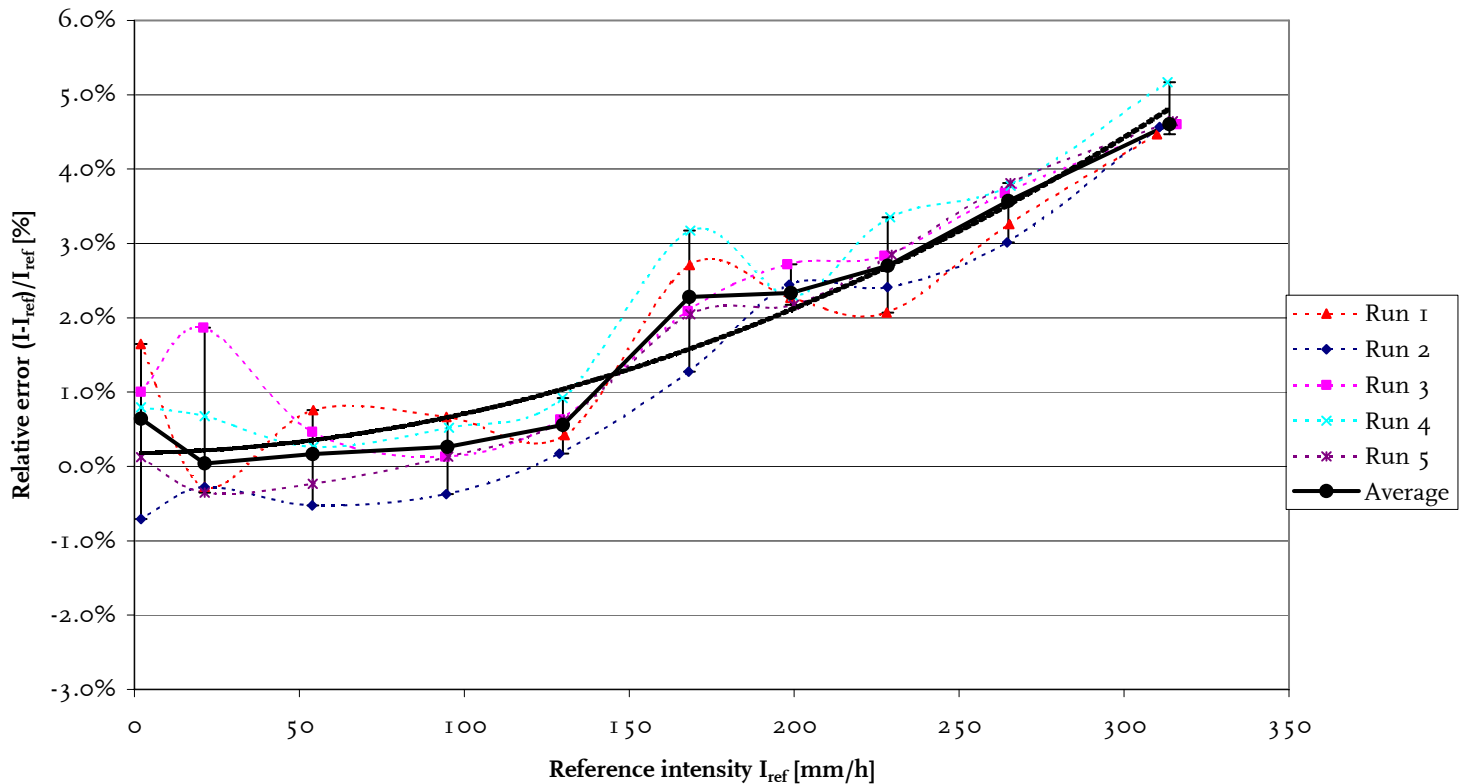

## Appendix 13: ETG R102

Overview of the sensor results derived from the increment in precipitation accumulation versus the reference and between the 2 instruments. The coefficients of the polynomial fit and the power law fit are reported and the standard error after correction.

Parameter description	Sensor		
	1535	1536	Combined
Average within WMO range (mm/h)	2-300	2-300	-
Standard error sensor 1 versus 2	-	-	0.73%
R <sup>2</sup> measured versus reference	0.9997	0.9996	0.9996
Standard error measured versus reference	2.14%	1.95%	2.05%
Polynomial fit to error a	-1.51E-06	-1.22E-06	-1.37E-06
Error in a	4.25E-07	2.65E-07	2.38E-07
Polynomial fit to error b	0.0004	0.0003	0.0004
Error in b	0.0001	0.0001	0.0001
Polynomial fit to error c	-0.033	-0.022	-0.027
Error in c	0.009	0.005	0.005
Polynomial fit to error R <sup>2</sup>	0.6428	0.7909	0.6711
Standard error after correction	1.00%	0.63%	0.88%
Power law fit a	0.961	0.982	0.971
Error in a	0.015	0.015	0.010
Power law fit b	1.001	1.001	1.003
Error in b	0.003	0.003	0.002
Power law fit R <sup>2</sup>	0.9996	0.9996	0.9996
Standard error measured versus power law	1.43%	1.36%	1.48%

Summary of the average and standard deviation of the reference intensities and the corrected time interval between consecutive tips for all 5 tests.

Reference intensity [mm/h]		1535 tip interval [s]		Reference intensity [mm/h]		1536 tip interval [s]	
Average	Std. Dev.	Average	Std. Dev.	Average	Std. Dev.	Average	Std. Dev.
1.84	0.05	410.75	17.36	1.84	0.96	393.92	10.29
20.51	0.32	36.49	12.89	21.20	0.40	35.03	11.77
52.61	0.66	14.10	2.41	53.77	0.78	13.91	2.17
95.39	1.36	7.84	1.64	94.20	1.27	7.94	1.50
125.69	2.66	5.84	0.97	127.66	5.29	5.70	0.79
161.43	2.64	4.53	0.47	163.44	7.29	4.42	0.37
192.70	4.16	3.80	0.29	194.79	7.44	3.74	0.22
222.56	4.13	3.30	0.25	223.54	8.54	3.28	0.21
260.18	7.73	2.84	0.20	260.39	9.78	2.84	0.19
307.69	7.18	2.41	0.12	309.58	9.55	2.41	0.15

\* During run 1 the reference intensity varied.

Overview of the sensor results derived from the reported intensity versus the reference and between the 2 instruments. The coefficients of the polynomial fit and the power law fit are reported and the standard error after correction.

Parameter description	Sensor		
	1535	1536	Combined
Average within WMO range (mm/h)	2-300	2-300	-
Standard error sensor 1 versus 2	-	-	6.09%
R <sup>2</sup> measured versus reference	0.9988	0.9984	0.9984
Standard error measured versus reference	16.20%	12.35%	14.40%
Polynomial fit to error a	-3.21E-06	-6.14E-07	-1.84E-06
Error in a	2.35E-06	5.88E-07	1.26E-06
Polynomial fit to error b	0.0009	-0.0002	0.0003
Error in b	0.0007	0.0002	0.0004
Polynomial fit to error c	-0.179	-0.077	-0.127
Error in c	0.045	0.012	0.025
Polynomial fit to error R <sup>2</sup>	0.2233	0.8598	0.2496
Standard error after correction	6.21%	1.50%	5.12%
Power law fit a	0.773	0.947	0.855
Error in a	0.058	0.036	0.040
Power law fit b	0.984	0.984	1.002
Error in b	0.016	0.008	0.010
Power law fit R <sup>2</sup>	0.9989	0.9989	0.9977
Standard error measured versus power law	6.61%	3.35%	7.31%

Summary of the average and standard deviation of the running 1-minute averaged reference and measured intensities for all 5 tests.

Reference intensity [mm/h]		1535 intensity [mm/h]		Reference intensity [mm/h]		1536 intensity [mm/h]	
Average	Std. Dev.	Average	Std. Dev.	Average	Std. Dev.	Average	Std. Dev.
1.84	0.05	1.33	0.00	1.88	0.04	1.68	0.00
20.51	0.32	18.92	0.02	21.20	0.40	19.89	0.02
52.07	3.48	47.56	0.07	53.22	3.59	49.61	0.07
94.36	6.42	83.96	0.12	93.20	6.29	84.92	0.06
125.67	2.84	110.32	0.12	127.61	5.38	115.02	0.20
159.86	10.05	137.83	0.08	161.83	12.28	143.87	0.20
192.04	8.48	162.27	0.15	194.53	7.89	169.03	0.14
220.65	15.09	185.19	0.11	223.34	8.86	189.08	0.24
258.95	13.67	215.06	0.16	260.02	10.70	218.96	0.16
304.11	25.65	249.16	0.27	309.37	9.96	256.91	0.15

1			2			3			4			5			Tips	
ETG R102			ETG R102			ETG R102			ETG R102			ETG R102				
run	#1		run	#2		run	#3		run	#4		run	#5			
Ser.nr	1535		Ser.nr	1535		Ser.nr	1535		Ser.nr	1535		Ser.nr	1535			
Tamb	23.2		Tamb	22.3		Tamb	22.4		Tamb	22.3		Tamb	21.4			
Twater	15.5		Twater	19.0		Twater	22.0		Twater	11.0		Twater	18.0			
RelHum	20.5		RelHum	21.5		RelHum	23.3		RelHum	23.1		RelHum	16.2			
QNH	1005		QNH	1000		QNH	1002		QNH	1012		QNH	1015			
date	01/03/05		date	02/03/05		date	02/03/05		date	03/03/05		date	04/03/05			
time	12:44		time	08:54		time	15:08		time	10:25		time	07:22			
@precip.	measured		@precip.	measured		@precip.	measured		@precip.	measured		@precip.	measured		@precip.	result
mm/h	deviation		mm/h	deviation		mm/h	deviation		mm/h	deviation		mm/h	deviation		mm/h	deviation
2	1.9	-5.3% I	1.8	-3.8% O	1.8	-4.5% I	1.8	-4.7% I	1.9	-5.5% O	1.8	-4.8%		1.8	-4.8%	
20	19.9	-0.3% I	20.6	-3.1% I	20.7	-3.5% O	20.5	-2.6% I	20.7	-0.2% O	20.4	-2.0%		20.4	-2.0%	
50	51.5	1.0% O	52.9	-0.2% I	52.9	-0.1% I	52.4	-0.8% O	53.5	0.4% I	53.1	0.0%		53.1	0.0%	
90	94.2	2.0% O	96.9	0.7% I	96.7	0.1% I	95.6	0.4% I	93.5	-0.6% O	96.4	0.4%		96.4	0.4%	
130	129.9	1.6% O	126.9	0.3% I	125.6	0.0% O	123.8	1.6% I	122.6	1.0% I	124.4	1.0%		124.4	1.0%	
170	165.6	0.5% O	162.8	-1.4% O	161.1	-0.5% I	159.8	0.3% I	158.1	-0.8% I	159.6	-0.4%		159.6	-0.4%	
200	192.9	-0.1% O	191.4	-1.4% I	190.3	-1.2% I	188.5	-1.5% I	200.4	-1.8% O	190.1	-1.4%		190.1	-1.4%	
229	224.2	-0.2% O	220.1	-1.1% I	220.1	-1.5% I	218.5	-1.9% I	229.8	-2.5% O	219.6	-1.5%		219.6	-1.5%	
262	260.3	-0.3% O	256.9	-1.8% I	255.4	-2.3% I	253.7	-2.4% I	274.9	-3.1% O	255.3	-2.2%		255.3	-2.2%	
300	307.9	-1.4% O	305.9	-2.7% I	303.0	-3.9% O	300.5	-2.0% I	321.2	-3.8% I	309.2	-2.9%		309.2	-2.9%	
Tamb	22.6		Tamb	22.5		Tamb	22.2		Tamb	22.7		Tamb	22.5			
Twater	18.5		Twater	22.0		Twater	18.5		Twater	18.5		Twater	19.5			
RelHum	21.2		RelHum	23.5		RelHum	22.7		RelHum	21.9		RelHum	16.6			
QNH	1004		QNH	1002		QNH	1012		QNH	1014		QNH	1010			
date	01/03/05		date	02/03/05		date	03/03/05		date	03/03/05		date	04/03/05			
time	17:07		time	14:54		time	10:00		time	14:42		time	12:21			

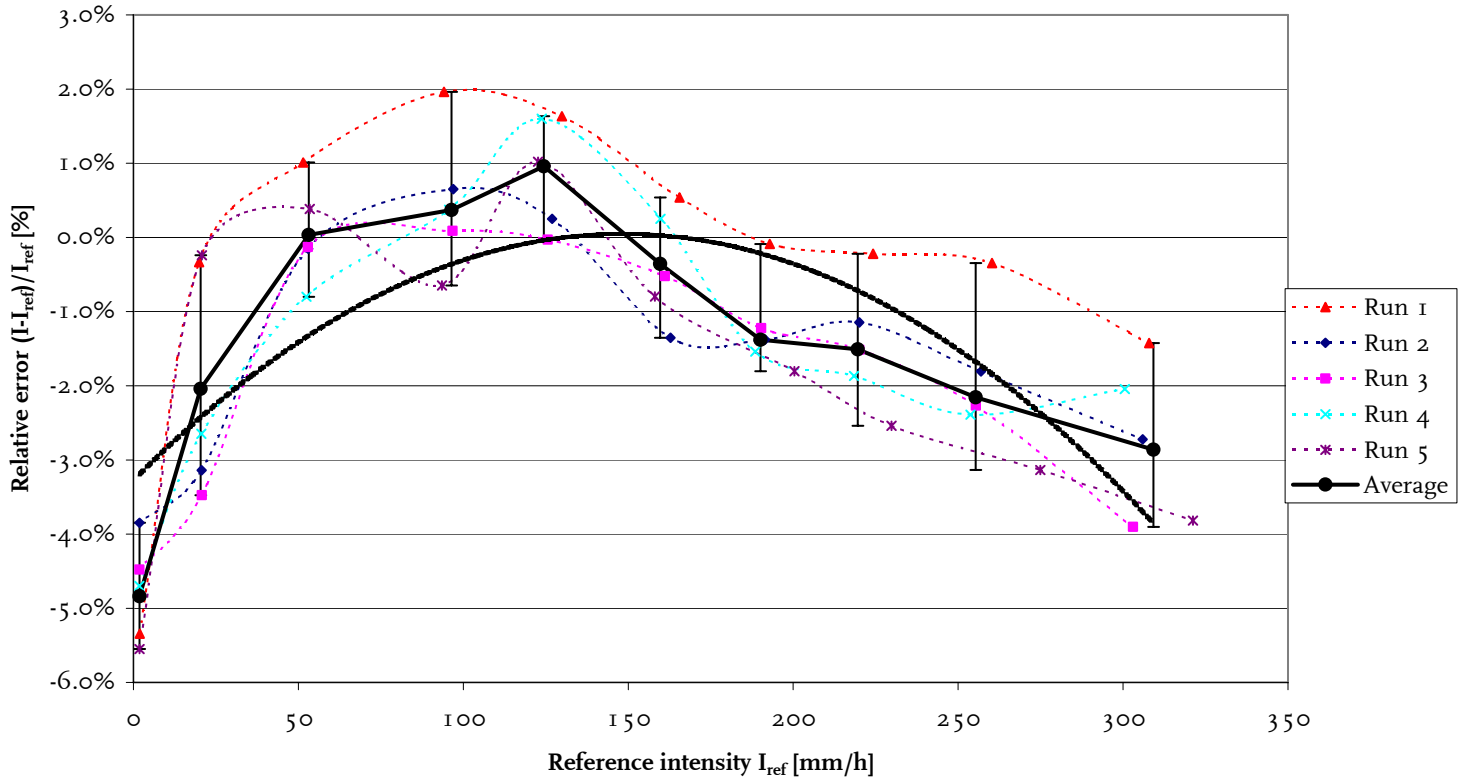

1			2			3			4			5			Tips	
ETG R102			ETG R102			ETG R102			ETG R102			ETG R102				
run #1			run #2			run #3			run #4			run #5				
Ser.nr	1536		Ser.nr	1536		Ser.nr	1536		Ser.nr	1536		Ser.nr	1536			
Tamb	22.6		Tamb	22.0		Tamb	22.3		Tamb	22.9		Tamb	22.8			
Twater	14.8		Twater	17.2		Twater	19.0		Twater	19.5		Twater	19.5			
RelHum	27.7		RelHum	28.8		RelHum	25.4		RelHum	28.3		RelHum	35.0			
QNH	1006		QNH	1012		QNH	1013		QNH	1018		QNH	1019			
date	11/03/05		date	14/03/05		date	14/03/05		date	15/03/05		date	16/03/05			
time	12:21		time	09:53		time	14:23		time	14:07		time	11:37			
@precip.	measured		@precip.	measured		@precip.	measured		@precip.	measured		@precip.	measured		@precip.	result
mm/h	deviation		mm/h	deviation		mm/h	deviation		mm/h	deviation		mm/h	deviation		mm/h	deviation
2	1.9	-2.9% I	1.9	-2.8% I		1.9	-3.5% O		1.9	-3.0% I		1.9	-1.9% O		1.9	-2.9%
20	20.6	0.5% I	21.6	-3.9% O		21.4	-3.1% I		21.1	-2.0% I		21.3	1.1% O		21.0	-1.6%
50	52.4	0.6% I	54.6	-0.7% I		54.0	2.2% O		53.9	-0.9% O		54.0	-0.7% I		53.6	-0.3%
90	91.9	0.2% I	95.6	-0.4% O		94.5	0.8% O		94.7	-0.3% I		94.5	0.0% I		93.7	0.0%
130	122.1	0.9% I	136.1	-0.1% I		127.3	1.3% I		129.2	-0.9% O		123.8	2.1% O		128.5	0.7%
170	158.6	0.5% I	176.0	-1.0% I		162.7	-0.2% I		165.4	-1.7% O		154.5	5.1% O		165.8	-0.2%
200	187.8	-1.2% I	206.8	-1.8% I		194.1	-1.5% I		197.5	-2.4% O		187.9	2.2% O		196.2	-1.5%
229	216.6	-2.1% I	236.7	-2.0% I		222.8	-1.7% I		227.3	-3.3% O		214.7	1.5% O		225.4	-1.9%
262	253.4	-3.4% I	275.9	-3.2% I		258.3	-2.4% I		264.7	-3.9% O		250.0	1.5% O		262.5	-3.0%
300	305.2	-4.1% I	323.1	-3.2% I		307.9	-3.1% I		315.0	-4.5% O		297.0	0.5% O		312.1	-3.4%
Tamb	22.0		Tamb	22.4		Tamb	22.4		Tamb	22.9		Tamb	23.4			
Twater	17.0		Twater	19.0		Twater	18.5		Twater	19.8		Twater	20.9			
RelHum	28.3		RelHum	26.7		RelHum	26.4		RelHum	34.8		RelHum	38.8			
QNH	1012		QNH	1013		QNH	1018		QNH	1019		QNH	1018			
date	14/03/05		date	14/03/05		date	15/03/05		date	16/03/05		date	16/03/05			
time	09:37		time	14:07		time	12:24		time	11:04		time	15:33			

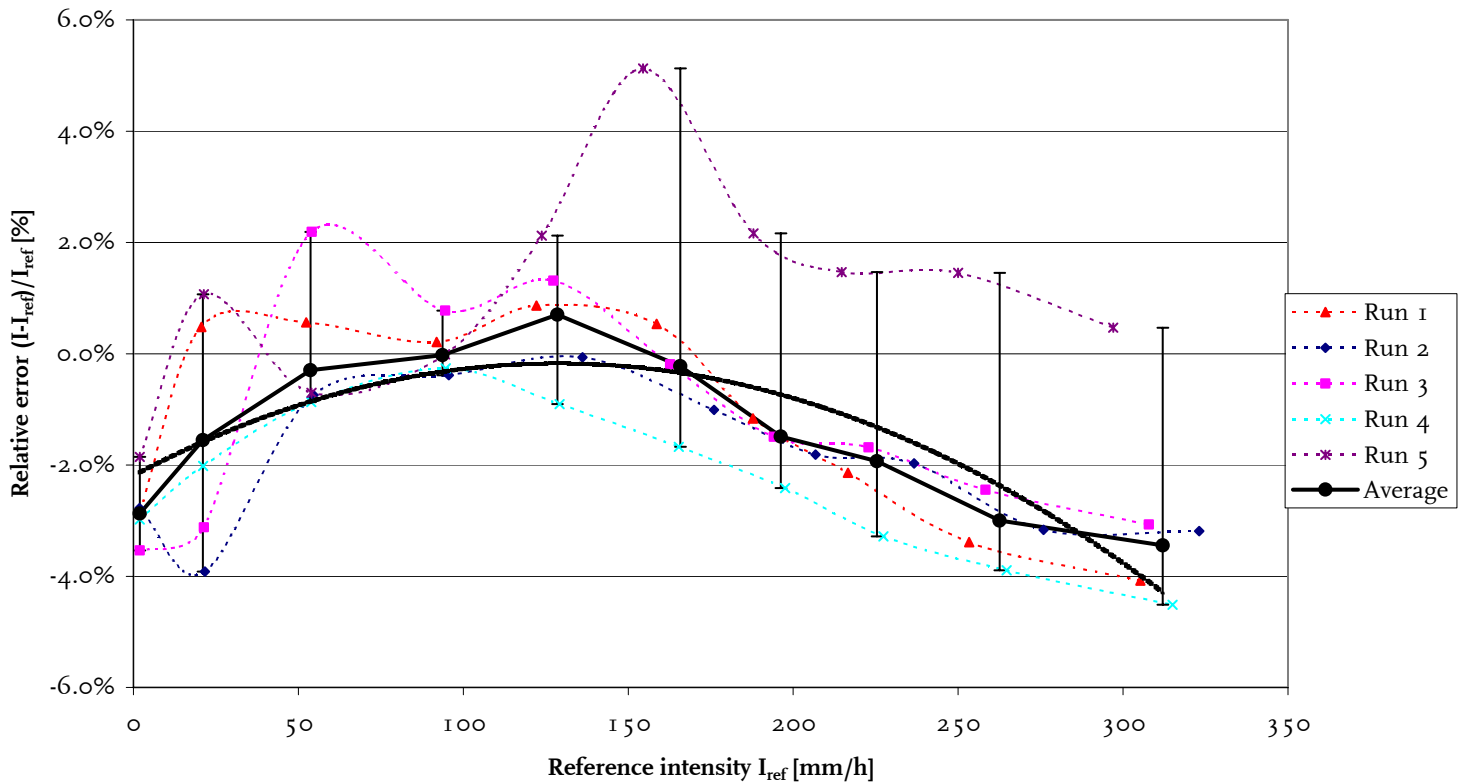

## Appendix 14: Yokogawa Denshi Kiki Co. WMB01

Overview of the sensor results derived from the reported intensity versus the reference and between the 2 instruments. The coefficients of the polynomial fit and the power law fit are reported and the standard error after correction.

Parameter description	Sensor		
	299	456	Combined
Average within WMO range (mm/h)	2-200	2-200	-
Standard error sensor 1 versus 2	-	-	0.81%
R <sup>2</sup> measured versus reference	1.0000	1.0000	0.9999
Standard error measured versus reference	1.39%	1.21%	1.30%
Polynomial fit to error a	-1.99E-06	-9.62E-07	-1.48E-06
Error in a	1.09E-06	8.72E-07	6.67E-07
Polynomial fit to error b	0.0005	0.0002	0.0003
Error in b	0.0002	0.0002	0.0001
Polynomial fit to error c	-0.023	-0.012	-0.017
Error in c	0.009	0.007	0.005
Polynomial fit to error R <sup>2</sup>	0.5296	0.2759	0.3197
Standard error after correction	0.84%	0.68%	0.86%
Power law fit a	0.969	0.986	0.977
Error in a	0.009	0.009	0.007
Power law fit b	1.001	1.001	1.004
Error in b	0.002	0.002	0.002
Power law fit R <sup>2</sup>	1.0000	1.0000	0.9999
Standard error measured versus power law	0.77%	0.77%	0.95%

Summary of the average and standard deviation of the running 1-minute averaged reference and measured intensities for all 5 tests.

Reference intensity [mm/h]		299 intensity [mm/h]		Reference intensity [mm/h]		456 intensity [mm/h]	
Average	Std. Dev.	Average	Std. Dev.	Average	Std. Dev.	Average	Std. Dev.
2.04	0.09	1.97	0.07	1.94	0.12	1.90	0.09
19.92	0.20	19.91	0.75	20.59	0.35	20.67	0.57
43.82	0.49	43.87	1.58	46.77	0.83	46.71	1.18
90.53	2.09	90.28	3.37	90.49	1.08	89.90	2.04
128.90	2.27	128.63	4.57	128.84	1.74	127.51	2.95
172.22	3.65	171.62	6.00	172.06	2.24	170.12	3.63
204.76	3.99	203.26	6.52	204.86	2.50	202.12	4.20

1			2			3			4			5				
WMB <sub>01</sub>			WMB <sub>01</sub>			WMB <sub>01</sub>			WMB <sub>01</sub>			WMB <sub>01</sub>				
run	#1		run	#2		run	#3		run	#4		run	#5			
Ser.nr	299		Ser.nr	299		Ser.nr	299		Ser.nr	299		Ser.nr	299			
Tamb	23.6		Tamb	21.9		Tamb	22.0		Tamb	22.5		Tamb	22.6			
Twater	20.2		Twater	19.5		Twater	19.2		Twater	20.1		Twater	19.9			
RelHum	30.6		RelHum	22.5		RelHum	23.0		RelHum	25.0		RelHum	26.0			
QNH	1033		QNH	1026		QNH	1027		QNH	1027		QNH	1029			
date	04/02/05		date	07/02/05		date	08/02/05		date	08/02/05		date	09/02/05			
time	10:56		time	16:39		time	09:22		time	14:22		time	09:01			
@precip.	measured		@precip.	measured		@precip.	measured		@precip.	measured		@precip.	measured		@precip.	result
mm/h	deviation		mm/h	deviation		mm/h	deviation		mm/h	deviation		mm/h	deviation		mm/h	deviation
2	2.1	-3.6%	2.0	-3.3%	2.0	-3.6%	2.0	-4.5%	2.0	-3.5%	2.0	-3.6%	2.0	-3.6%	2.0	-3.6%
20	20.2	0.5%	19.9	-0.1%	19.8	-0.1%	19.9	-0.4%	19.7	-0.3%	19.8	-0.1%	19.8	-0.1%	19.8	-0.1%
50	44.3	-1.0%	43.8	0.8%	43.5	0.5%	44.3	0.4%	43.2	-0.3%	43.7	0.2%	43.7	0.2%	43.7	0.2%
90	94.5	-1.2%	88.3	0.1%	90.3	-0.1%	89.6	0.1%	89.9	-0.2%	89.9	-0.1%	89.9	-0.1%	89.9	-0.1%
130	133.4	-1.0%	127.3	-0.1%	128.3	-0.1%	128.4	0.1%	127.2	-0.1%	127.6	-0.1%	127.6	-0.1%	127.6	-0.1%
170	178.7	-1.0%	169.7	0.0%	171.3	-0.4%	171.3	-0.1%	170.8	-0.7%	171.1	-0.4%	171.1	-0.4%	171.1	-0.4%
200	212.0	-1.9%	201.3	-0.2%	204.4	-0.5%	203.8	-0.7%	203.3	-0.9%	203.8	-0.7%	203.8	-0.7%	203.8	-0.7%
252									253.2	-2.0%						
317									323.2	-0.9%						
400									420.6	-1.6%						
Tamb	23.6		Tamb	22.0		Tamb	22.5		Tamb	22.6		Tamb	22.8			
Twater	20.2		Twater	19.2		Twater	20.0		Twater	19.8		Twater	20.5			
RelHum	30.6		RelHum	23.0		RelHum	25.0		RelHum	26.0		RelHum	30.0			
QNH	1033		QNH	1027		QNH	1027		QNH	1029		QNH	1027			
date	04/02/05		date	08/02/05		date	08/02/05		date	09/02/05		date	09/02/05			
time	17:56		time	09:16		time	14:17		time	08:57		time	13:57			

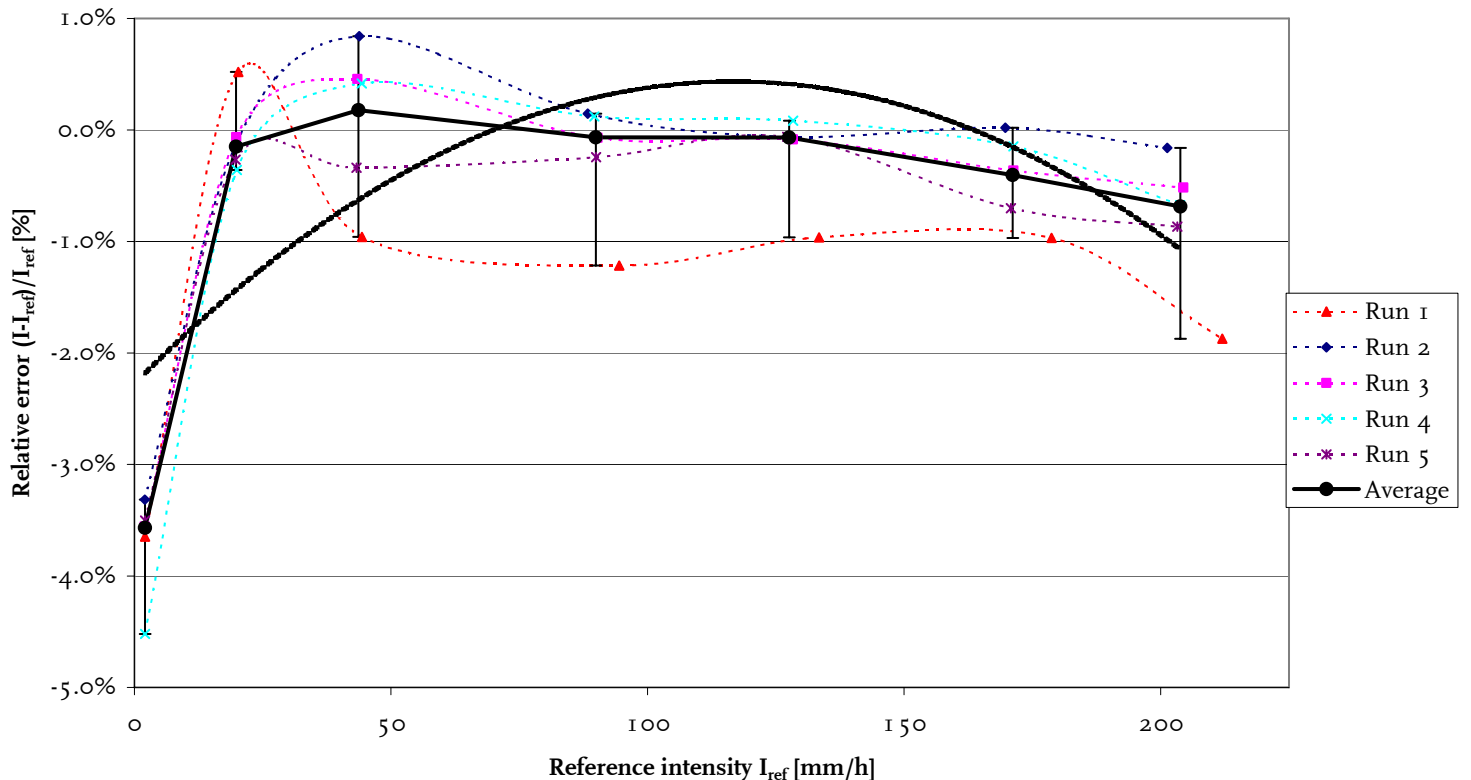



## Appendix 15: Geonor T-200B

Overview of the sensor results derived from the reported accumulated precipitation amount versus the reference and between the 2 instruments. The coefficients of the polynomial fit and the power law fit are reported and the standard error after correction.

Parameter description	Sensor		
	46104	46204	Combined
Average within WMO range (mm/h)	2-600	2-600	-
Standard error sensor 1 versus 2	-	-	1.14%
R <sup>2</sup> measured versus reference	1.0000	1.0000	0.9999
Standard error measured versus reference	2.26%	1.34%	1.86%
Polynomial fit to error a	-7.07E-08	-3.84E-08	-5.41E-08
Error in a	9.43E-08	5.10E-08	5.67E-08
Polynomial fit to error b	0.0001	0.0000	0.0000
Error in b	0.0001	0.0000	0.0000
Polynomial fit to error c	-0.025	-0.016	-0.021
Error in c	0.007	0.003	0.004
Polynomial fit to error R <sup>2</sup>	0.0972	0.1487	0.0778
Standard error after correction	0.89%	0.47%	0.82%
Power law fit a	0.974	0.987	0.980
Error in a	0.010	0.006	0.006
Power law fit b	1.000	1.000	1.001
Error in b	0.002	0.001	0.001
Power law fit R <sup>2</sup>	1.0000	1.0000	0.9999
Standard error measured versus power law	0.91%	0.51%	0.96%

Summary of the average and standard deviation of the running 1-minute averaged reference and measured intensities for all 5 tests.

Reference intensity [mm/h]		46104 intensity [mm/h]		Reference intensity [mm/h]		46204 intensity [mm/h]	
Average	Std. Dev.	Average	Std. Dev.	Average	Std. Dev.	Average	Std. Dev.
2.21	0.12	2.21	0.40	2.24	0.20*	2.10	0.48
23.73	0.64	23.28	1.48	22.88	0.33	22.51	0.79
56.17	1.39	53.37	1.49	54.08	0.73	52.78	1.27
92.87	2.06	91.54	3.35	89.52	1.70	87.69	2.51
132.01	0.85	129.79	2.63	130.93	3.21*	129.30	4.67
168.42	1.10	165.77	3.33	169.12	1.01	167.40	1.63
199.30	0.86	196.03	2.37	198.91	0.79	196.96	1.67
297.89	1.47	293.22	3.60	297.43	1.67	294.55	1.97
425.05	1.61	417.48	4.55	423.38	2.88	418.84	3.15
626.38	2.37	613.20	5.36	624.91	4.30	616.81	5.11

\* During run 1 the reference intensity was 2.6 and 125 mm/h, respectively.

1			2			3			4			5			Difference	
T-200B			T-200B			T-200B			T-200B			T-200B				
run	#1		run	#2		run	#3		run	#4		run	#5			
Ser.nr	46104		Ser.nr	46104		Ser.nr	46104		Ser.nr	46104		Ser.nr	46104			
Tamb	23.2		Tamb	22.6		Tamb	22.7		Tamb	22.0		Tamb	23.0			
Twater	20.2		Twater	19.6		Twater	19.8		Twater	19.8		Twater	20.1			
RelHum	31.0		RelHum	35.0		RelHum	34.0		RelHum	24.0		RelHum	32.0			
QNH	1031		QNH	1032		QNH	1033		QNH	1030		QNH	1032			
date	08/12/04		date	08/12/04		date	08/12/04		date	13/12/04		date	08/12/04			
time	15:07		time	10:13		time	11:29		time	12:44		time	13:56			
@precip.	measured		@precip.	measured		@precip.	measured		@precip.	measured		@precip.	measured		@precip.	result
mm/h	deviation		mm/h	deviation		mm/h	deviation		mm/h	deviation		mm/h	deviation		mm/h	deviation
2	2.2	-5.3% I	2.2	13.5% O		2.2	-5.9% O		2.2	-1.7% I		2.2	-0.3% I		2.2	-2.4% I
20	23.3	-7.3% O	24.6	-0.9% I		24.4	0.6% I		23.0	-3.4% I		23.4	2.1% O		24.0	-1.2% O
50	55.0	-4.8% I	58.1	-4.3% I		57.5	-7.2% O		54.6	-1.8% O		55.7	-4.8% I		56.3	-4.6% I
90	90.6	-0.6% O	95.9	-1.0% I		94.7	-2.4% O		91.2	-2.2% I		92.0	-1.3% I		93.0	-1.5% O
130	131.6	-2.0% O	131.5	-1.3% I		131.2	-1.9% I		132.9	-1.6% I		133.1	-1.1% O		131.9	-1.6% I
170	167.7	-2.7% I	170.0	-1.2% I		167.6	-2.8% O		169.0	-1.8% I		168.3	-0.5% O		168.9	-1.9% O
200	199.8	-1.8% I	199.9	-1.5% I		197.9	-1.7% I		199.5	-2.0% O		199.8	-1.4% O		199.2	-1.7% O
288	297.1	-2.2% I	297.0	-1.1% I		296.2	-1.9% I		299.9	-2.2% O		299.2	-0.4% O		296.8	-1.7% O
416	424.8	-2.6% O	424.0	-1.1% I		423.0	-2.2% I		426.4	-2.1% I		427.2	-0.7% O		424.4	-1.8% O
600	625.4	-2.9% O	625.9	-1.2% O		623.2	-2.3% I		628.2	-2.3% I		628.6	-1.9% I		626.7	-2.1% I
Tamb	23.2		Tamb	22.7		Tamb	22.8		Tamb	22.1		Tamb	23.1			
Twater	20.4		Twater	19.8		Twater	19.8		Twater	19.8		Twater	20.2			
RelHum	30.0		RelHum	34.0		RelHum	32.0		RelHum	23.0		RelHum	31.0			
QNH	1031		QNH	1033		QNH	1032		QNH	1029		QNH	1031			
date	08/12/04		date	08/12/04		date	08/12/04		date	13/12/04		date	08/12/04			
time	16:12		time	11:24		time	12:36		time	13:55		time	15:03			

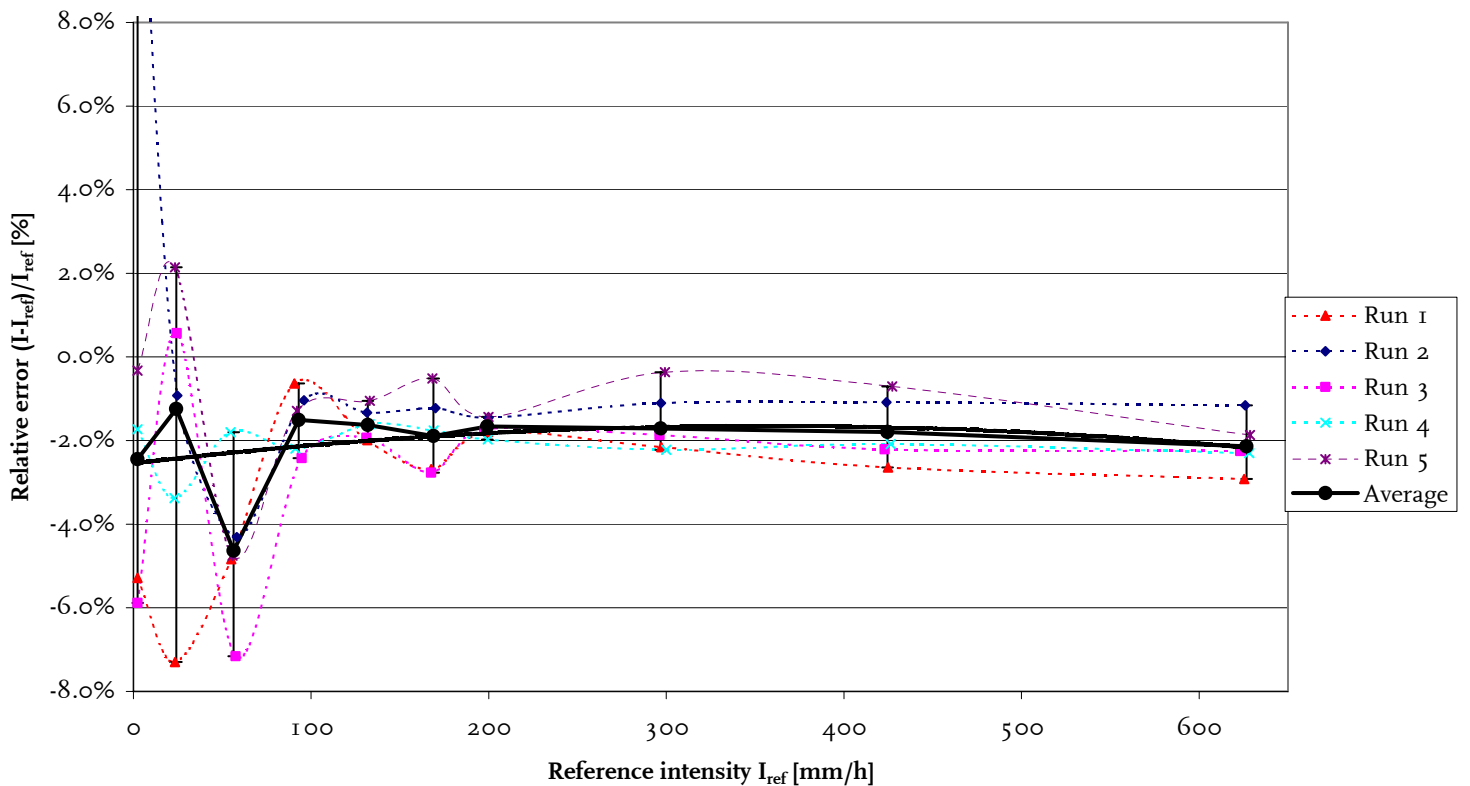

1			2			3			4			5			Difference	
T-200B			T-200B			T-200B			T-200B			T-200B				
run	#1		run	#2		run	#3		run	#4		run	#5			
Ser.nr	46204		Ser.nr	46204		Ser.nr	46204		Ser.nr	46204		Ser.nr	46204			
Tamb	21.4		Tamb	22.2		Tamb	22.5		Tamb	21.0		Tamb	21.3			
Twater	17.4		Twater	19.4		Twater	19.6		Twater	17.6		Twater	17.0			
RelHum	26.0		RelHum	27.0		RelHum	26.0		RelHum	25.0		RelHum	25.0			
QNH	1030		QNH	1028		QNH	1028		QNH	1030		QNH	1030			
date	13/12/04		date	09/12/04		date	09/12/04		date	13/12/04		date	13/12/04			
time	11:00		time	10:06		time	11:27		time	08:38		time	09:51			
@precip.	measured		@precip.	measured		@precip.	measured		@precip.	measured		@precip.	measured		@precip.	result
mm/h	deviation		mm/h	deviation		mm/h	deviation		mm/h	deviation		mm/h	deviation		mm/h	deviation
2	2.5	-27.4%	2.2	-2.5%	2.2	-1.2%	2.1	1.7%	2.2	7.1%	2.2	-0.7%	2.2	-0.7%	2.2	-0.7%
20	23.0	-1.7%	23.1	-2.2%	23.2	-1.3%	22.4	-1.2%	22.8	-2.3%	23.1	-1.7%	23.1	-1.7%	23.1	-1.7%
50	54.5	-3.9%	54.6	-4.7%	54.8	-1.4%	52.8	-1.5%	53.7	-1.6%	53.7	-2.3%	53.7	-2.3%	53.7	-2.3%
90	91.5	-2.9%	90.2	-4.4%	90.2	-0.7%	86.4	-1.1%	89.3	-1.4%	89.1	-1.8%	89.1	-1.8%	89.1	-1.8%
130	124.8	-1.7%	132.6	-1.0%	132.2	-0.6%	131.0	-0.7%	130.5	-0.7%	131.4	-0.8%	131.4	-0.8%	131.4	-0.8%
170	169.1	-1.3%	170.9	-0.8%	168.8	-1.0%	168.4	-1.2%	168.3	-1.0%	168.5	-1.0%	168.5	-1.0%	168.5	-1.0%
200	198.2	-1.1%	199.4	-1.4%	199.6	-0.7%	199.1	-0.8%	198.1	-0.9%	198.5	-0.9%	198.5	-0.9%	198.5	-0.9%
288	295.9	-1.1%	299.6	-1.5%	298.8	-1.0%	297.4	-0.7%	295.4	-0.8%	296.7	-0.9%	296.7	-0.9%	296.7	-0.9%
416	421.1	-1.3%	428.4	-1.1%	426.0	-1.0%	423.2	-0.9%	419.6	-0.9%	424.7	-1.0%	424.7	-1.0%	424.7	-1.0%
600	621.6	-1.6%	629.0	-1.4%	628.4	-1.0%	627.0	-1.0%	618.3	-1.1%	624.8	-1.2%	624.8	-1.2%	624.8	-1.2%
Tamb	21.8		Tamb	22.5		Tamb	22.7		Tamb	21.2		Tamb	21.4			
Twater	18.0		Twater	19.6		Twater	19.9		Twater	17.0		Twater	17.4			
RelHum	24.0		RelHum	26.0		RelHum	26.0		RelHum	25.0		RelHum	26.0			
QNH	1030		QNH	1028		QNH	1027		QNH	1030		QNH	1030			
date	13/12/04		date	09/12/04		date	09/12/04		date	13/12/04		date	13/12/04			
time	12:24		time	11:19		time	12:39		time	09:45		time	10:56			

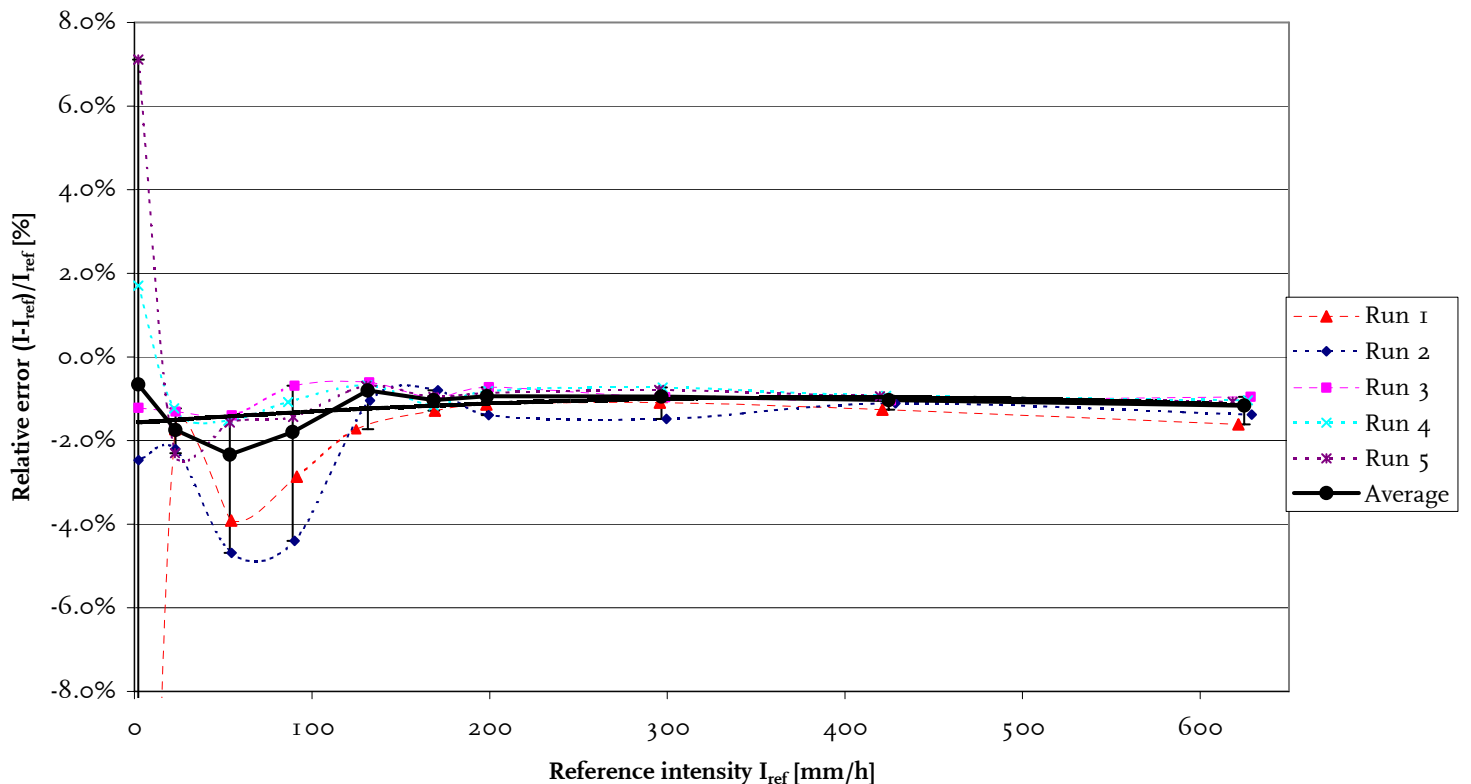

## Appendix 16: MPS System TRwS

Overview of the sensor results derived from the reported intensity versus the reference and between the 2 instruments. The coefficients of the polynomial fit and the power law fit are reported and the standard error after correction.

Parameter description	Sensor		
	A	B	Combined
Average within WMO range (mm/h)	2-600	2-600	-
Standard error sensor 1 versus 2	-	-	0.61%
R <sup>2</sup> measured versus reference	0.9998	0.9997	0.9997
Standard error measured versus reference	0.90%	1.43%	1.19%
Polynomial fit to error a	-1.37E-07	-2.30E-07	-1.84E-07
Error in a	4.04E-08	7.48E-08	4.14E-08
Polynomial fit to error b	0.0001	0.0001	0.0001
Error in b	0.0000	0.0000	0.0000
Polynomial fit to error c	-0.007	-0.015	-0.011
Error in c	0.003	0.005	0.003
Polynomial fit to error R <sup>2</sup>	0.7235	0.6157	0.6048
Standard error after correction	0.39%	0.74%	0.63%
Power law fit a	0.993	0.981	0.987
Error in a	0.008	0.012	0.007
Power law fit b	1.002	1.002	1.001
Error in b	0.002	0.003	0.001
Power law fit R <sup>2</sup>	0.9996	0.9996	0.9997
Standard error measured versus power law	0.74%	1.13%	1.00%

Summary of the average and standard deviation of the running 1-minute averaged reference and measured intensities for all 5 tests.

Reference intensity [mm/h]		A intensity [mm/h]		Reference intensity [mm/h]		B intensity [mm/h]	
Average	Std. Dev.	Average	Std. Dev.	Average	Std. Dev.	Average	Std. Dev.
2.09	0.07	2.03	0.17	2.12	0.11	2.04	0.19
19.81	0.13	19.27	2.20	19.94	0.12	19.50	0.91
52.77	0.52	50.91	5.56	52.31	2.11**	51.91	5.29
96.14	0.42	94.09	7.77	96.70	0.45	94.97	5.55
135.28	0.35	132.24	10.12	136.04	0.36	132.14	12.58
176.98	0.53	172.97	13.12	178.26	0.52	175.10	13.43
208.84	0.54	191.63	49.21*	210.27	0.79	205.59	16.06
280.22	1.57	273.86	22.69	283.41	1.45	273.97	30.39
408.50	1.61	398.37	30.90	412.32	1.19	405.00	26.51
633.80	8.13	612.05	32.57	627.30	20.36**	603.79	47.01

\* During run 1 the sensor showed a delay of 4 minutes.

\*\* During run 2 and 4 the reference intensity was 48 and 586 mm/h respectively.

1			2			3			4			5			Intensity	
TRwS	run #1		TRwS	run #2		TRwS	run #3		TRwS	run #4		TRwS	run #5			
Ser.nr	A		Ser.nr	A		Ser.nr	A		Ser.nr	A		Ser.nr	A			
Tamb	23.3		Tamb	23.3		Tamb	22.1		Tamb	22.6		Tamb	22.8			
Twater	17.2		Twater	16.0		Twater	18.8		Twater	19.5		Twater	17.6			
RelHum	28.4		RelHum	27.2		RelHum	32.0		RelHum	31.1		RelHum	30.5			
QNH	1013		QNH	1011		QNH	999		QNH	998		QNH	998			
date	06/04/05		date	06/04/05		date	07/04/05		date	07/04/05		date	07/04/05			
time	11:53		time	13:33		time	06:50		time	08:45		time	10:37			
@precip.	measured		@precip.	measured		@precip.	measured		@precip.	measured		@precip.	measured		@precip.	result
mm/h	deviation		mm/h	deviation		mm/h	deviation		mm/h	deviation		mm/h	deviation		mm/h	deviation
2	2.1	-0.3%	2.1	-2.1%	I	2.1	-0.5%	I	2.1	-3.1%	O	2.1	-2.2%	I	2.1	-1.6%
20	19.7	0.0%	19.8	-0.3%	I	19.8	0.6%	O	20.0	-0.6%	O	19.7	0.5%	I	19.7	0.1%
50	52.8	0.1%	53.0	-0.9%	O	53.0	-0.3%	I	53.2	-0.1%	I	51.8	0.1%	O	53.0	-0.1%
90	95.4	0.5%	96.3	0.2%	I	96.4	0.0%	I	96.3	-0.4%	I	96.3	-0.7%	O	96.3	-0.1%
130	134.9	-0.5%	135.4	-0.4%	I	135.5	-0.1%	O	135.6	-0.3%	I	134.9	-0.1%	I	135.3	-0.3%
170	176.3	-0.4%	177.0	-0.1%	I	177.4	0.4%	O	177.6	-0.1%	I	176.6	-0.2%	I	177.1	-0.1%
200	207.9	-0.1%	209.2	-0.3%	I	209.2	-0.4%	I	209.0	0.9%	O	208.9	-18.9%	O	208.8	-0.2%
288	277.9	-0.1%	279.0	0.0%	O	282.1	-0.2%	I	281.0	-0.2%	O	280.9	-0.2%	I	280.3	-0.1%
416	406.6	-0.1%	408.4	-0.4%	I	408.6	-0.4%	I	407.6	-0.6%	O	411.2	-0.3%	I	409.4	-0.4%
600	625.1	-0.6%	640.2	-3.1%	I	629.6	-3.1%	I	627.6	-0.4%	O	646.2	-3.5%	O	631.7	-2.3%
Tamb	23.3		Tamb	23.0		Tamb	22.5		Tamb	22.9		Tamb	23.0			
Twater	17.8		Twater	15.5		Twater	19.5		Twater	20.0		Twater	15.5			
RelHum	26.8		RelHum	27.3		RelHum	31.2		RelHum	30.2		RelHum	27.3			
QNH	1011		QNH	999		QNH	998		QNH	998		QNH	999			
date	06/04/05		date	07/04/05		date	07/04/05		date	07/04/05		date	07/04/05			
time	13:28		time	12:53		time	08:31		time	10:21		time	12:53			

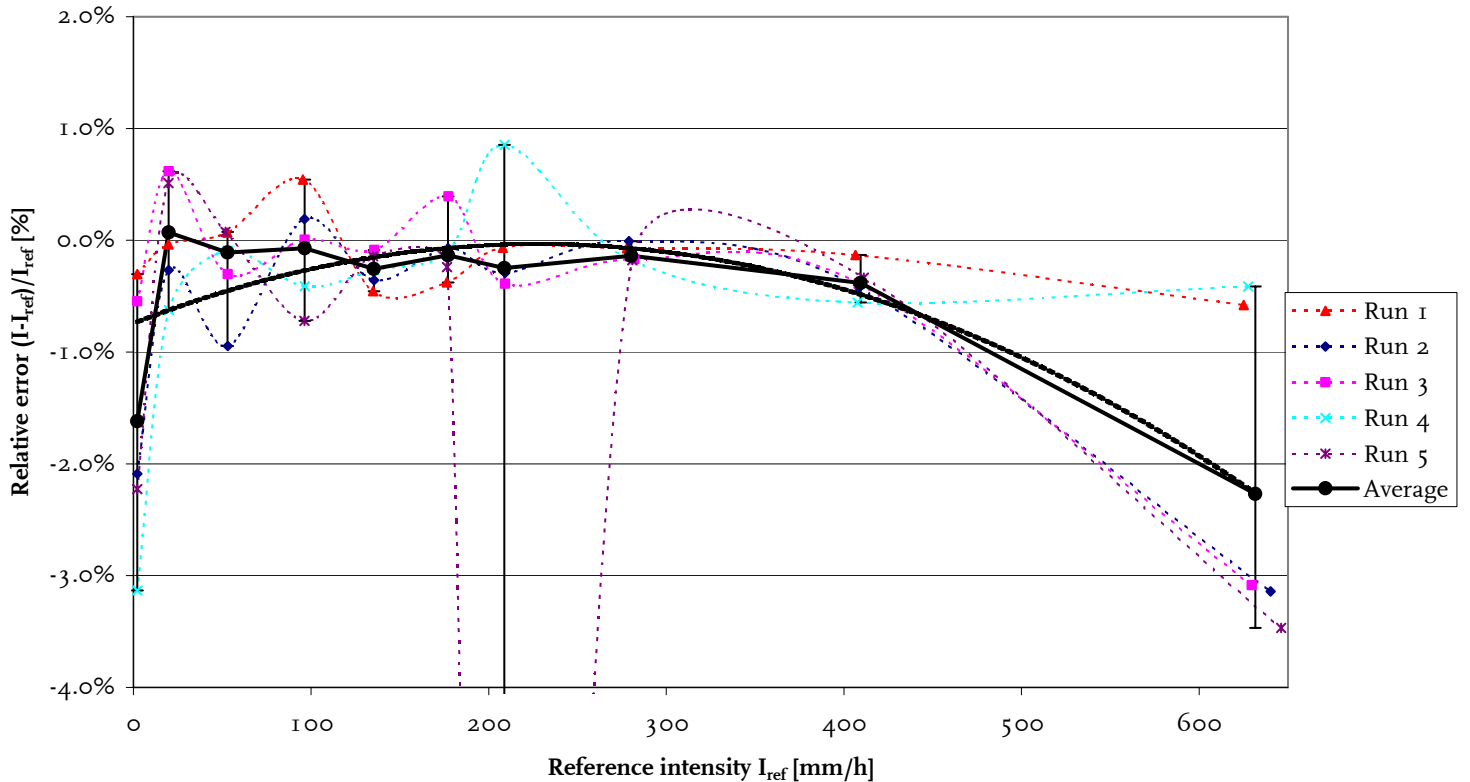

1			2			3			4			5			Intensity	
TRwS 1			TRwS 2			TRwS 3			TRwS 4			TRwS 5				
run	#1		run	#2		run	#3		run	#4		run	#5			
Ser.nr	B		Ser.nr	B		Ser.nr	B		Ser.nr	B		Ser.nr	B			
Tamb	22.3		Tamb	22.7		Tamb	23.0		Tamb	23.1		Tamb	21.7			
Twater	20.0		Twater	20.0		Twater	20.5		Twater	20.2		Twater	18.2			
RelHum	30.9		RelHum	29.9		RelHum	28.2		RelHum	27.6		RelHum	32.8			
QNH	1000		QNH	1001		QNH	1002		QNH	1003		QNH	1028			
date	08/04/05		date	08/04/05		date	08/04/05		date	08/04/05		date	11/04/05			
time	07:09		time	08:46		time	10:33		time	12:40		time	07:10			
@precip.	measured		@precip.	measured		@precip.	measured		@precip.	measured		@precip.	measured		@precip.	result
mm/h	deviation		mm/h	deviation		mm/h	deviation		mm/h	deviation		mm/h	deviation		mm/h	deviation
2	2.1	-3.6% I	2.1	-2.5% I		2.1	-4.5% O		2.1	-3.4% I		2.1	-2.0% O		2.1	-3.2%
20	19.8	-0.5% I	19.9	-0.5% O		20.0	-0.6% I		20.0	-0.6% I		20.1	-0.9% O		19.9	-0.6%
50	53.2	-0.5% O	48.2	11.1% O		54.0	0.5% I		53.2	-0.2% I		53.0	0.9% I		53.4	0.4%
90	96.2	-0.2% I	96.5	-0.4% O		97.0	-0.1% O		96.9	-0.2% I		96.9	-0.4% I		96.7	-0.3%
130	135.7	-0.1% I	135.7	0.3% O		136.1	-0.3% O		136.5	-0.1% I		136.3	-0.3% I		136.1	-0.2%
170	177.7	-0.1% I	178.0	-0.4% O		178.2	-0.3% I		178.2	0.6% O		179.1	-0.1% I		178.4	-0.2%
200	210.0	-0.1% I	209.2	-0.1% I		210.4	1.0% O		210.2	-0.4% O		211.6	-0.4% I		210.2	-0.2%
288	283.8	-0.2% I	284.0	-0.7% O		282.3	-0.1% O		285.4	-0.4% I		281.4	-0.6% I		283.5	-0.4%
416	411.1	-0.5% O	412.6	-0.2% I		412.1	-0.4% I		414.2	-0.3% I		411.3	-0.2% O		413.0	-0.3%
600	632.0	-3.1% I	633.2	-3.2% O		636.3	-3.0% I		588.1	5.3% O		646.6	-3.1% I		638.3	-3.1%
Tamb	22.7		Tamb	22.2		Tamb	22.2		Tamb	23.0		Tamb	22.0			
Twater	20.0		Twater	19.2		Twater	19.2		Twater	20.6		Twater	19.0			
RelHum	30.1		RelHum	33.5		RelHum	33.5		RelHum	25.4		RelHum	33.4			
QNH	1001		QNH	1029		QNH	1029		QNH	1004		QNH	1029			
date	08/04/05		date	11/04/05		date	11/04/05		date	08/04/05		date	11/04/05			
time	08:43		time	09:54		time	09:54		time	14:15		time	08:45			

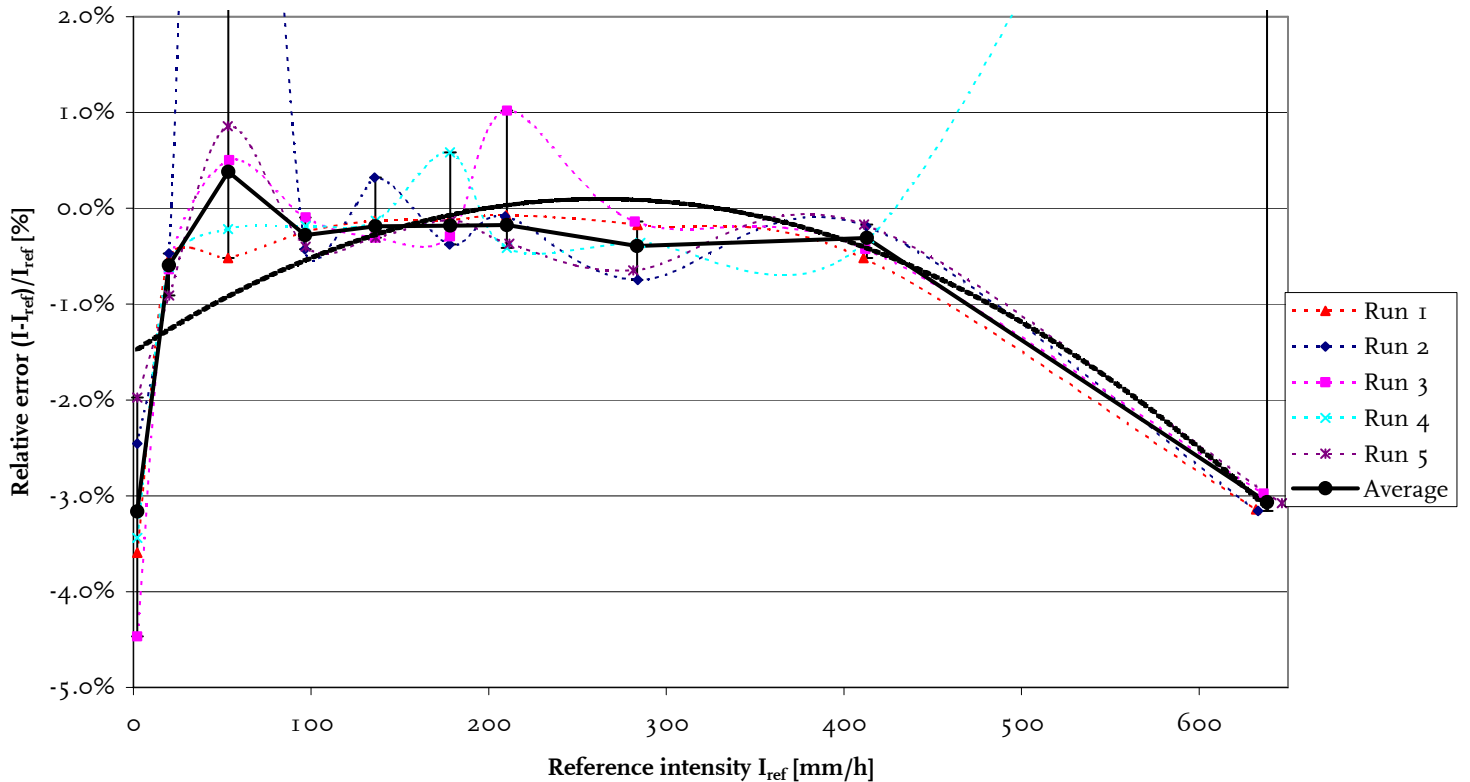

## Appendix 17: Lambrecht 1518H3

Overview of the sensor results derived from the tips versus the reference and between the 2 instruments. The coefficients of the polynomial fit and the power law fit are reported and the standard error after correction.

Parameter description	Sensor		
	681756-5	681920-2	Combined
Average within WMO range (mm/h)	2-50	2-50	-
Standard error sensor 1 versus 2	-	-	4.96%
R <sup>2</sup> measured versus reference	0.9902	0.9976	0.9864
Standard error measured versus reference	18.01%	14.11%	16.17%
Polynomial fit to error a	9.40E-07	1.40E-06	1.20E-06
Error in a	1.89E-07	7.76E-08	1.80E-07
Polynomial fit to error b	-0.0011	-0.0013	-0.0012
Error in b	0.0001	0.0001	0.0001
Polynomial fit to error c	0.025	0.048	0.037
Error in c	0.013	0.006	0.013
Polynomial fit to error R <sup>2</sup>	0.9755	0.9933	0.9345
Standard error after correction	2.29%	0.87%	3.55%
Power law fit a	1.210	1.173	1.191
Error in a	0.087	0.059	0.053
Power law fit b	0.940	0.940	0.932
Error in b	0.014	0.010	0.009
Power law fit R <sup>2</sup>	0.9973	0.9973	0.9883
Standard error measured versus power law	6.35%	4.50%	6.62%

Summary of the average and standard deviation of the reference intensities and the corrected time interval between consecutive tips for all 5 tests.

Reference intensity [mm/h]		681756-5 tip interval [s]		Reference intensity [mm/h]		681920-2 tip interval [s]	
Average	Std. Dev.	Average	Std. Dev.	Average	Std. Dev.	Average	Std. Dev.
2.57	2.15	152.36	5.06	2.44	1.68	150.18	6.16
20.11	2.13	17.79	2.49	20.33	1.74	17.35	2.51
47.99	2.07	7.66	2.50	48.10	1.79	7.47	2.51
96.84	4.06	4.45	1.05	97.38	16.40*	4.38	1.10
141.19	2.70	3.25	1.15	141.08	2.26	3.17	1.11
179.83	3.52	2.42	0.29	180.00	2.89	2.36	0.31
217.10	4.06	2.15	0.41	217.48	3.20	2.07	0.42
309.74	4.30	1.52	0.20	310.35	4.95	1.48	0.21
432.17	9.33	1.15	0.12	437.80	4.23	1.09	0.13
638.70	14.90	0.87	0.10	647.03	6.42	0.69	0.07

\* During run 1 and 2 the reference intensity varied.

1 1518 H3			2 1518 H3			3 1518 H3			4 1518 H3			5 1518 H3			Tips	
run #1	run #2	run #3	run #4	run #5												
Ser.nr 681756-5	Ser.nr 681756-5	Ser.nr 681756-5	Ser.nr 681756-5	Ser.nr 681756-5												
Tamb 24.4	Tamb 24.6	Tamb 24.2	Tamb 26.4	Tamb 25.2												
Twater 19.0	Twater 22.0	Twater 20.0	Twater 23.0	Twater 21.0												
RelHum 37.7	RelHum 38.6	RelHum 47.8	RelHum 42.7	RelHum 41.6												
QNH 1023	QNH 1024	QNH 1018	QNH 1017	QNH 1016												
date 25/05/05	date 25/05/05	date 26/05/05	date 26/05/05	date 27/05/05												
time 08:33	time 12:14	time 06:44	time 10:22	time 07:08												
@precip. mm/h	measured deviation	@precip. mm/h	measured deviation	@precip. mm/h	measured deviation	@precip. mm/h	measured deviation	@precip. mm/h	measured deviation	@precip. mm/h	measured deviation	@precip. mm/h	measured deviation	@precip. mm/h	result deviation	
2 2.3	4.8%	2.3	2.0%	2.3	2.8%	2.4	-0.5%	2.3	2.0%	2.3	2.3%	2.3	2.3%	2.3	2.3%	
20 19.8	1.3%	19.9	1.1%	20.1	4.3%	20.3	3.2%	19.8	-3.4%	20.0	1.8%	19.8	-3.4%	20.0	1.8%	
50 47.4	-0.2%	47.8	-0.2%	48.0	-1.1%	48.3	-1.9%	47.6	-5.1%	48.0	-1.1%	47.6	-5.1%	48.0	-1.1%	
90 95.9	-6.5%	96.4	-10.2%	98.5	-8.2%	95.4	-12.9%	97.6	-8.9%	97.5	-9.1%	97.6	-8.9%	97.5	-9.1%	
130 141.2	-8.2%	140.9	-13.2%	141.5	-14.2%	141.2	-17.0%	140.8	-13.8%	141.1	-13.7%	140.8	-13.8%	141.1	-13.7%	
170 179.9	-11.2%	179.8	-13.7%	180.4	-17.4%	179.0	-19.6%	178.8	-17.8%	179.7	-16.3%	178.8	-17.8%	179.7	-16.3%	
200 217.2	-15.4%	216.5	-18.3%	217.5	-21.0%	217.0	-20.7%	215.8	-22.1%	217.0	-20.0%	215.8	-22.1%	217.0	-20.0%	
288 310.2	-18.4%	309.7	-22.0%	310.4	-21.2%	309.3	-25.6%	308.3	-23.6%	309.5	-22.2%	308.3	-23.6%	309.5	-22.2%	
416 439.4	-26.0%	436.8	-26.3%	440.2	-30.4%	423.4	-25.8%	420.5	-25.8%	433.2	-26.0%	420.5	-25.8%	433.2	-26.0%	
600 650.5	-35.9%	646.0	-40.4%	652.6	-31.3%	623.0	-32.2%	620.8	-32.4%	631.4	-33.5%	620.8	-32.4%	631.4	-33.5%	
Tamb 24.6	Tamb 25.5	Tamb 26.4	Tamb 27.4	Tamb 24.5												
Twater 22.0	Twater 23.0	Twater 23.0	Twater 24.0	Twater 22.0												
RelHum 38.7	RelHum 39.0	RelHum 42.7	RelHum 34.7	RelHum 31.8												
QNH 1024	QNH 1023	QNH 1017	QNH 1016	QNH 1023												
date 25/05/05	date 25/05/05	date 26/05/05	date 26/05/05	date 01/06/05												
time 12:11	time 15:48	time 10:19	time 13:58	time 13:12												

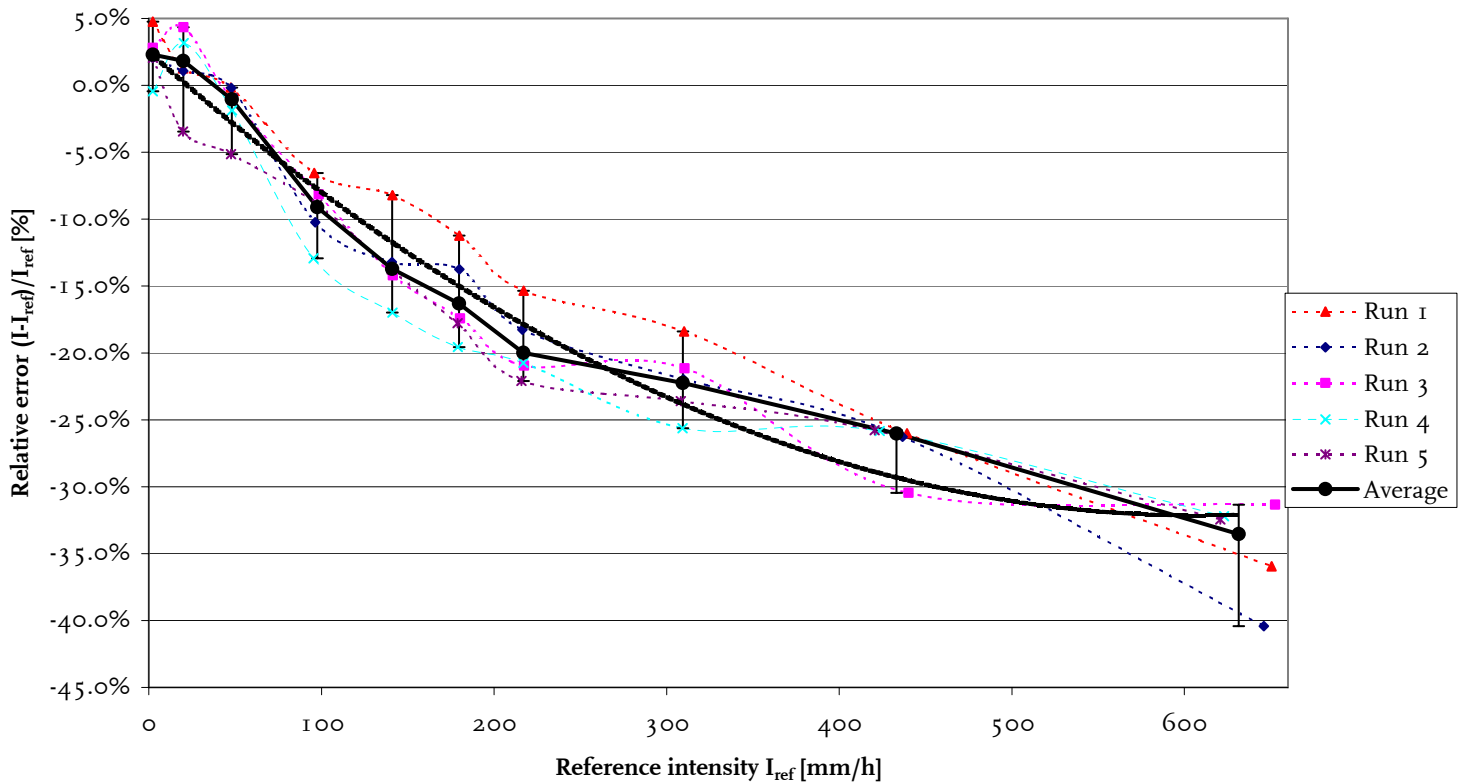

1 I518 H3			2 I518 H3			3 I518 H3			4 I518 H3			5 I518 H3			Tips	
run #1	run #2	run #3	run #4	run #5												
Ser.nr 681920-2	Ser.nr 681920-2	Ser.nr 681920-2	Ser.nr 681920-2	Ser.nr 681920-2												
Tamb 25.0	Tamb 25.7	Tamb 24.4	Tamb 24.7	Tamb 22.5												
Twater 21.7	Twater 22.0	Twater 21.9	Twater 22.3	Twater 21.1												
RelHum 35.9	RelHum 34.9	RelHum 37.6	RelHum 36.6	RelHum 33.9												
QNH 1018	QNH 1019	QNH 1024	QNH 1025	QNH 1025												
date 30/05/05	date 30/05/05	date 31/05/05	date 31/05/05	date 01/06/05												
time 07:06	time 11:45	time 06:39	time 09:57	time 06:50												
@precip. mm/h	measured deviation	@precip. mm/h	measured deviation	@precip. mm/h	measured deviation	@precip. mm/h	measured deviation	@precip. mm/h	measured deviation	@precip. mm/h	measured deviation	@precip. mm/h	measured deviation	@precip. mm/h	result deviation	
2 2.3	6.4%	2.4	1.5%	2.3	4.2%	2.3	5.8%	2.3	3.1%	2.3	4.3%	2.3	4.3%	2.3	4.3%	
20 20.5	6.6%	20.3	4.1%	20.2	-1.9%	19.9	4.4%	20.0	0.7%	20.0	3.1%	20.1	3.1%	20.1	3.1%	
50 48.8	5.9%	48.4	-1.3%	48.0	-3.5%	47.0	2.4%	47.4	-0.8%	47.6	0.1%	47.6	0.1%	47.6	0.1%	
90 99.9	-7.2%	97.7	-8.7%	97.4	-7.6%	94.2	-6.8%	97.2	-7.4%	98.2	-7.4%	98.2	-7.4%	98.2	-7.4%	
130 142.7	-12.4%	140.8	-12.7%	141.3	-11.1%	140.5	-10.9%	139.4	-10.5%	141.5	-11.5%	141.5	-11.5%	141.5	-11.5%	
170 181.9	-13.7%	179.1	-14.2%	180.4	-12.3%	179.7	-13.3%	177.9	-13.5%	179.8	-13.5%	179.8	-13.5%	179.8	-13.5%	
200 219.8	-17.6%	217.0	-18.1%	217.9	-16.2%	216.7	-15.5%	215.1	-16.1%	217.6	-16.7%	217.6	-16.7%	217.6	-16.7%	
288 313.0	-21.5%	309.5	-21.3%	311.2	-18.4%	309.2	-19.1%	308.0	-18.9%	308.9	-19.8%	308.9	-19.8%	308.9	-19.8%	
416 437.0	-23.4%	437.2	-23.8%	440.5	-22.7%	437.6	-24.0%	436.2	-23.7%	436.8	-23.6%	436.8	-23.6%	436.8	-23.6%	
600 644.5	-23.1%	646.7	-22.7%	652.8	-13.5%	646.8	-19.6%	643.4	-15.1%	645.6	-19.1%	645.6	-19.1%	645.6	-19.1%	
Tamb 24.8	Tamb 24.8	Tamb 24.6	Tamb 24.5	Tamb 24.0												
Twater 22.5	Twater 22.5	Twater 22.5	Twater 23.4	Twater 21.3												
RelHum 29.7	RelHum 29.7	RelHum 37.0	RelHum 32.3	RelHum 30.0												
QNH 1025	QNH 1025	QNH 1025	QNH 1025	QNH 1024												
date 31/05/05	date 31/05/05	date 31/05/05	date 31/05/05	date 01/06/05												
time 14:47	time 14:47	time 09:49	time 13:07	time 10:30												

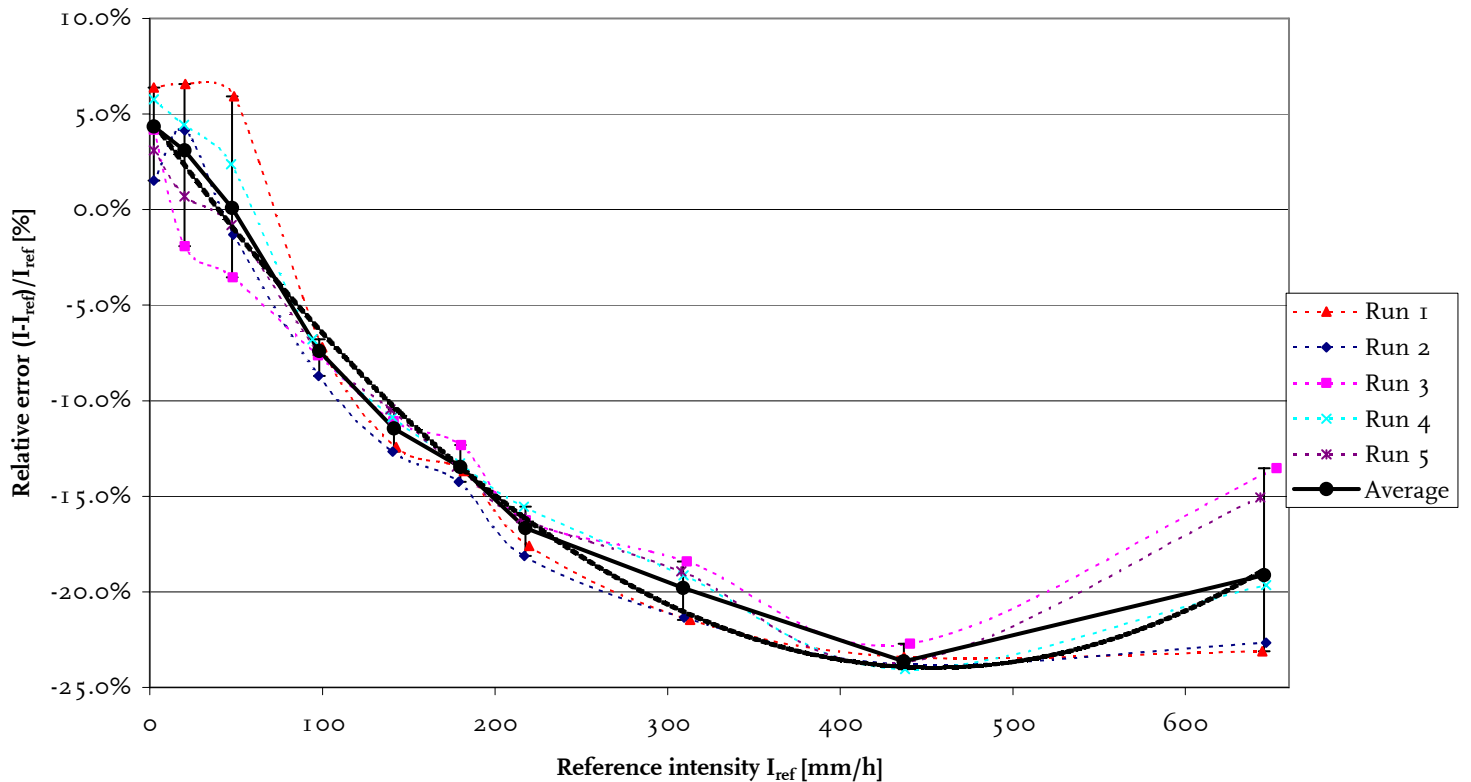

## Appendix 18: Casella CEL Ltd. 100000E

Overview of the sensor results derived from the tips versus the reference and between the 2 instruments. The coefficients of the polynomial fit and the power law fit are reported and the standard error after correction.

Parameter description	Sensor		
	945609	945610	Combined
Average within WMO range (mm/h)	2-50	2-50	-
Standard error sensor 1 versus 2	-	-	1.14%
R <sup>2</sup> measured versus reference	0.9979	0.9979	0.9978
Standard error measured versus reference	10.48%	10.06%	10.27%
Polynomial fit to error a	3.93E-07	1.69E-07	2.82E-07
Error in a	1.72E-07	1.83E-07	1.22E-07
Polynomial fit to error b	-0.0005	-0.0004	-0.0005
Error in b	0.0001	0.0001	0.0001
Polynomial fit to error c	-0.011	-0.024	-0.018
Error in c	0.008	0.008	0.005
Polynomial fit to error R <sup>2</sup>	0.9677	0.9572	0.9578
Standard error after correction	1.04%	1.10%	1.14%
Power law fit a	1.047	1.027	1.037
Error in a	0.043	0.040	0.028
Power law fit b	0.974	0.974	0.971
Error in b	0.008	0.008	0.005
Power law fit R <sup>2</sup>	0.9987	0.9987	0.9988
Standard error measured versus power law	3.70%	3.47%	3.62%

Summary of the average and standard deviation of the reference intensities and the corrected time interval between consecutive tips for all 5 tests.

Reference intensity [mm/h]		945609 tip interval [s]		Reference intensity [mm/h]		945610 tip interval [s]	
Average	Std. Dev.	Average	Std. Dev.	Average	Std. Dev.	Average	Std. Dev.
2.15	0.73	359.50	7.82	2.15	0.73	363.33	17.65*
20.09	0.86	36.17	2.13	20.34	0.83	37.01	2.70
53.22	2.01	13.91	2.18	53.27	1.85	13.92	2.13
97.79	1.95	7.83	2.48	97.46	1.64	7.79	2.50
140.04	2.40	5.63	1.67	138.99	2.58	5.65	1.69
179.25	2.61	4.68	0.84	177.84	2.23	4.67	0.85
210.82	2.36	4.22	1.16	209.38	2.63	4.23	1.16
291.21	3.34	3.11	1.08	291.55	3.73	3.08	1.06
356.40	5.30	2.45	0.26	358.37	6.77	2.43	0.23
483.66	6.75	1.87	0.36	481.94	9.81	1.85	0.35

\* During run 4 the measured intensity varied largely.

1			2			3			4			5			Tips		
I 100000E			I 100000E			I 100000E			I 100000E			I 100000E					
run	#1		run	#2		run	#3		run	#4		run	#5				
Ser.nr	945609		Ser.nr	945609		Ser.nr	945609		Ser.nr	945609		Ser.nr	945609				
Tamb	23.4		Tamb	23.6		Tamb	23.6		Tamb	24.6		Tamb	23.9				
Twater	20.1		Twater	21.1		Twater	21.0		Twater	21.8		Twater	22.1				
RelHum	37.5		RelHum	36.5		RelHum	37.0		RelHum	35.8		RelHum	43.1				
QNH	1009		QNH	1011		QNH	1017		QNH	1016		QNH	1020				
date	14/06/05		date	14/06/05		date	15/06/05		date	15/06/05		date	16/06/05				
time	08:00		time	13:34		time	08:17		time	11:07		time	06:50				
@precip.	measured		@precip.	measured		@precip.	measured		@precip.	measured		@precip.	measured		@precip.	result	
mm/h	deviation		mm/h	deviation		mm/h	deviation		mm/h	deviation		mm/h	deviation		mm/h	deviation	
2	2.1	-2.0%	0	2.1	-2.8%	I	2.1	-4.9%	0	2.1	-3.6%	I	2.1	-3.7%	I	2.1	-3.4%
20	19.8	0.7%	0	19.5	-0.9%	I	20.4	-0.5%	I	20.2	-1.0%	0	20.2	-0.8%	I	20.0	-0.8%
50	53.5	-0.8%	0	53.4	-0.8%	I	53.2	-3.0%	I	53.6	-4.1%	I	52.2	-4.5%	0	53.4	-2.6%
90	98.9	-4.7%	0	98.4	-5.3%	I	97.5	-6.1%	I	97.5	-6.8%	0	96.1	-6.2%	I	97.3	-5.9%
130	140.9	-7.6%	I	141.4	-7.4%	0	138.6	-9.9%	0	139.8	-9.0%	I	139.2	-9.3%	I	140.0	-8.6%
170	180.7	-7.9%	0	180.9	-9.8%	I	178.1	-10.9%	0	179.2	-9.4%	I	177.7	-9.8%	I	179.3	-9.7%
200	211.7	-9.9%	0	213.2	-10.1%	I	209.3	-10.7%	I	210.8	-11.0%	0	209.0	-10.9%	I	210.5	-10.6%
271	292.5	-13.1%	I	293.8	-12.4%	0	288.1	-13.3%	I	291.0	-13.9%	0	290.2	-13.4%	I	290.3	-13.3%
368	358.9	-15.7%	I	352.4	-15.0%	0	361.1	-16.6%	I	356.1	-17.0%	I	353.3	-17.4%	0	358.7	-16.4%
500	479.4	-17.7%	0	478.5	-17.7%	I	492.6	-17.7%	I	487.0	-18.1%	I	480.6	-18.9%	0	486.0	-17.8%
Tamb	23.7		Tamb	23.5		Tamb	25.4		Tamb	23.9		Tamb	23.9				
Twater	21.0		Twater	21.0		Twater	22.3		Twater	22.4		Twater	22.0				
RelHum	37.7		RelHum	37.4		RelHum	37.8		RelHum	42.6		RelHum	42.3				
QNH	1010		QNH	1017		QNH	1015		QNH	1019		QNH	1021				
date	14/06/05		date	15/06/05		date	15/06/05		date	16/06/05		date	16/06/05				
time	11:45		time	08:05		time	13:35		time	05:23		time	11:28				

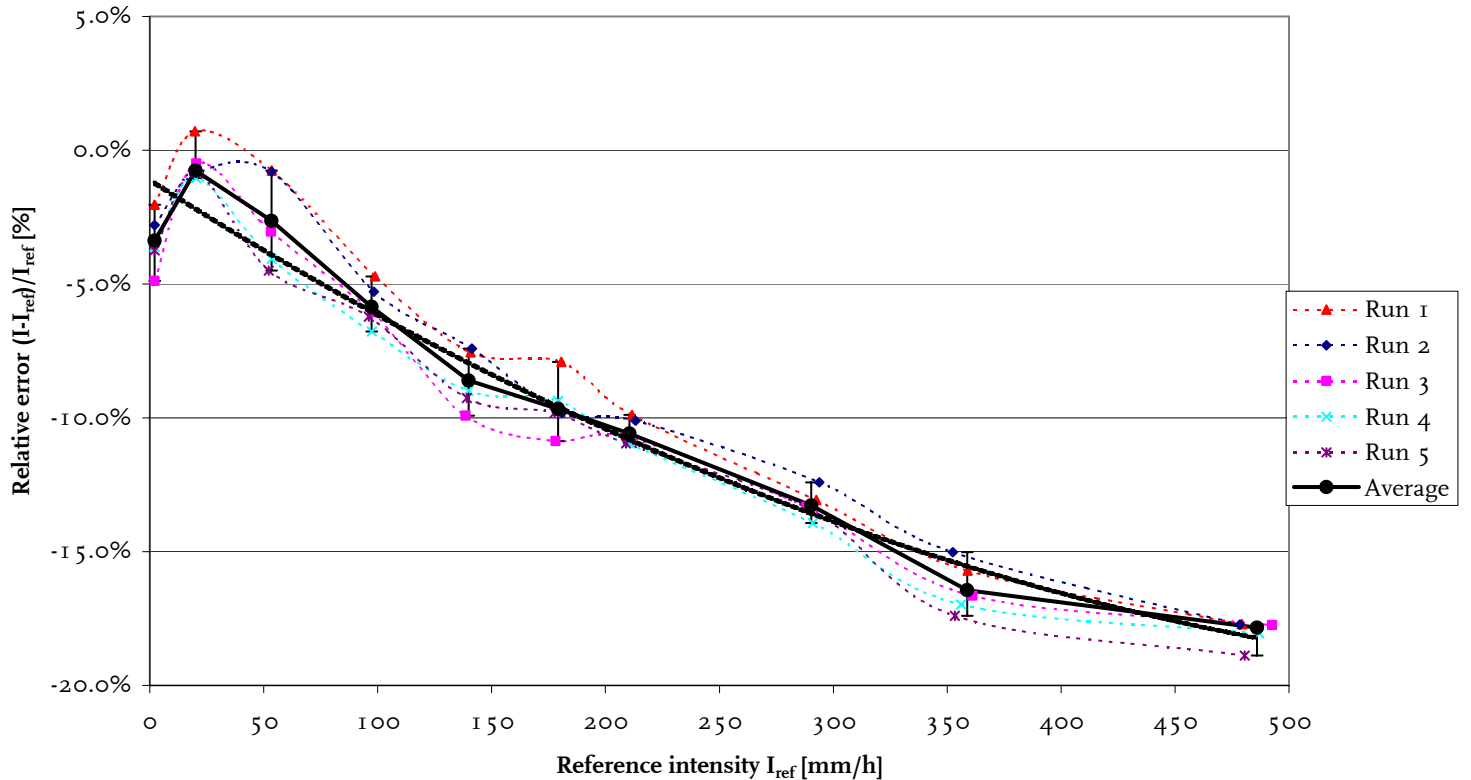

1			2			3			4			5			Tips		
I 100000E			I 100000E			I 100000E			I 100000E			I 100000E					
run	#1		run	#2		run	#3		run	#4		run	#5				
Ser.nr	945610		Ser.nr	945610		Ser.nr	945610		Ser.nr	945610		Ser.nr	945610				
Tamb	24.2		Tamb	24.7		Tamb	24.7		Tamb	24.2		Tamb	26.0				
Twater	22.0		Twater	22.3		Twater	22.3		Twater	23.1		Twater	24.0				
RelHum	42.0		RelHum	40.3		RelHum	40.3		RelHum	58.3		RelHum	47.7				
QNH	1021		QNH	1022		QNH	1022		QNH	1026		QNH	1015				
date	16/06/05		date	16/06/05		date	16/06/05		date	17/06/05		date	20/06/05				
time	11:49		time	14:10		time	14:10		time	11:39		time	07:04				
@precip.	measured		@precip.	measured		@precip.	measured		@precip.	measured		@precip.	measured		@precip.	result	
mm/h	deviation		mm/h	deviation		mm/h	deviation		mm/h	deviation		mm/h	deviation		mm/h	deviation	
2	2.1	-4.8%	I	2.1	-3.4%	I	2.1	-3.2%	I	2.1	-8.8%	O	2.1	-1.4%	O	2.1	-3.8%
20	20.4	-3.7%	I	20.2	-4.0%	I	20.3	-2.9%	O	20.3	-5.7%	O	20.2	-3.8%	I	20.3	-3.8%
50	53.6	-3.7%	I	52.9	-1.5%	O	53.4	-3.8%	O	52.8	-3.2%	I	53.3	-1.8%	I	53.2	-2.9%
90	98.1	-6.3%	O	98.6	-4.1%	I	97.1	-5.6%	I	96.3	-5.7%	I	96.9	-3.6%	O	97.3	-5.1%
130	140.2	-7.1%	O	140.0	-8.1%	I	138.4	-9.3%	I	136.8	-9.4%	O	139.0	-7.4%	I	139.2	-8.2%
170	178.8	-6.5%	O	179.2	-8.1%	I	177.6	-9.9%	O	175.4	-9.6%	I	177.9	-7.9%	I	177.5	-8.5%
200	210.3	-8.9%	O	211.2	-10.1%	I	209.2	-10.7%	I	206.1	-10.8%	O	209.7	-9.0%	I	210.0	-9.9%
271	293.0	-12.7%	I	293.8	-13.2%	O	291.3	-13.0%	I	286.6	-12.6%	I	292.7	-12.1%	O	290.3	-12.7%
368	350.8	-15.3%	O	354.1	-16.5%	I	359.7	-16.7%	I	362.9	-17.7%	O	363.9	-15.8%	I	359.2	-16.3%
500	470.3	-16.0%	I	478.7	-17.4%	I	476.6	-16.9%	I	490.7	-18.5%	O	493.6	-15.7%	O	475.2	-16.7%
Tamb	24.7		Tamb	24.8		Tamb	24.2		Tamb	26.0		Tamb	27.9				
Twater	22.3		Twater	23.0		Twater	23.1		Twater	22.0		Twater	24.4				
RelHum	40.3		RelHum	55.3		RelHum	58.7		RelHum	47.2		RelHum	41.2				
QNH	1022		QNH	1024		QNH	1026		QNH	1015		QNH	1014				
date	16/06/05		date	17/06/05		date	17/06/05		date	20/06/05		date	20/06/05				
time	15:30		time	07:33		time	11:37		time	07:01		time	11:24				

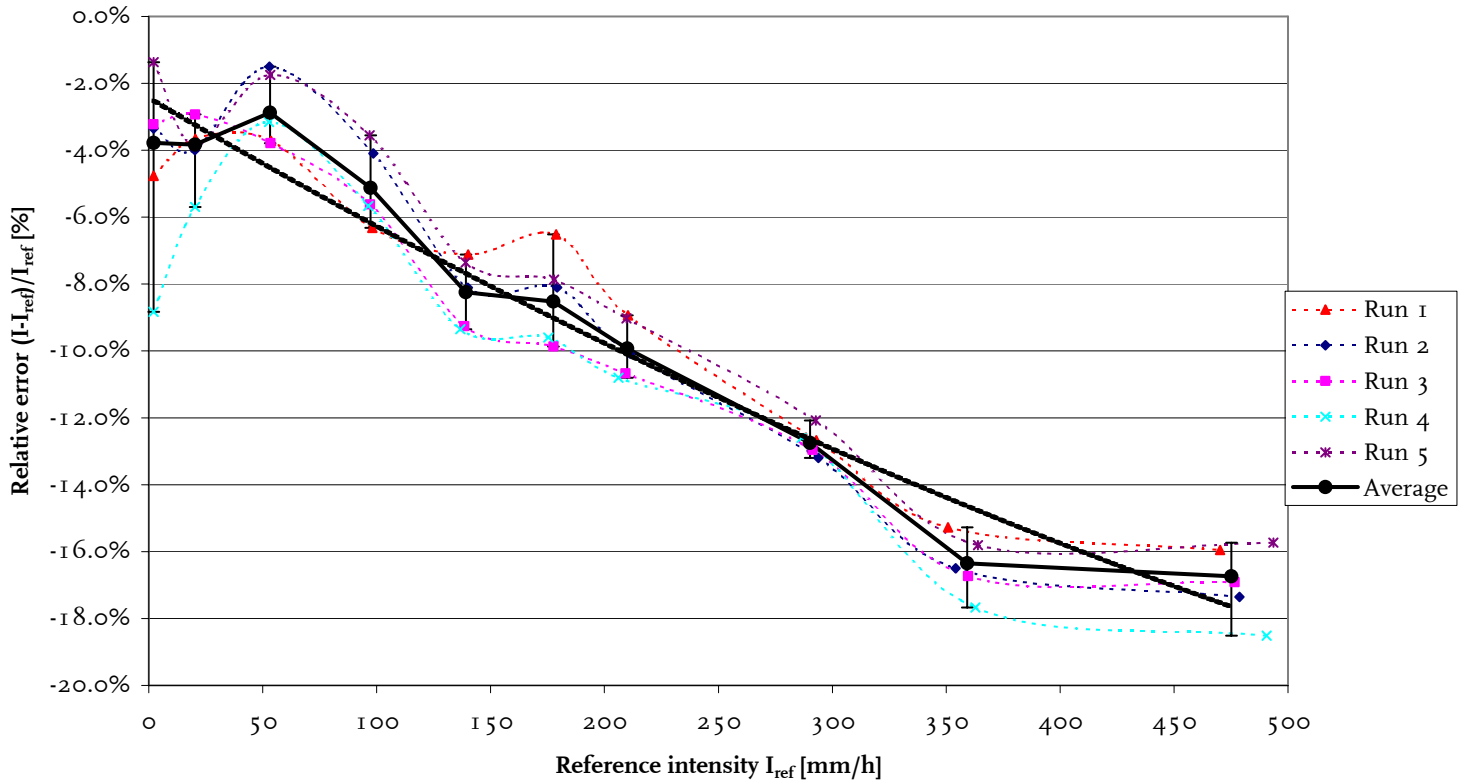

## Appendix 19: Design Analysis Ass. H-340SDI

Overview of the sensor results derived from the corrected and raw tips versus the reference and between the 2 instruments. The coefficients of the polynomial fit and the power law fit are reported and the standard error after correction.

Parameter description	Sensor		
	1737D	Raw	Combined
Average within WMO range (mm/h)	20-50	130-294	-
Standard error sensor 1 versus 2	-	-	-
R <sup>2</sup> measured versus reference	0.9992	0.9942	-
Standard error measured versus reference	7.86%	8.52%	-
Polynomial fit to error a	-3.36E-07	3.70E-07	-
Error in a	1.84E-07	1.54E-07	-
Polynomial fit to error b	0.0003	-0.0006	-
Error in b	0.0001	0.0001	-
Polynomial fit to error c	0.034	0.122	-
Error in c	0.013	0.011	-
Polynomial fit to error R <sup>2</sup>	0.6561	0.9677	-
Standard error after correction	1.68%	1.44%	-
Power law fit a	1.022	1.246	-
Error in a	0.026	0.058	-
Power law fit b	0.955	0.955	-
Error in b	0.005	0.009	-
Power law fit R <sup>2</sup>	0.9967	0.9967	-
Standard error measured versus power law	2.30%	4.21%	-

Summary of the average and standard deviation of the reference intensities and the corrected time interval between consecutive tips for all 5 tests.

Reference intensity [mm/h]		1737D tip interval [s]		Reference intensity [mm/h]		tip interval [s]	
Average	Std. Dev.	Average	Std. Dev.	Average	Std. Dev.	Average	Std. Dev.
2.23	0.76	400.05	32.94				
19.65	0.93	46.33	7.07				
44.99	1.16	21.07	5.37				
97.22	5.37	8.79	2.32				
139.37	4.38	6.42	2.30				
181.44	4.48	4.75	0.71				
210.00	4.63	4.26	0.83				
305.60	13.55*	3.07	1.08				
428.58	9.40	1.93	0.27				
635.19	4.63	4.26	0.83				
831.58	26.38	1.07	0.15				
1219.44	68.39	0.75	0.14				
2050.60	82.74	0.47	0.06				

\* During run 3 the reference intensity was only 287 mm/h.

1			2			3			4			5			Corrected		
H-340SDI			H-340SDI			H-340SDI			H-340SDI			H-340SDI					
run	#1		run	#2		run	#3		run	#4		run	#5				
Ser.nr	1737D		Ser.nr	1737D		Ser.nr	1737D		Ser.nr	1737D		Ser.nr	1737D				
Tamb	24.3		Tamb	23.4		Tamb	20.7		Tamb	22.2		Tamb	21.7				
Twater	22.1		Twater	20.3		Twater	16.9		Twater	18.9		Twater	18.5				
RelHum	45.8		RelHum	52.9		RelHum	34.8		RelHum	29.9		RelHum	33.6				
QNH	1015		QNH	1010		QNH	1032		QNH	1034		QNH	1037				
date	02/06/05		date	03/06/05		date	07/06/05		date	07/06/05		date	08/06/05				
time	07:56		time	07:21		time	07:07		time	11:17		time	05:25				
@precip.	measured		@precip.	measured		@precip.	measured		@precip.	measured		@precip.	measured		@precip.	result	
mm/h	deviation		mm/h	deviation		mm/h	deviation		mm/h	deviation		mm/h	deviation		mm/h	deviation	
2	2.1	16.0%	o	2.2	4.1%	I	2.2	6.7%	I	2.2	7.1%	I	2.1	-0.9%	o	2.2	6.0%
20	19.7	12.6%	o	19.7	4.4%	I	19.6	4.3%	I	19.5	-22.2%	o	19.4	5.5%	I	19.6	4.7%
50	45.5	13.8%	o	45.1	6.4%	I	44.9	-8.5%	I	44.8	-34.1%	o	44.3	5.2%	I	44.8	1.0%
90	99.1	14.4%	o	99.1	9.5%	I	92.8	9.5%	I	96.9	0.1%	o	98.3	1.9%	I	96.7	6.9%
130	140.9	12.3%	o	142.1	6.5%	I	132.0	9.7%	I	138.5	-21.7%	o	142.8	5.3%	I	139.0	7.2%
170	183.4	13.0%	o	184.1	7.4%	I	175.5	6.7%	I	179.1	1.9%	o	184.5	6.5%	I	181.3	6.9%
200	212.2	12.7%	o	212.4	8.7%	I	204.1	9.3%	I	207.1	6.5%	o	213.6	7.3%	I	210.0	8.4%
294	311.8	12.2%	o	309.7	8.6%	I	287.3	10.0%	I	305.5	7.6%	o	315.4	8.0%	I	304.2	8.9%
432	439.3	13.7%	I	427.2	9.1%	o	425.5	9.7%	I	425.3	17.3%	o	427.1	17.1%	I	430.6	13.5%
635	649.1	10.9%	o	626.6	6.5%	o	634.1	9.3%	I	634.5	10.0%	I	637.5	7.6%	I	635.4	8.9%
800	854.0	3.4%	I	827.6	1.8%	o	823.6	2.6%	I	821.5	9.1%	o	842.2	2.7%	I	839.9	2.9%
1095	1244.9	1.9%	I	1217.0	1.1%	I	1217.0	-1.7%	o	1229.8	0.6%	I	1225.3	4.4%	o	1230.6	1.2%
2000	2130.0	-7.8%	o	2047.2	-2.1%	o	2025.2	-5.0%	I	2038.9	-2.6%	I	2045.7	-3.7%	I	2036.6	-3.7%
Tamb	24.3		Tamb	25.2		Tamb	21.7		Tamb	21.7		Tamb	22.3				
Twater	22.5		Twater	22.7		Twater	18.5		Twater	18.5		Twater	19.4				
RelHum	48.3		RelHum	50.1		RelHum	33.6		RelHum	33.6		RelHum	32.6				
QNH	1015		QNH	1008		QNH	1037		QNH	1037		QNH	1037				
date	02/06/05		date	03/06/05		date	08/06/05		date	08/06/05		date	08/06/05				
time	15:40		time	12:22		time	05:21		time	05:21		time	09:54				

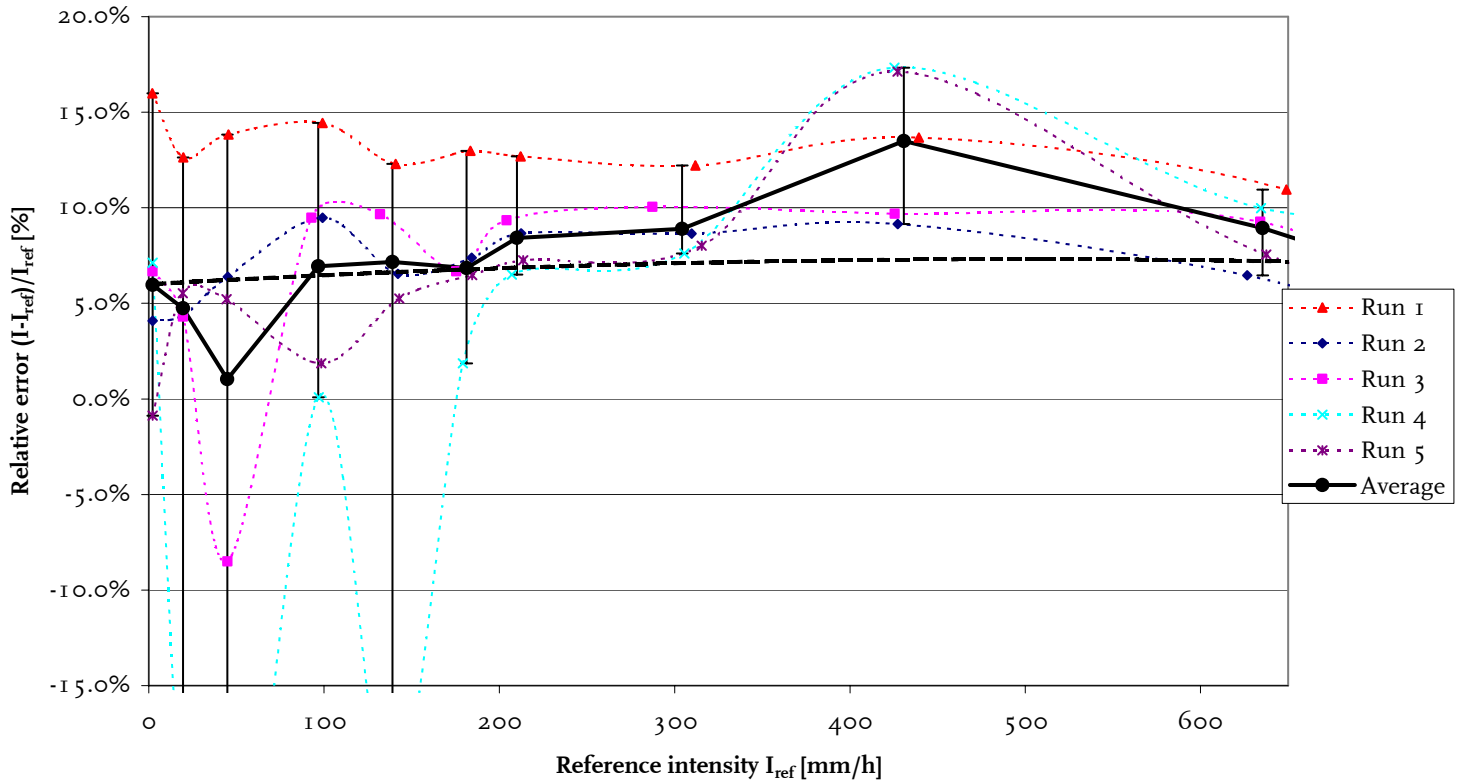

1			2			3			4			5			Tips		
H-340SDI			H-340SDI			H-340SDI			H-340SDI			H-340SDI					
run	#1		run	#2		run	#3		run	#4		run	#5				
Ser.nr	1737D		Ser.nr	1737D		Ser.nr	1737D		Ser.nr	1737D		Ser.nr	1737D				
Tamb	24.3		Tamb	23.4		Tamb	20.7		Tamb	22.2		Tamb	21.7				
Twater	22.1		Twater	20.3		Twater	16.9		Twater	18.9		Twater	18.5				
RelHum	45.8		RelHum	52.9		RelHum	34.8		RelHum	29.9		RelHum	33.6				
QNH	1015		QNH	1010		QNH	1032		QNH	1034		QNH	1037				
date	02/06/05		date	03/06/05		date	07/06/05		date	07/06/05		date	08/06/05				
time	07:56		time	07:21		time	07:07		time	11:17		time	05:25				
@precip.	measured		@precip.	measured		@precip.	measured		@precip.	measured		@precip.	measured		@precip.	result	
mm/h	deviation		mm/h	deviation		mm/h	deviation		mm/h	deviation		mm/h	deviation		mm/h	deviation	
2	2.1	24.5%	o	2.2	11.7%	I	2.2	14.5%	I	2.2	15.0%	I	2.1	6.4%	o	2.2	13.8%
20	19.7	20.2%	o	19.7	11.5%	I	19.6	11.5%	I	19.5	-16.5%	o	19.4	12.8%	I	19.6	12.0%
50	45.5	18.9%	o	45.1	11.4%	I	44.9	-3.7%	I	44.8	-30.0%	o	44.3	10.4%	I	44.8	6.0%
90	99.1	14.1%	o	99.1	9.6%	I	92.8	10.1%	I	96.9	1.0%	o	98.3	2.5%	I	96.7	7.4%
130	140.9	8.4%	o	142.1	3.4%	I	132.0	6.9%	I	138.5	-21.6%	o	142.8	2.2%	I	139.0	4.1%
170	183.4	5.6%	o	184.1	0.9%	I	175.5	1.4%	I	179.1	-3.3%	o	184.5	0.2%	I	181.3	0.9%
200	212.2	3.2%	o	212.4	0.4%	I	204.1	1.5%	I	207.1	-1.3%	o	213.6	-1.2%	I	210.0	0.2%
294	311.8	-2.7%	o	309.7	-5.4%	I	287.3	-3.4%	I	305.5	-5.7%	I	315.4	-5.9%	o	300.8	-4.9%
432	439.3	-7.0%	I	427.2	-9.6%	o	425.5	-9.2%	I	425.3	-3.9%	o	427.1	-4.1%	I	430.6	-6.8%
635	649.1	-13.5%	o	626.6	-16.2%	o	634.1	-14.4%	I	634.5	-13.9%	I	637.5	-15.6%	I	635.4	-14.6%
800	854.0	-19.8%	I	827.6	-21.0%	o	823.6	-20.3%	I	821.5	-15.5%	o	842.2	-20.2%	I	839.9	-20.1%
1095	1244.9	-21.0%	I	1217.0	-21.6%	I	1217.0	-23.7%	o	1229.8	-21.9%	I	1225.3	-19.0%	o	1230.6	-21.5%
2000	2130.0	-28.4%	o	2047.2	-24.0%	o	2025.2	-26.2%	I	2038.9	-24.3%	I	2045.7	-25.2%	I	2036.6	-25.2%
Tamb	24.3		Tamb	25.2		Tamb	21.7		Tamb	21.7		Tamb	22.3				
Twater	22.5		Twater	22.7		Twater	18.5		Twater	18.5		Twater	19.4				
RelHum	48.3		RelHum	50.1		RelHum	33.6		RelHum	33.6		RelHum	32.6				
QNH	1015		QNH	1008		QNH	1037		QNH	1037		QNH	1037				
date	02/06/05		date	03/06/05		date	08/06/05		date	08/06/05		date	08/06/05				
time	15:40		time	12:22		time	05:21		time	05:21		time	09:54				

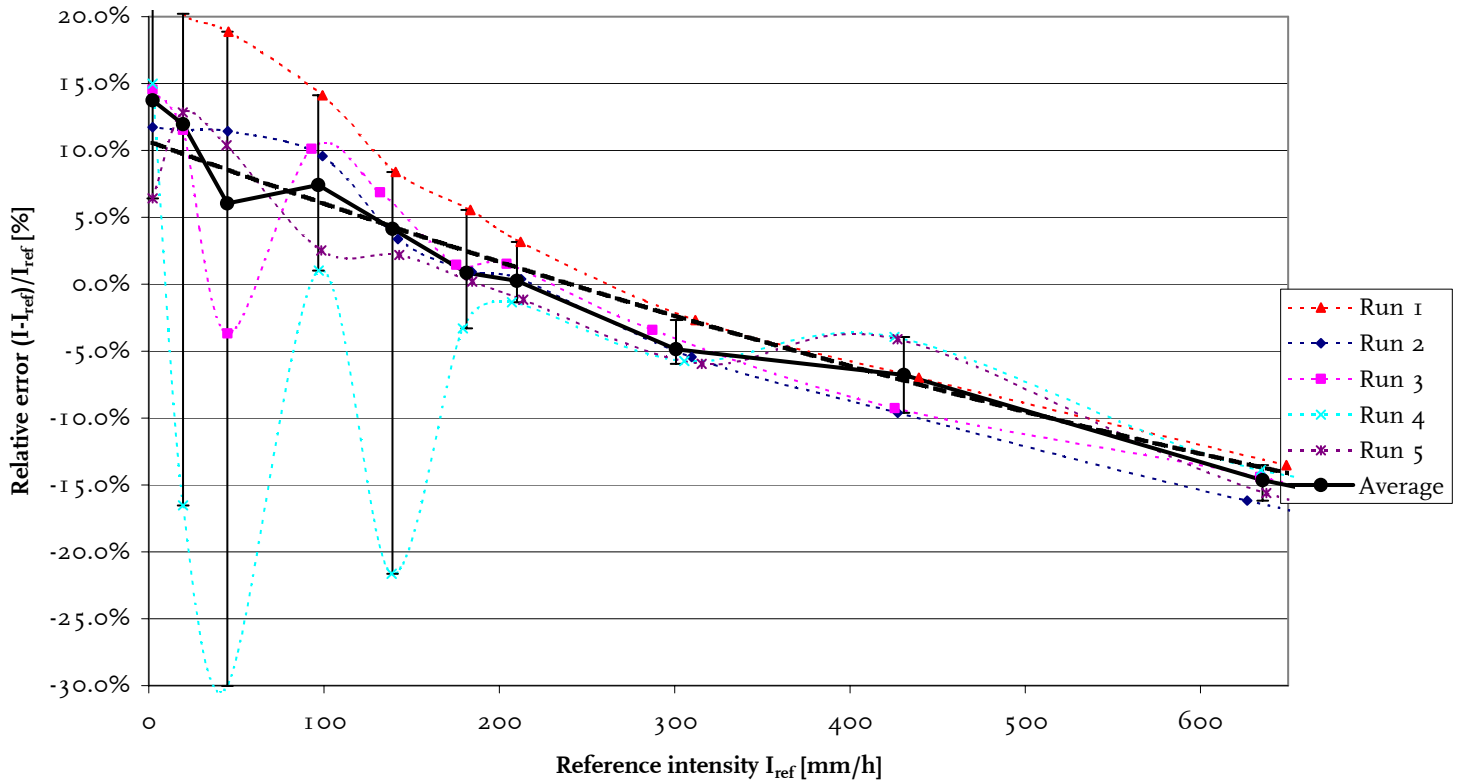

## Appendix 20: KNMI Neerslagmeter

Overview of the raw sensor results derived from the reported intensity versus the reference and between the 2 instruments. The coefficients of the polynomial fit and the power law fit are reported and the standard error after correction.

Parameter description	Sensor		
	061-03	061-04	Combined
Average within WMO range (mm/h)	2-130	2-130	-
Standard error sensor 1 versus 2	-	-	1.32%
R <sup>2</sup> measured versus reference	0.9977	0.9990	0.9981
Standard error measured versus reference	6.99%	5.97%	6.50%
Polynomial fit to error a	-5.00E-07	-2.27E-07	-3.50E-07
Error in a	3.66E-07	3.46E-07	2.89E-07
Polynomial fit to error b	-0.0003	-0.0003	-0.0003
Error in b	0.0001	0.0001	0.0001
Polynomial fit to error c	0.016	0.011	0.014
Error in c	0.007	0.006	0.005
Polynomial fit to error R <sup>2</sup>	0.9769	0.9679	0.9575
Standard error after correction	0.77%	0.73%	0.97%
Power law fit a	1.071	1.051	1.061
Error in a	0.039	0.031	0.024
Power law fit b	0.978	0.978	0.976
Error in b	0.008	0.006	0.005
Power law fit R <sup>2</sup>	0.9994	0.9994	0.9988
Standard error measured versus power law	3.20%	2.64%	3.03%

Summary of the average and standard deviation of the running 1-minute averaged reference and measured intensities for all 5 tests.

Reference intensity [mm/h]		061-03 intensity [mm/h]		Reference intensity [mm/h]		061-04 intensity [mm/h]	
Average	Std. Dev.	Average	Std. Dev.	Average	Std. Dev.	Average	Std. Dev.
2.10	0.10	2.08	0.28	2.00	0.10	1.98	0.19
20.34	0.17	20.05	1.58	20.59	0.20	20.23	1.60
52.74	0.75	52.03	4.10	52.88	0.34	52.01	3.67
97.37	0.84	94.15	7.64	97.56	0.52	94.01	8.39
138.64	1.24	129.66	14.72	138.84	0.59	132.16	12.37
177.80	1.58	163.82	21.53	177.99	0.69	164.05	21.27
209.64	1.74	190.88	27.58	210.02	0.61	186.33	32.94
241.79	1.76	214.83	36.73	242.80	1.01	216.95	36.15
277.99	2.15	249.93	40.91	279.49	0.94	250.85	41.47
287.81	2.50	254.33	46.72	289.49	1.13	255.68	43.77

Overview of the corrected sensor results derived from the reported intensity versus the reference and between the 2 instruments. The coefficients of the polynomial fit and the power law fit are reported and the standard error after correction.

Parameter description	Sensor		
	061-03	061-04	Combined
Average within WMO range (mm/h)	2-270	2-270	-
Standard error sensor 1 versus 2	-	-	0.37%
R <sup>2</sup> measured versus reference	1.0000	1.0000	1.0000
Standard error measured versus reference	1.01%	0.77%	0.90%
Polynomial fit to error a	4.71E-08	-7.97E-08	-1.68E-08
Error in a	7.67E-08	1.16E-07	8.33E-08
Polynomial fit to error b	0.0000	0.0000	0.0000
Error in b	0.0000	0.0000	0.0000
Polynomial fit to error c	0.010	0.003	0.007
Error in c	0.001	0.002	0.001
Polynomial fit to error R <sup>2</sup>	0.0928	0.3926	0.1433
Standard error after correction	0.15%	0.24%	0.26%
Power law fit a	1.008	1.000	1.004
Error in a	0.002	0.002	0.002
Power law fit b	1.002	1.002	1.001
Error in b	0.000	0.000	0.000
Power law fit R <sup>2</sup>	1.0000	1.0000	1.0000
Standard error measured versus power law	0.15%	0.17%	0.30%

1			2			3			4			5			Intensity		
KNMI #1			KNMI #2			KNMI #3			KNMI #4			KNMI #5					
run	ser.nr	Tamb	run	ser.nr	Tamb	run	ser.nr	Tamb	run	ser.nr	Tamb	run	ser.nr	Tamb			
061-03	23.6	21.0	061-03	23.6	21.2	061-03	24.1	21.9	061-03	22.6	21.0	061-03	23.6	23.0			
45.6	1008	1008	38.1	1009	1009	39.8	1009	1009	51.1	1014	1014	56.6	1029	1029			
07/07/05	08:32	07/07/05	10:38	07/07/05	12:13	07/07/05	08:07/05	06:55	11/07/05	06:13							
@precip.	measured		@precip.	measured		@precip.	measured		@precip.	measured		@precip.	measured		@precip.	result	
mm/h	deviation		mm/h	deviation		mm/h	deviation		mm/h	deviation		mm/h	deviation		mm/h	deviation	
2	2.1	-0.7%	I	2.1	4.0%	O	2.1	1.4%	I	2.1	-1.5%	O	2.1	1.4%	I	2.1	0.7%
20	20.3	0.0%	O	20.5	1.9%	I	20.1	2.3%	O	20.3	1.0%	I	20.5	1.0%	I	20.4	1.3%
50	52.4	0.9%	I	52.1	1.0%	I	52.7	1.1%	O	52.3	1.1%	I	54.0	0.8%	O	52.3	1.0%
90	96.3	1.1%	I	96.9	1.2%	O	97.6	0.8%	I	97.4	0.8%	O	98.7	1.0%	I	97.5	1.0%
130	137.3	0.9%	O	137.8	0.7%	I	138.3	0.6%	O	138.8	0.8%	I	140.6	0.9%	I	139.1	0.8%
170	176.1	1.1%	I	176.6	1.0%	I	177.3	1.1%	I	179.1	0.6%	O	180.5	1.1%	O	176.7	1.1%
200	208.4	0.7%	O	208.1	0.9%	I	208.7	0.7%	I	210.3	0.9%	I	212.7	1.1%	O	209.0	0.9%
229	241.4	0.4%	O	240.5	1.1%	I	241.3	1.2%	O	242.7	1.0%	I	244.5	1.1%	I	242.6	1.1%
262	276.2	1.0%	O	276.2	1.0%	I	277.4	1.1%	I	278.5	1.2%	I	281.9	1.3%	O	277.4	1.1%
270	285.6	1.1%	I	285.7	1.0%	O	287.3	1.2%	O	288.3	1.1%	I	292.3	1.2%	I	288.7	1.1%
Tamb	23.6	Tamb	24.0	Tamb	24.2	Tamb	23.4	Tamb	24.2								
Twater	21.2	Twater	21.9	Twater	22.1	Twater	21.1	Twater	22.7								
RelHum	38.4	RelHum	39.8	RelHum	38.9	RelHum	51.2	RelHum	55.5								
QNH	1009	QNH	1009	QNH	1010	QNH	1015	QNH	1029								
date	07/07/05	date	07/07/05	date	07/07/05	date	08/07/05	date	11/07/05								
time	10:35	time	12:11	time	13:45	time	08:38	time	08:32								

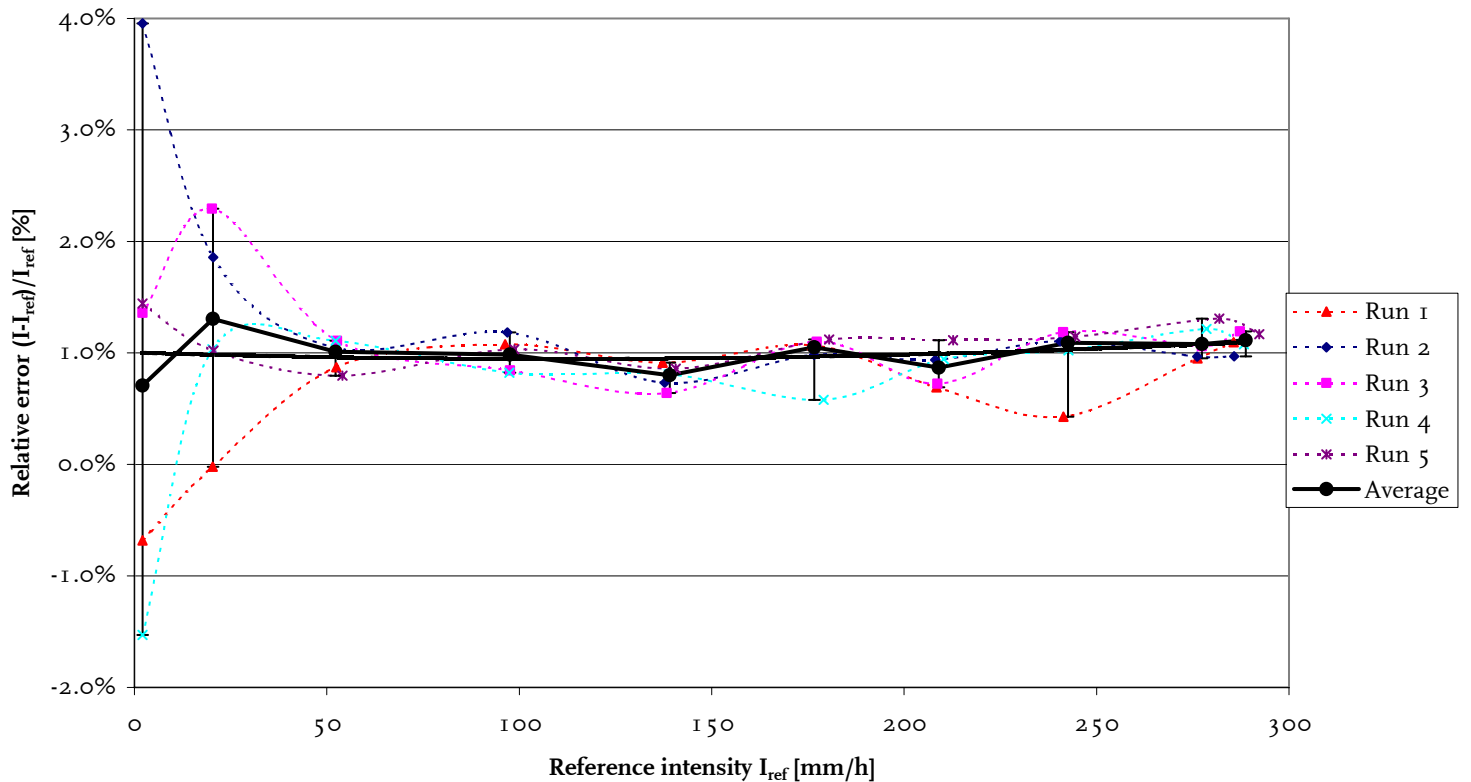

1			2			3			4			5			Intensity	
run	#1		run	#2		run	#3		run	#4		run	#5			
Ser.nr	061-04		Ser.nr	061-04		Ser.nr	061-04		Ser.nr	061-04		Ser.nr	061-04			
Tamb	24.1		Tamb	24.5		Tamb	24.5		Tamb	21.9		Tamb	23.7			
Twater	22.2		Twater	22.5		Twater	22.8		Twater	21.2		Twater	21.8			
RelHum	41.9		RelHum	42.4		RelHum	40.6		RelHum	52.6		RelHum	49.2			
QNH	1011		QNH	1012		QNH	1013		QNH	1005		QNH	1005			
date	05/07/05		date	05/07/05		date	05/07/05		date	06/07/05		date	06/07/05			
time	06:51		time	10:53		time	13:13		time	07:32		time	09:40			
@precip.	measured		@precip.	measured		@precip.	measured		@precip.	measured		@precip.	measured		@precip.	result
mm/h	deviation		mm/h	deviation		mm/h	deviation		mm/h	deviation		mm/h	deviation		mm/h	deviation
2	2.0	-0.6% I	2.0	0.0% I		2.0	0.3% I		2.0	1.0% O		2.0	-2.6% O		2.0	-0.1% I
20	20.6	1.2% O	20.6	0.6% O		20.8	0.8% I		20.7	0.6% I		20.3	0.6% I		20.6	0.7% I
50	53.1	0.5% O	53.1	0.8% I		52.6	1.1% O		52.6	0.7% I		52.8	1.0% I		52.8	0.8% I
90	97.6	0.9% I	98.0	1.1% O		97.3	0.9% I		97.1	0.1% O		97.5	1.0% I		97.5	0.9% I
130	139.2	0.3% O	139.4	0.8% O		138.4	0.5% I		138.5	0.5% I		138.8	0.8% I		138.5	0.6% I
170	177.7	0.7% I	179.1	0.8% O		177.5	0.7% I		177.5	0.6% O		178.1	0.6% I		177.8	0.7% I
200	210.3	0.7% O	211.8	0.4% O		209.3	0.6% I		209.6	0.5% I		210.2	0.7% I		209.7	0.6% I
229	243.6	0.8% I	243.5	1.1% O		242.0	0.7% O		242.0	0.9% I		243.2	1.0% I		242.9	0.9% I
262	280.4	0.8% O	280.1	1.1% I		278.6	1.2% O		278.4	0.9% I		279.9	1.0% I		279.5	1.0% I
270	290.0	0.6% O	291.1	1.1% O		289.4	1.0% I		288.0	0.8% I		289.1	1.0% I		288.8	0.9% I
Tamb	24.3		Tamb	24.4		Tamb	23.8		Tamb	23.5		Tamb	24.2			
Twater	22.5		Twater	22.8		Twater	22.7		Twater	21.3		Twater	22.2			
RelHum	41.3		RelHum	41.3		RelHum	40.9		RelHum	48.9		RelHum	51.0			
QNH	1012		QNH	1013		QNH	1012		QNH	1005		QNH	1005			
date	05/07/05		date	05/07/05		date	05/07/05		date	06/07/05		date	06/07/05			
time	09:46		time	13:06		time	15:42		time	09:04		time	12:14			

