

The logo for HydroMet, featuring a white diagonal slash followed by the text "HydroMet" in a bold, white, sans-serif font.

/ HydroMet

User Manual

DH48

The KISTERS logo, consisting of a white stylized 'K' symbol followed by the word "KISTERS" in a bold, white, sans-serif font. Below the logo is the tagline "Empowering decisions of tomorrow" in a smaller, white, sans-serif font.

KISTERS
Empowering decisions of tomorrow

Table of Contents

I	Disclaimer	3
II	Scope of Delivery	4
III	Safety Instructions	5
Part I	Introduction	6
Part II	Operation	7
2.1	Example	7
2.2	Diagram	9
Part III	Repair	10
3.1	Part List	11
Part IV	Technical Data	12
Part V	Obligations of the Operator and Disposal	13
5.1	Obligations of the Operator	13
5.2	Dismantling / Disposal	13

I Disclaimer

The information provided in this manual was deemed accurate as of the publication date. However, updates to this information may have occurred.

This manual does not include all of the details of design, production, or variation of the equipment nor does it cover every possible situation which may arise during installation, operation or maintenance. KISTERS shall not be liable for any incidental, indirect, special or consequential damages whatsoever arising out of or related to this documentation and the information contained in it, even if KISTERS has been advised of the possibility of such damages.

Any errors found in any KISTERS product should be reported to KISTERS where every effort will be made to quickly resolve the problem.

Copyright Notice: No parts of this work may be reproduced in any form or by any means without the written permission of the publisher. KISTERS waives copyright for users to print out parts of the documentation in hard copy for their own use only.

Trademark Notice: KISTERS products and services referred to in this document are trademarks or registered trademarks of KISTERS. Other product names used may or may not be the trademarks of their respective owners.

© 2023 | KISTERS. Any rights not expressly granted herein are reserved.

II Scope of Delivery

- Set of three nozzles: 3.2, 4.8 and 6.3 mm
- Sampler bottle DH4805 (see below, additional bottles available as spare parts)
- Wading rod
- Canvas carry bag
- Instruction manual available from hyquestsolutions.com

III Safety Instructions

- Read the user manual including all operating instructions prior to installing, connecting and powering up the KISTERS DH48. The manual provides information on how to operate the product. The manual is intended to be used by qualified personnel, i.e. personnel that have been adequately trained, are sufficiently familiar with installation, mounting, wiring, powering up and operation of the product.
- Keep the user manual on hand for later reference!
- If you encounter problems understanding the information in the manual (or part thereof), please consult the manufacturer or its appointed reseller for further support.
- KISTERS DH48 is intended to be used in hydrometeorological or environmental monitoring applications.
- Before starting to work, you have to check the functioning and integrity of the system.
 - Check for visible defects on the DH48, this may or may not include any or all of the following mounting facilities, connectors and connections, mechanical parts, internal or external communication devices, power supplies or power supply lines, etc.
 - If defects are found that jeopardize the operational safety, work must be stopped. This is true for defects found before starting to work as well as for defects found while working.
- Do not use the KISTERS DH48 in areas where there is a danger of explosion.
- The present user manual specifies environmental/climatic operating conditions as well as mechanical and electrical conditions. Installation, wiring, powering up and operating the KISTERS DH48 must strictly comply with these specifications.
- Perform maintenance only when tools or machinery are not in operation.
- If guards are removed to perform maintenance, replace them immediately after servicing.
- Never make any electrical or mechanical diagnostics, inspections or repairs under any circumstances. Return the product to the manufacturer's named repair centre. You can find information on how to return items for repair in the relevant section of the KISTERS website.



- Disposal instructions: After taking the KISTERS DH48 out of service, it must be disposed of in compliance with local waste and environmental regulations. The KISTERS DH48 is never to be disposed in household waste!
-
-  Inputs and outputs of the device are protected against electric discharges and surges (so-called ESD). Do not touch any part of the electronic components! If you need to touch any part, please discharge yourself, i.e. by touching grounded metal parts.

1 Introduction

Thank you for choosing our product. We hope you will enjoy using the device.

KISTERS manufactures, sells, installs and operates quality instrumentation, data loggers and communication technology. Products are designed with passion for environmental monitoring and with a deep understanding of the quality, accuracy and robustness needed to fulfil the requirements of measurement practitioners in the field.

The present User Manual will help you understand, install and deploy the device. If, however, you feel that a particular information is missing, incomplete or confusing, please do not hesitate to contact us for further support!

The lightweight hand sampler DH48 is used for the collection of suspended sediment samples by wading rod suspension.

2 Operation

Round bottles are used for sample containers. Pressure from a spring tensioned operating rod, which is rotated by hand to bear upon the base of the sample bottle, holds and seals the bottle against a rubber gasket within the casting. The contact between the sample bottle and the gasket should be air tight and should be tested by blocking off the air exhaust tube with a finger and blowing into the nozzle each time a bottle is fitted to the sampler. The operating rod assembly can be removed from the recess provided at the rear of the support beam, and the pressure exerted by the operating rod can be adjusted by increasing or decreasing the compression of the operating spring. The axis of the sample container is inclined at an angle to the vertical which permits sampling to within 90 mm of the stream bed. With the instrument oriented into the direction of flow (nozzle horizontal and pointed upstream) a continuous stream filament is discharged into the sample bottle during the period of submergence. The air displaced by the sample is ejected through the air escape passage projecting from the instrument alongside the head and oriented to discharge downstream. A fixed static head differential between the intake and air exhaust, facilitates sampling in low stream velocities and slack waters. Three nozzles, 1/8", 3/16" and 1/4" diameter are supplied with each sampler. One is chosen for each sampling cross section according to the velocity and depth to be sampled.

A clean bottle should be used for each separate sediment sample. At least one suspended sediment sample is taken at each stream vertical selected in the cross section. In a sampling operation, the intake nozzle is oriented upstream, directly into the current, while the sediment sampler is lowered into the stream.

Submerged obstructions directly upstream or adjacent to the sampler should be avoided to preclude interference with the stream filament approaching the intake nozzle. The sampler should be lowered at a uniform rate from the water surface to the bottom of the stream, instantly reverse the direction of the transit, and raise the sampler again to the water surface at a uniform but not necessarily an equal rate. Each filled sample bottle when removed from the instrument should be capped immediately and appropriately marked.

The sampler continues to take its sample in flowing water throughout the time of submergence, even after the bottle is completely filled.

If the bottle becomes entirely full, the sample may not be representative and it should be discarded. Although the capacity of the sample container is about 470 ml, the tilt of the bottle is such that any sample containing more than 440 ml of a water sediment mixture may be in error. In order to provide sufficient sample for a laboratory analysis, the length of time the instrument remains submerged should be adequate to produce a sample volume greater than 375 ml but not to exceed 440 ml. It is generally preferable to save an initial sample smaller than 375 ml but larger than 300 ml than to discard the sample on the spot and re-sample into the same bottle. Moreover if the initial sample volume is considerably less than 300 ml, the stream vertical may be integrated a second time, or even a third time, each being additive to the same sample bottle. A minimum sample of 350 ml is suggested.

Sample Size

The volume of sample collected throughout any stream vertical is dependent primarily upon the mean stream velocity in the vertical, the size of the intake nozzle, and the time of submergence of the instrument. The operator must regulate the size of the sample accumulated by establishing the appropriate time period over which the sample is to be taken. Thus the volume of the sample may be increased or decreased by varying correspondingly the sampling time. The attached graph shows the relation between stream velocity and filling time to produce samples 395 ml in volume for three different nozzle sizes. The filling time in seconds represents the total time of submergence of the instrument and includes the time involved in traversing the stream vertical in both the downward and upward direction.

2.1 Example

(Refer [Diagram 1](#))

Mean Velocity 1.2 metres/sec.

Nozzle 1/4"

Filling Time 10 seconds

If the sampler is lowered from the water surface to the stream bed at a uniform rate in 5 seconds, it should be raised at a uniform rate so as to break the water surface at the expiration of the next 5 seconds. The time of traversing the stream vertical need not be the same in both directions of travel. However, the rate at which the sampler moves vertically must remain uniform in each direction of travel. Thus, in the above example, the stream vertical could have been traversed at a uniform rate downward in 4 seconds and the sampler raised at uniform rate upward to clear the water surface in 6 seconds, the total submergence period still being 10 seconds.

Sample Notations

Adequate information and data to identify the sample and to satisfy the purposes of the investigation should be recorded at the time of sampling. The following items are suggested:

- Name of Gauging Station
- Location of the cross section
- Location of vertical
- Stream depth covered by the sample
- Stage of the stream
- Date
- Time of day
- Identification of personnel
- Sampling time
- Water temperature
- Coordination with sample groups
- Serial number of sample

Before the bottles are reused, they should be washed clean inside and outside to avoid contamination of future samples.

2.2 Diagram

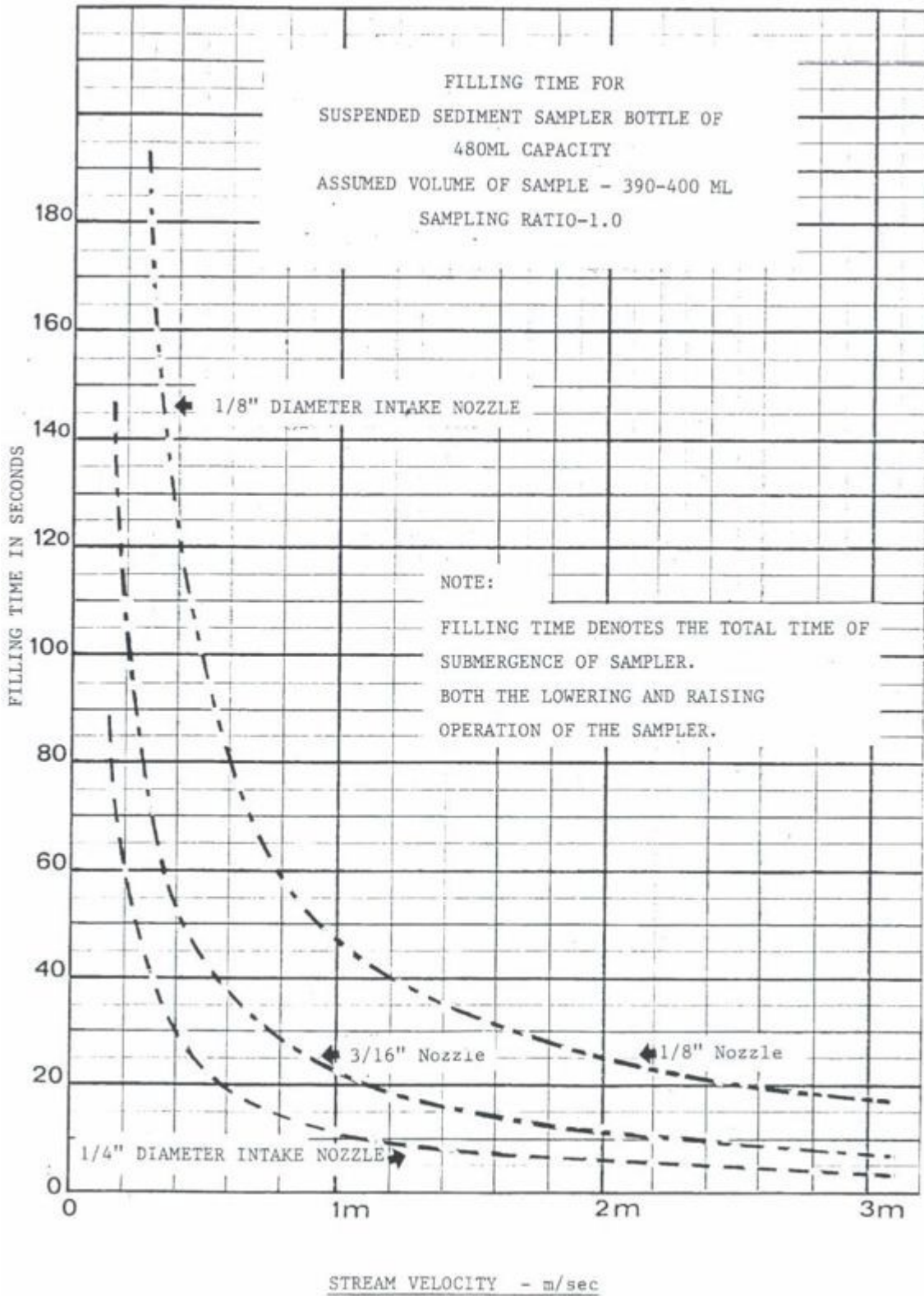

DIAGRAM 1 - FILLING CHART

3 Repair

KISTERS precision instruments and data loggers are produced in quality-controlled processes. All KISTERS production and assembly sites in Australia, New Zealand and Europe are ISO 90001 certified. All equipment is factory tested and/or factory calibrated before it is shipped to the client. This ensures that KISTERS products perform to their fullest capacity when delivered.

Despite KISTERS most rigorous quality assurance (QA), malfunction may occur within or outside of the warranty period. In rare cases, a product may not be delivered in accordance with your order.

In such cases KISTERS' return and repair policy applies. For you as a customer, this means the following:

- Contact KISTERS using the Repair Request Form and the Declaration of Contamination made available online:

Region (Language)	Download Link
Asia-Pacific (English)	Repair Request Form (APAC) Declaration of Contamination (APAC)
Europe, the Middle East and Africa (English)	Repair Request Form (EMEA) Declaration of Contamination (EMEA)
Germany (German)	Repair Request Form (DE) Declaration of Contamination (DE)

In response you will receive a reference number that must be referenced on all further correspondence and on the freight documents accompanying your return shipment.

- Please provide as much information and/or clear instructions within the return paperwork. This will assist our test engineers with their diagnosis.
- Please do not ship the goods prior to obtaining the reference number. KISTERS will not reject any equipment that arrives without reference number; however, it may take us longer to process.

Custom requirements for items sent to KISTERS for warranty or non-warranty repairs: Check with your national customs/tax authorities for details, processes and paperwork regarding tax exempt return of products. Typically, special custom tariff codes are available (such as HS Code = 9802.00) that verify the item is being returned for repair and has no commercial value. Please note that the customs invoice / dispatch documents should also clearly state: "Goods being returned to manufacturer for repair - No Commercial value". It is mandatory to have any returned goods accompanied by a commercial invoice on headed paper. KISTERS reserves the right to charge the customer for time spent rectifying incorrect customs documents.

Note: Please ensure that your goods are packed carefully and securely. Damage that occurs during transit is not covered by our warranty and may be chargeable.

- [Part List](#) 

3.1 Part List

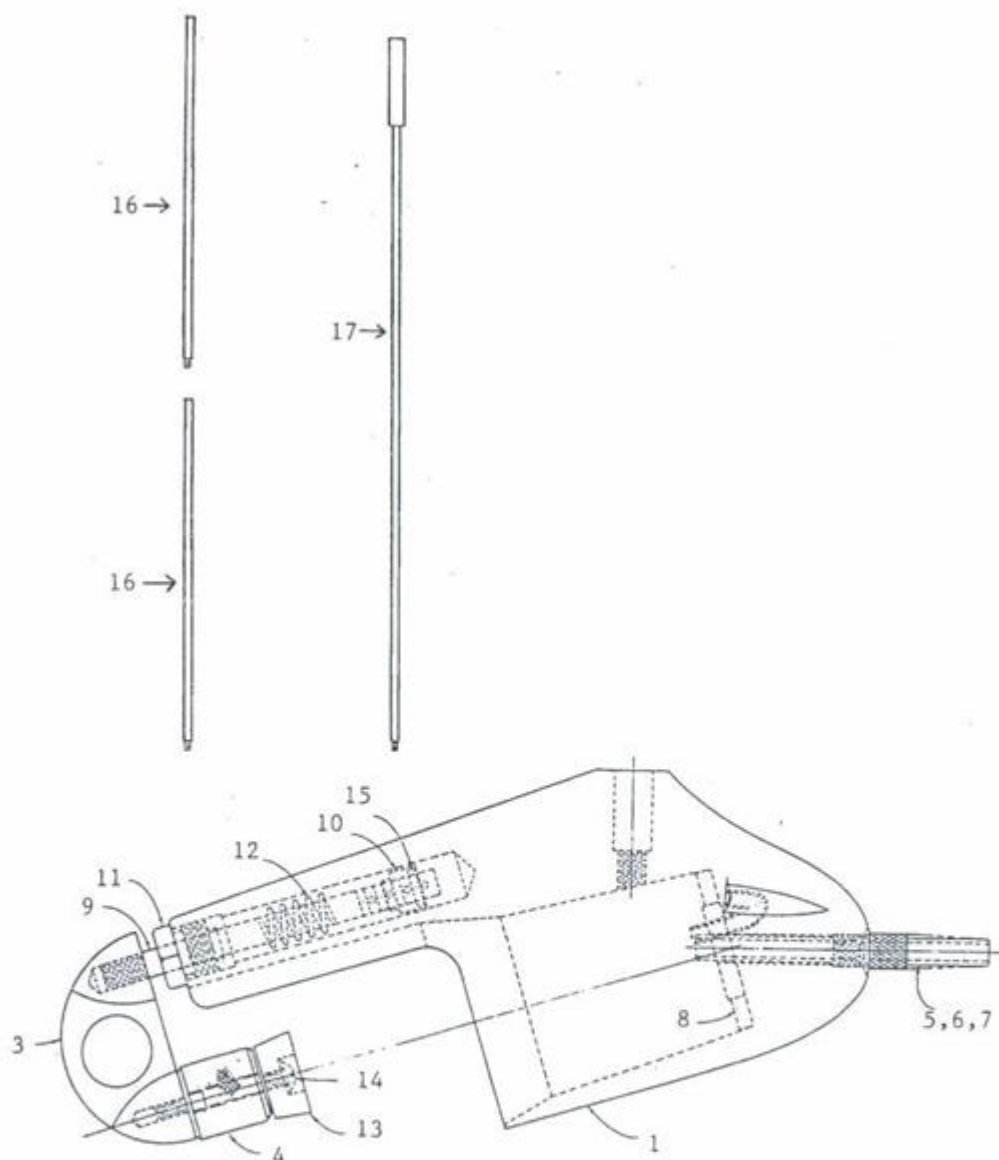

ITEM	DESCRIPTION	PART NO.	ITEM	DESCRIPTION	PART NO.
1	BODY	DH48 01-01	10	ROD GUIDE	DH48 01-10
3	HANDLE	DH48 01-03	11	ROD NUT	DH48 01-11
4	KNURLED SPACER	DH48 01-04	12	SPRING	DH48 01-12
5	NOZZLE 1/8"	DH48 01-05	13	PAD	DH48 01-13
6	NOZZLE 3/16"	DH48 01-06	14	SCREW	SC007-08
7	NOZZLE 1/4"	DH48 01-07	15	ROLL PIN	SC042-16
8	GASKET	DH48 01-08	NOT SHOWN	CANVAS BAG	DH48 02
9	OPERATING ROD	DH48 01-09	16	0.5 M WADING ROD	DH48 04
			17	1.0 M WADING ROD WITH HANDLE	DH48 03

4 Technical Data

Type	Hand held wading sampler
Materials	Cast aluminium
Maximum Depth	1 m from water surface (minimum distance from bed 90 mm)
Wading Rods	1 m (in 2 sections of 0.5 m), 13 mm diameter
Length	330 mm
Net Weight	2 kg (4 lb)
Packing Details	6 kg (13 lb), 0.01 m ³

5 Obligations of the Operator and Disposal

This chapter contains the following subsections:

- [Obligations of the Operator](#) ¹³¹
- [Dismantling / Disposal](#) ¹³¹

5.1 Obligations of the Operator

European Union

In the Single European Market it is the responsibility of the operator to ensure that the following legal regulations are observed and complied with: national implementation of the framework directive (89/391/EEC) and the associated individual directives, in particular 2009/104/EC, on minimum safety and health requirements for the use of work equipment by employees at work.

Worldwide

Regulations: If and where required, operating licences must be obtained by the operator. In addition, national or regional environmental protection requirements must be complied with, regardless of local legal provisions regarding the following topics:

- Occupational safety
- Product disposal

Connections: Local regulations for electrical installation and connections must be observed.

5.2 Dismantling / Disposal

When disposing of the units and their accessories, the applicable local regulations regarding environment, disposal and occupational safety must be observed.

Before dismantling

- Electrical Devices:
 - Switch off the units.
 - Disconnect electrical appliances from the power supply, regardless of whether the appliances are connected to the mains or to another power source.
- Mechanical devices:
 - Fix all loose components. Prevent the device from moving independently or unintentionally.
 - Loosen mechanical fastenings: Please note that appliances can be heavy and that loosening the fastenings may cause them to become mechanically unstable.

Disposal

Operators of old appliances must recycle them separately from unsorted municipal waste. This applies in particular to electrical waste and old electronic equipment.

Electrical waste and electronic equipment must not be disposed of as household waste!

Instead, these old appliances must be collected separately and disposed of via the local collection and return systems.

Integrated or provided batteries and accumulators must be separated from the appliances and disposed of at the designated

collection point. At the end of its service life, the lithium-ion battery must be disposed of according to legal provisions.

EU WEEE Directive





As players in the environmental market, KISTERS AG is committed to supporting efforts to avoid and recycle waste. Please consider:

- Avoidance before recycling!
- Recycling before disposal!



This symbol  indicates that the scrapping of the unit must be carried out in accordance with Directive 2012/19/EU. Please observe the local implementation of the directive and any accompanying or supplementary laws and regulations.

Contact Data

Europe	KISTERS Europe	 +49 2408 9385 0
		 hydromet.sales@kisters.eu
		 www.kisters.eu
Australia	KISTERS Australia	 +612 9601 2022
		 sales@kisters.com.au
		 www.kisters.com.au
New Zealand	KISTERS New Zealand	 +64 7 857 0810
		 sales@kisters.co.nz
		 www.kisters.co.nz
Latin America	KISTERS Latin America	 +57 350 575 4079
		 sales@kisters-latam.com
		 www.kisters-latam.com
North America	KISTERS North America	 +1 561 459 4876
		 kna@kisters.net
		 www.kisters.net
Spain	KISTERS Ibérica	 info@kisters.es
		 www.kisters.es

