

The logo for HydroMet, featuring a white diagonal slash followed by the text "HydroMet" in a bold, white, sans-serif font.

/ HydroMet

User Manual

PVD200

The KISTERS logo, consisting of a white stylized 'K' symbol followed by the word "KISTERS" in a bold, white, sans-serif font. Below the logo is the tagline "Empowering decisions of tomorrow" in a smaller, white, sans-serif font.

KISTERS
Empowering decisions of tomorrow

Table of Contents

I	Disclaimer	3
II	Safety Instructions	4
Part I	Scope of Delivery	5
Part II	Introduction	6
Part III	Installation	8
Part IV	Configuration	9
4.1	Current Meter Counter Menus	9
Part V	Operation	12
5.1	Navigating Screens	12
5.2	Current Meter Counter Operation	13
5.3	Indicator LEDs	14
5.4	Bluetooth® Communications	14
5.4.1	Serial Communications Interface	15
5.4.2	Data Conversion Example	17
5.4.3	Operating the Special Functions Using Serial Communications	18
Part VI	Maintenance	19
6.1	Changing the Batteries	19
Part VII	Troubleshooting	20
Part VIII	Repair	21
Part IX	Technical Data	22
Part X	Obligations of the Operator and Disposal	23
10.1	Obligations of the Operator	23
10.2	Dismantling / Disposal	23
Part XI	Appendices	25
11.1	Capturing a Spin Test	25
11.2	Measuring Meter Dwell	28
11.3	Serial Port Echo Command	29
11.4	Example Calibration Certificate	30
11.5	Ground Feeler Device Model GFD	31

I Disclaimer

The information provided in this manual was deemed accurate as of the publication date. However, updates to this information may have occurred.

This manual does not include all of the details of design, production, or variation of the equipment nor does it cover every possible situation which may arise during installation, operation or maintenance. KISTERS shall not be liable for any incidental, indirect, special or consequential damages whatsoever arising out of or related to this documentation and the information contained in it, even if KISTERS has been advised of the possibility of such damages.

Any errors found in any KISTERS product should be reported to KISTERS where every effort will be made to quickly resolve the problem.

Copyright Notice: No parts of this work may be reproduced in any form or by any means without the written permission of the publisher. KISTERS waives copyright for users to print out parts of the documentation in hard copy for their own use only.

Trademark Notice: KISTERS products and services referred to in this document are trademarks or registered trademarks of KISTERS. Other product names used may or may not be the trademarks of their respective owners.

© 2025 | KISTERS. Any rights not expressly granted herein are reserved.

This document is public.

II Safety Instructions

- Read the user manual including all operating instructions prior to installing, connecting and powering up the KISTERS PVD200. The manual provides information on how to operate the product. The manual is intended to be used by qualified personnel, i.e. personnel that have been adequately trained, are sufficiently familiar with installation, mounting, wiring, powering up and operation of the product.
- Keep the user manual on hand for later reference!
- If you encounter problems understanding the information in the manual (or part thereof), please consult the manufacturer or its appointed reseller for further support.
- KISTERS PVD200 is intended to be used in hydrometeorological or environmental monitoring applications.
- Before starting to work, you have to check the functioning and integrity of the system.
 - Check for visible defects on the PVD200, this may or may not include any or all of the following mounting facilities, connectors and connections, mechanical parts, internal or external communication devices, power supplies or power supply lines, etc.
 - If defects are found that jeopardize the operational safety, work must be stopped. This is true for defects found before starting to work as well as for defects found while working.
- Do not use the KISTERS PVD200 in areas where there is a danger of explosion.
- The present user manual specifies environmental/climatic operating conditions as well as mechanical and electrical conditions. Installation, wiring, powering up and operating the KISTERS PVD200 must strictly comply with these specifications.
- Perform maintenance only when tools or machinery are not in operation.
- If guards are removed to perform maintenance, replace them immediately after servicing.
- Never make any electrical or mechanical diagnostics, inspections or repairs under any circumstances. Return the product to the manufacturer's named repair centre. You can find information on how to return items for repair in the relevant section of the KISTERS website.



Disposal instructions: After taking the KISTERS PVD200 out of service, it must be disposed of in compliance with local waste and environmental regulations. The KISTERS PVD200 is never to be disposed in household waste!



Inputs and outputs of the device are protected against electric discharges and surges (so-called ESD). Do not touch any part of the electronic components! If you need to touch any part, please discharge yourself, i.e. by touching grounded metal parts.

1 Scope of Delivery

Includes:

- The counter unit housed in a polymer enclosure featuring an LCD screen, control buttons and banana sockets.
- A neck strap for the counter unit.

2 Introduction

Thank you for choosing our product. We hope you will enjoy using the device.

KISTERS manufactures, sells, installs and operates quality instrumentation, data loggers and communication technology. Products are designed with passion for environmental monitoring and with a deep understanding of the quality, accuracy and robustness needed to fulfil the requirements of measurement practitioners in the field.

The present User Manual will help you understand, install and deploy the device. If, however, you feel that a particular information is missing, incomplete or confusing, please do not hesitate to contact us for further support!



KISTERS' Point Velocity Display PVD200 is a small electronic device for measuring flow velocity from almost any mechanically rotating current meter. It shows the velocity on its LCD directly in m/sec or ft/sec. PVD200 detects signal shorts automatically and alerts the operator who may decide on repeating the measurement. The device supports up to six current meters, each with three equations.

This measures flow velocity from almost any mechanically rotating current meter. A feature of the device is its ability to "clean" the current meter signal and interface via Bluetooth to a compatible PDA, PocketPC, or other computing device (compatible software also required) and provide serial data that can be used by the external device to compute discharge. Current Meters fitted with a cat whisker ball and wire contact to perform a mechanical switch closure can be used with the unit to produce a clean, noise-free signal. The water velocity is directly computed and displayed on the LCD. The **PVD200** supports up to 6 current meters with each meter having up to 3 rating equations and 3 rotations/sec ranges.

The **PVD200** operates with 3 x AA alkaline 1.5V batteries and comes in a robust waterproof enclosure. The commands are identical to the CMCsp commands, so existing third party compatible software that has been developed, can be used to perform a measurement and make operating selections. The PVD200 can operate with current meter velocities from less than 0.05 ft/sec to more than 20 ft/sec for a Price AA meter. The **PVD200** also provides a slow-speed mode to improve measurements with extremely slow rotating current meters [velocities less than 0.25 ft/sec]. The **PVD200** does not need to be connected to an external device to operate. The visual indicators, LCD and internal buzzer of the **PVD200** can be used to make a conventional current meter measurement and compute water velocity using look up tables if required.

As you continue to read this manual, many features and operating capabilities of the **PVD200** will be revealed and described. The **PVD200** is extremely easy to use and yet versatile enough to offer selections to operate in a wide variety of scenarios and field settings.

As an added benefit, whenever the **PVD200** is inactive, it will automatically turn itself OFF after a preselected period to help conserve the batteries. To turn it ON, simply press the 2 buttons together and all previous settings are restored ready for the user to begin a measurement.

The **PVD200** also has an internal serial port that can be used to upgrade the firmware as new features become available.

Product Overview

Any pulse type current meter can be connected to the **PVD200**, and after entering the pulse to velocity equations, it can display the measured velocity directly. Velocity can be either displayed in feet/sec (ft/sec) or metres/second (m/sec) and is chosen by the user in a menu. When a measurement is being made, the **PVD200** counts contact closures, measures elapsed time, and computes velocity to a precision of 0.01 ft/sec or 0.001 m/sec. The velocity is computed based on the selection from up to 6 entered meter ratings, again chosen from a menu. During a measurement, the **PVD200** sends through the Bluetooth serial port the number of accumulating meter contact closures and elapsed time at 1-second intervals.

An important operating feature of the **PVD200** is the ability to signal process each contact closure. Contact closures from any type of meter are inherently noisy causing miscounting or double counting. The **PVD200** samples the input signal from the connected meter and examines the signal to determine if a contact closure has occurred and if successive signals are of the same characteristics. The **PVD200** then determines contact closure conditions and either counts the signal closure or eliminates the condition as a noise pulse and does not count the signal. For cat's whisker contacts, this becomes extremely important since cat's whisker contacts offer the poorest quality for marking and counting rotations. The options for the internal sounder allow it to operate momentarily or continuously when the current meter contacts close - the continuous mode is ideal for operation with a Ground Feeler Device GFD allowing detection of the river bed - see [Appendix Ground Feeler Device Model GFD](#) ³¹.

The **PVD200** offers (2) modes of operation for a cat whisker type meter - FAST and SLOW speed mode. FAST is selected for meter rotations >0.25 ft/sec while SLOW mode is for velocities below 0.25ft/sec. To improve noise rejection, the sample rate of the input signal at the SLOW speed mode (lower velocities) is 1/10 of the sampling rate that occurs during FAST mode. This slower sampling rate improves performance for back rotations and corroded whisker contacts at extremely low meter cup rotations. It is important to know that the **PVD200** offers operational overlap at this 0.25 ft/sec velocity selection in either mode and therefore it is not necessary for the operator to know precisely the velocity of water for selecting either mode.

3 Installation

Hardware Connections

The current meter is connected through the two banana type sockets at the top of the **PVD200**.



4 Configuration

This chapter contains the following subsections:

- [Current Meter Counter Menus](#)

4.1 Current Meter Counter Menus

While in the Current Meter Counter (CMC) display press and hold the right hand button to enter the CMC Menu's. Pressing "Up/Dn" (left hand button) will move the triangle pointer down through the menus, and pressing "Select" (right hand button) will toggle the option, or select the item.

1. The "Meter" type can be Mag Head, Cat Whisker Fast, or Cat's Whisker Slow.

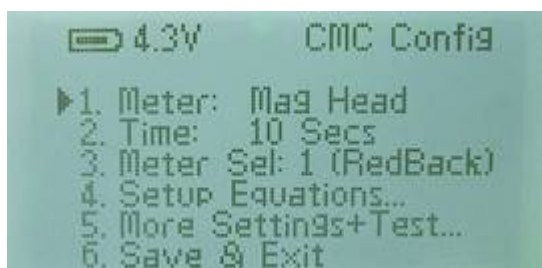

In Mag Head mode the Status LED is Green.

In Cat Whisker Fast the Status LED is Red.

In Cat Whisker Slow the Status LED is off.

One important operating features of the **PVD200** is the ability to signal process each contact closure. Contact closures from any type of meter are inherently noisy causing miscounting or double counting. The **PVD200** samples the input signal from the connected meter and examines the signal to determine if a contact closure has occurred and if successive signals are of the same characteristics. The **PVD200** then determines contact closure conditions and either counts the signal closure or eliminates the condition as a noise pulse and does not count the signal. For Cat's Whisker contacts, this becomes extremely important since Cat's Whisker contacts offer the poorest quality for marking and counting rotations.

In Cat's Whisker mode there are 2 speed settings. **FAST** is selected for meter rotations >0.25 ft/sec while **SLOW** mode is for velocities below 0.25ft/sec. To improve noise rejection, the sample rate of the input signal at the **SLOW** speed mode (lower velocities) is 1/10 of the sampling rate that occurs during **FAST** mode. This slower sampling rate improves performance for back rotations and corroded whisker contacts at extremely low meter cup rotations. It is important to know that the **PVD200** offers operational overlap at this 0.25 ft/sec velocity selection in either mode and therefore it is not necessary for the operator to know precisely the velocity of water for selecting either mode. When in **SLOW** mode, the status LED flickers, and the sounder beeps longer whenever the whisker contacts are made.

2. The "Time" is the CMC elapsed time and can be set to 10, 20, 30, 40,90 Secs
3. Up to 6 different Meters can be selected - the Meters and their equations are entered in the Setup Equations... option.
4. When Setup Equations... is selected, the Meter name and the respective equations are displayed.

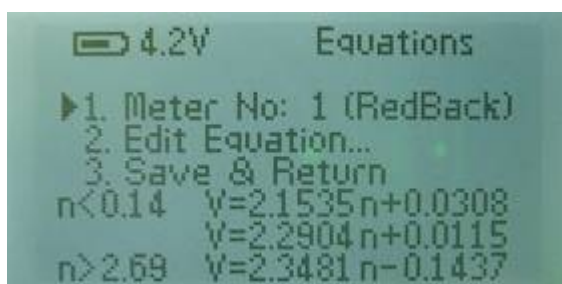

When the triangle is at item 1, and "Select" is pressed, the Meter No is stepped through. The equations for the selected meter are displayed at the bottom of the screen.

5. To Edit a selected Meter Equation, step to item 2 and press "Select".

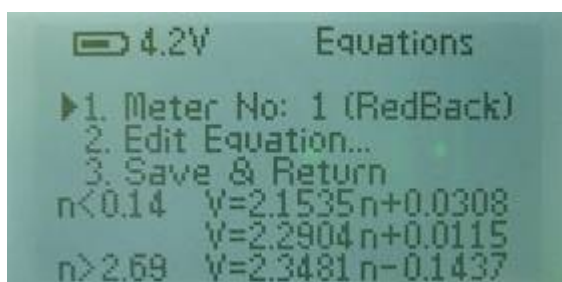

The Meter Serial No (or name), the number of equations (1, 2 or 3), and the equations themselves will be displayed. The first character of the Serial No will be flashing. Press “Up/Dn” (left hand button) to change the character, and press “Select” (right hand button) to select this character and move to the next character. Repeat these steps so the equations on the screen match the equations on your Current Meter calibrations sheets.

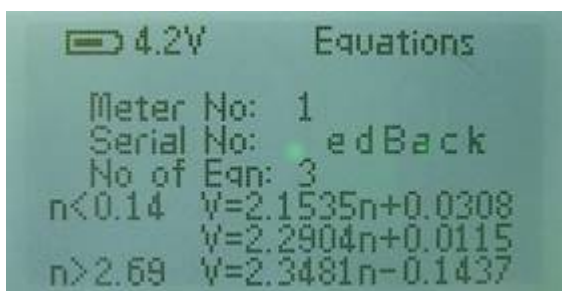

Please Note:

- If a metric result is required you must use m/s equations.
 - If an imperial result is required you must use ft/s equations.
6. Select “Save and Return” to go back to the previous menu.

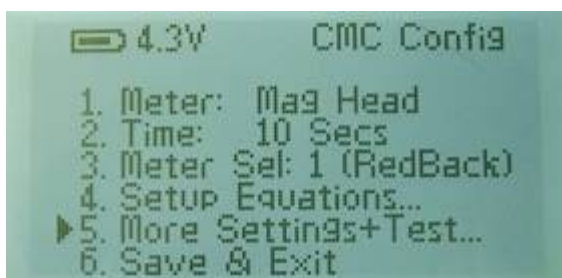

7. When More Settings + Test is selected, 5 more selections become available.

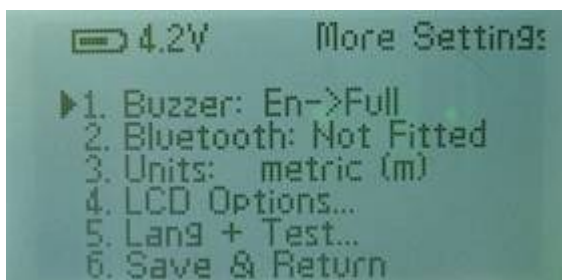

8. The Buzzer can be set to Disable, En→Full, and En→Mom. (When set to En→Full, the buzzer beeps while the contacts are detected as closed) When set to En→Mom, the buzzer beeps only momentarily as the contacts close)
9. If the Bluetooth module is not detected, it will display **NOT FITTED**, otherwise it can be set to Disable, En→CMC or En→Full. At this time both these options provide the same set of Bluetooth commands – a new set of commands will be available for En→Full in the future.
10. The Units selection can be imperial (ft) or metric (m). (The units do not modify the result of the velocity equations – you must enter the appropriate equations to match the required units.)

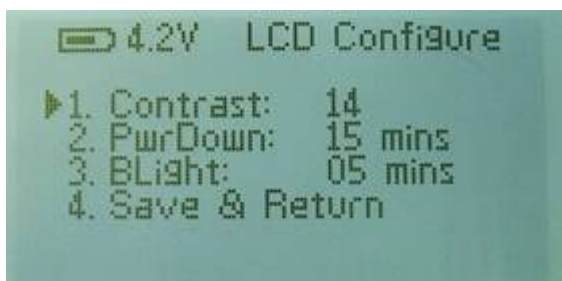

11. LCD Options allows 3 more LCD selections to be chosen.
The contrast can vary between 6 (light) and 24 (dark) and may only need changing at the extremes of ambient temperature.
The Power Down time can be set to 15, 20, 25, 30, 35,.....60 mins. If no buttons are pressed, the **PVD200** will power down automatically after this time.
The BackLight time can be set to 1,2,3,4,5,6...14,15 mins or Off. This is the time the backlight stays on after a button is pressed – when operating in daylight, it is best to set the BackLight Off as this will conserve power and the batteries will achieve considerably longer life.

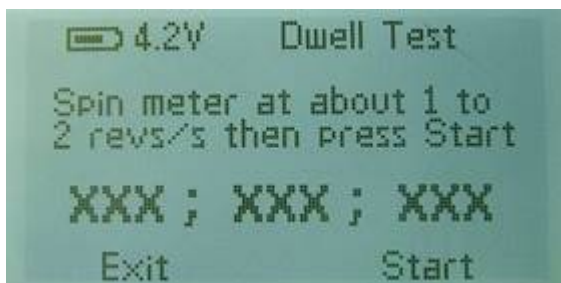
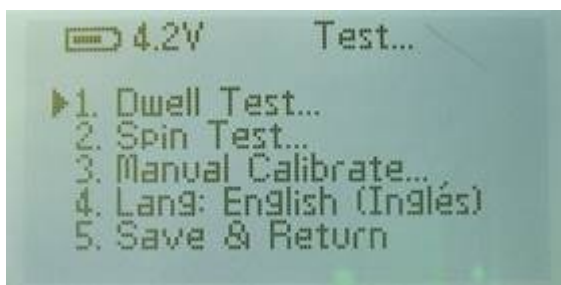

12. The Dwell Test measures the rotational angle that the contact is closed on the Meter head. Spin the meter by hand at about 1 to 2 revs per second and press “Start”. The bottom of the display will show **RDY** while it is waiting for a contact closure, and the Start button function will change to “Stop”. When the 3 angles are measured, the display will **INDICATE** “Done” and the angles will appear across the screen. This function measures the dwell angle (ratio of meter contact time to the total time for a single rotation) for a meter contact and is useful for making adjustments to a cat whisker type meter in the field. For a cat whisker contact head, the optimum adjustment is 60° or a single meter cup width (US Geological Survey Price AA or Pygmy meter). A variation to an adjustment of $\pm 10\%$ is acceptable. The measure of dwell angle for the magnetic head contact does not apply but can be performed.



13. The “Spin Test” is an elapsed time measurement from the time a meter is spun to when rotation of the meter stops. Press “Start” and the display will indicate **RDY**, then the first contact closure will start the time and subsequent closures will increment the count. This will continue until no closures are detected for 10 a second period - indicating the meter has stopped. Note that the time will then jump back 10 secs as the display shows the total count and the elapsed time up to the last count. Press “Stop” if you wish to terminate the test earlier.
14. The “Manual Calibrate” menu allows the analog ac Level and dc Threshold to be measured and displayed. (Everytime the display changes from the TSR menu to the CMC menu, a calibrate is automatically performed - as indicated by the Status LED flashing green and red.) This calibrate process allows the circuitry to take into account the water salinity when measuring the contact closures from the meter. This menu is for testing only.

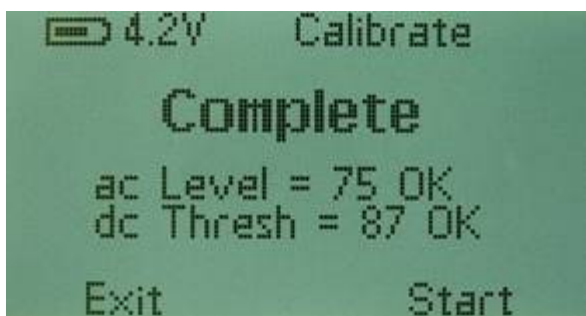

dc Thresh = 87 (fresh water or air)
dc Thresh = 26 (extremely salty water)

5 Operation

This chapter contains the following subsections:



- [Navigating Screens](#) ¹²
- [Current Meter Counter Operation](#) ¹³
- [Indicator LEDs](#) ¹⁴
- [Bluetooth® Communications](#) ¹⁴

5.1 Navigating Screens

The **PVD200** has two front panel buttons that are used to turn power ON and OFF, view menus, and choose operating settings. The labeling on the **PVD200** gives you a reminder of the button functions:

Power ON - Press and hold both buttons to turn on the PVD200.

Power OFF - Press and hold both buttons again to turn off the PVD200. (The off function only occurs when the main screen is displayed)

			
Stop Up/Dn	-CMC- -Menu-	Start Select	
Hold→TSR/CMC		Hold→Menu	



Current Meter Counter
(CMC) Display

 Press and HOLD
Right Button to
 select the CMC
 menus



CMC Menus

5.2 Current Meter Counter Operation

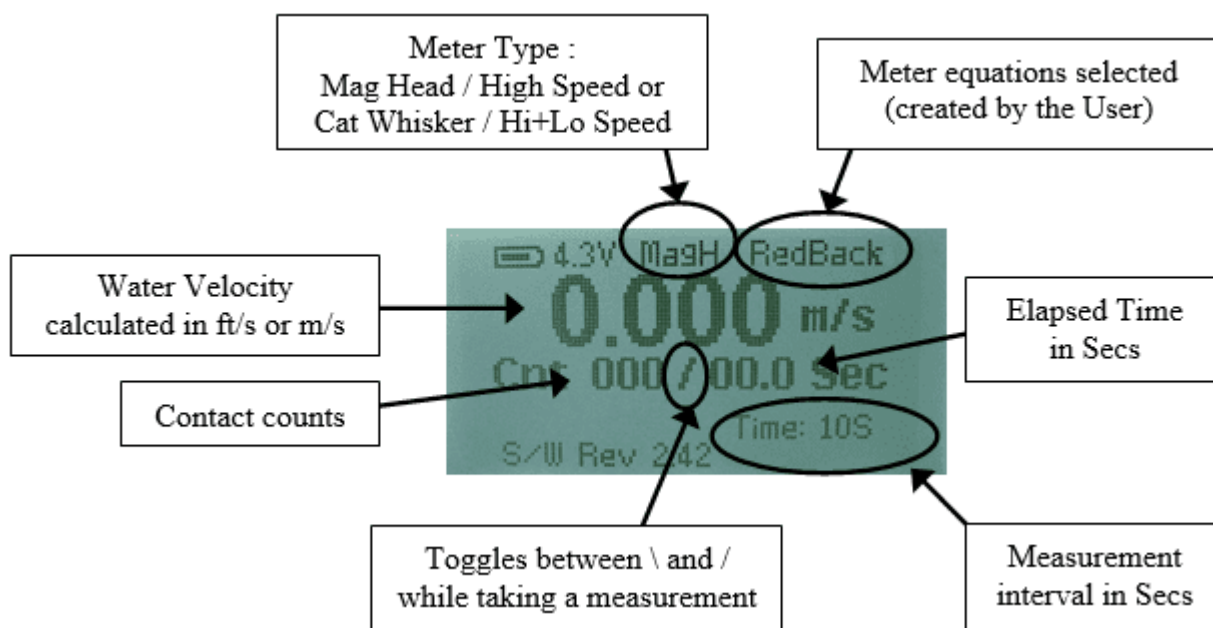

The Current Meter screen data is presented as shown above.

<p>1. Press "Start" (right hand button) and the count, elapsed time and velocity will be zero'd. The / will start toggling between / and \.</p>	
<p>2. When the first meter pulse is detected, the elapsed timer will start. The count and velocity will also be updated as pulses are detected.</p>	

<p>3. When the elapsed timer exceeds the measurement interval, and a meter pulse is detected, the timer will be stopped. The final count, elapsed time and the calculated velocity are all displayed.</p>	
<p>4. If "Stop" (left hand button) is pressed during a measurement, the count, elapsed time and velocity are frozen at that point.</p>	

5.3 Indicator LEDs

The **PVD200** provides two LED indicators to show the unit is operating and to indicate current meter contact closures. The following is a brief description for each indicator.

COUNT (Orange LED)–This indicator will flash whenever a contact closure from the meter has been detected.

OPERATING STATUS (Green/Red/Blue LED)–This indicator remains illuminated whenever the **PVD200** is turned On and showing the operating status mode. The LED has three colors showing the type of meter (Magnetic Head or Cat's Whisker Head) selected as well as Bluetooth® operational status. Green indicates the Magnetic Head is selected and red indicates the Cat's Whisker Head Fast is selected. The indicator also shows the operating mode.

The indicator will flash Blue while searching for a Bluetooth connection, and be Blue steady when a connection is established.

5.4 Bluetooth® Communications

Bluetooth® provides for a wireless link to an external device such as a PocketPC (PDA) or laptop. **Bluetooth®** is a wireless standard (IEEE 802.14) that offers a transparent serial port protocol for communication. When the **PVD200** is turned On, the **PVD200** determines if **Bluetooth®** is installed. If available, **Bluetooth®** can be enabled and 'discovered' by another **Bluetooth®** device to establish a connection. Set the external device's communication protocol in the following manner:

Baud Rate:	19200
Data bits:	8
Stop bits:	1
Parity:	None
Flow control:	None

When this display is presented, the STATUS indicator will be blue and flashing. When another **Bluetooth®** compatible device is in proximity of the **PVD200**, and the device's application requests a connection, each automatically establishes the **Bluetooth®** serial interface protocol. When the connection has been established, the STATUS indicator will show a solid blue color continuously.

When making a connection with another **Bluetooth®** device for the first time, first examine and prepare the required enabling features of the external device for **Bluetooth®** connection. Enable the **PVD200 Bluetooth®** function and allow the external device to 'discover' the **PVD200**. When the external device makes 'discovery', the user must select the **PVD200** within the device's menu setup and enable the connection. The external device should respond with a 'connected' message. The **PVD200** can now be used in a normal manner. All serial data sent from the **PVD200** will be transmitted via **Bluetooth®**. The connection

can be disengaged by selection in the 'Bluetooth' menu. The operator must monitor the integrity of the connection from the external device. If the connection becomes broken, the **PVD200** will revert back to **Bluetooth®** DISCOVER mode. The blue flashing LED will alert the operator of a disconnection between the **PVD200** and the external device. Connection will have to be rediscovered by the external device. Any active measurement occurring during a broken communications link will terminate and the measurement will need to be retaken. The **PVD200** will not automatically power down when **Bluetooth®** is enabled and connected.

For more information, see the following subsections:

- [Serial Communications Interface](#) ¹⁵
- [Data Conversion Example](#) ¹⁷
- [Operating the Special Functions Using Serial Communications](#) ¹⁸

5.4.1 Serial Communications Interface

The **PVD200** can be connected to a hand-held or notebook computer or any device that can transmit and receive serial communications using **Bluetooth®** using an application such as HyperTerm. Commands can be sent to the **PVD200** to perform special functions or select operating modes. The following describes the serial data requirements, commands, and data formats that are used for the serial communications interface:

Baud Rate:	19,200
Format:	8 data bits, no parity, 1 stop bit
Flow Control:	None

The following list shows the commands and functions that can be performed through the serial communications interface.

Command	Function Performed
S	Start a measurement
T	Terminate the measurement
I	Abort the measurement
R	Resend the last data string (** not implemented yet **)
U	Buzzer ON
Z	Buzzer OFF
H	Cat Whisker Speed Select, set to Fast
L	Cat Whisker Speed Select, set to Slow
M	Select Magnetic Head meter processing
C	Select Cat Whisker Head meter processing (Fast)
P	Start a measurement without performing a calibration
Q	Start a measurement with no time limit (continuous measure)
V	Software Version

Note: Commands sent to the **PVD200** are case sensitive – and must be upper case only.

When the commands '**S**', '**T**', and '**I**' are received by the **PVD200** from an externally connected device, the **PVD200** sends an acknowledge character '**A**' back to the device. For the '**S**' command, the **PVD200** sends acknowledge character '**A**' after the **PVD200** performs and completes the calibration. **Note** that invalid or unrecognized commands will result in a '?' being transmitted through the Bluetooth port.

S	<p>Start a measurement: Begins a measurement at the first contact closure detected. Number of contact closures and elapsed time counts are accumulated. At the first contact closure, the PVD200 begins sending the accumulated contact closures and elapsed time counts through the serial port every second. The first data string transmitted through the serial port begins the start of the measurement interval with the meter contact closure count tally and elapsed time tally of '0'. Note that when this command is received by the PVD200, it automatically performs a calibration then monitors the input for meter contact closures. Following is the output data format sent to the externally connected device at the 1-second output rate:</p> <p>dnn,xxxx_</p> <p>d = preamble for indicating display data</p> <p>nn = number of meter contact closures, transmitted in HEX ASCII (hexadecimal notation)(i.e. 0-9,A-F)</p> <p>, = delimiter</p> <p>xxxx = counts of elapsed time measured as 0.003333 seconds/count, transmitted in HEX ASCII (i.e. 0-9,A-F) while in Normal mode and 0.03333 seconds/count while in Slow mode.</p> <p>_ = space</p> <p>This data format that is transmitted to the externally connected device can be used to display elapsed time and velocity while the measurement is being performed.</p> <p>At the end of the measurement interval or if the 'T' command is received, the PVD200 sends the last tally of accumulated counts and time in the following format:</p> <p>fnn,xxxx or enn,xxxx</p> <p>f = final data, no detected faults</p> <p>e = final data, error detected during measurement; restart the measurement</p> <p>The measuring interval is based on the user selected measurement time. When the measuring interval has been reached, (or the T command is received) the PVD200, upon the next meter contact closure, will send the final data for that measurement. If there is no contact closure detected when the measurement interval has been reached, the PVD200 will continue to send data and the user must send the 'I' command to abort the function. Note that the meter contact number, nn, is limited to a total of 255 counts (hexadecimal notation 'FF'). If more than 255 counts are detected throughout the measurement interval, the count will rollover to '00' and continue to accumulate counts. No fault condition is set if this occurs. This allows for continuous counting in excess of 255 counts occurring during the measuring interval. External processing software can easily detect this condition and process total meter counts when the measuring interval is completed. The same condition occurs for the elapsed time tally. This permits an elapsed time count of 218 seconds for a measuring interval before the count rolls over to '0000'.</p>
T	<p>Terminate the measurement: PVD200 stops the measurement at the next contact closure and, at the next contact closure (which is counted), sends the last tally of accumulated counts and elapsed time as previously described.</p>
I	<p>Abort the measurement: The PVD200 aborts the measurement. No final measurement data is transmitted.</p>
P	<p>Start a measurement without doing a calibration: This command is used to begin a measurement without performing a calibration. The command should only be used for a high velocity measurement that does not allow a calibration to be performed due to the rapid rotation of the meter cups.</p>

Q	Continuous measurement: This command is used to continuously output a 1-second data display without a time limit. The T or I command must be used to terminate the operation.
V	The software version of the PVD200 is sent in the following manner: vX.X Example: v1.0

5.4.2 Data Conversion Example

The data format of the **PVD200** is transmitted in HEX ASCII (base 16 numbers using the ASCII code which is displayable on any terminal) to provide efficiency in the number of data characters sent through the serial interface. Following is an example of the interpretation of the data.

Example: d0C,0AF6

Accumulated meter counts = $0C_{16} = 12_{10}$

Elapsed time = $0AF6_{16} = 2806_{10} = (2806 \text{ counts} \times 0.003333 \text{ sec/count}) = 9.35 \text{ secs}$.

The data format says a total of 12 meter counts have been accumulated in 9.35 seconds.

Shown below is a simple Excel program that easily converts hexadecimal numbers to decimal (base 10) numbers. The column 'Decimal Conversion' shows the Excel formula.

	A	B
0	Hexadecimal	Decimal
1	Number	Conversion
2		
3	1F	=hex2dec(A3)

Data Format Notes

The data format presented by the **PVD200** during a measurement provides for displaying a computed velocity by an external device at a 1-second rate. The accumulating contact closure counts and time interval counts can be used in a rating equation to display velocity. At the end of the measuring interval, a final total of contact closures and interval time is then used to compute the measured velocity. For the Normal mode, the 1-second output data format displays the accumulating time interval counts based on a 300 Hz sample rate. The following example below shows how it would be presented using the 'HyperTerminal' program: **NORMAL** mode, 300 Hz sample rate, counts accumulating at a 1 Hz rate.

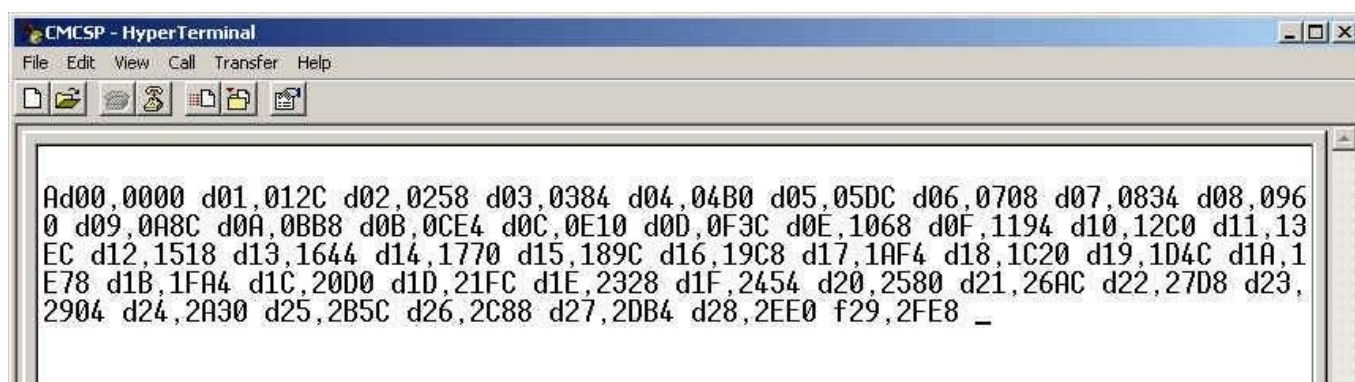

For **SLOW SPEED** mode operation, the display of the accumulating time interval counts differs in that the value is based on a 30 Hz sample rate. The following example below shows how it would be presented in the **SLOW SPEED** mode:

30 Hz sample rate, counts accumulating at a 0.25 Hz rate (1 count every 4 seconds)

```

Ad00,0000 d00,001E d00,003C d00,005A d01,0078 d01,0096 d01,00B4 d01,00D2 d02,00F0
d02,010E d02,012C d02,014A d03,0168 d03,0186 d03,01A4 d03,01C2 d04,01E0 d04,01FE
d04,021C d04,023A d05,0258 d05,0276 d05,0294 d05,02B2 d06,02D0 d06,02EE d06,030C
d06,032A d07,0348 d07,0366 d07,0384 d07,03A2 d08,03C0 d08,03DE d08,03FC d08,041A
d09,0438 d09,0456 d09,0474 d09,0492 d0A,04B0 d0A,04CE d0A,04EC d0A,050A f0B,0524

```

5.4.3 Operating the Special Functions Using Serial Communications

The special function 'SPIN Test' can be operated using the serial communications interface. A laptop, desktop PC, or PocketPC using a terminal emulating package or Microsoft®'s HyperTerminal can be used to invoke the function. No menu selections in the **PVD200** are needed. The selection of the meter type and turning the buzzer On and Off can all be done using the serial communications interface. These functions can also operate using **Bluetooth®**.

The following list shows the commands and functions that can be performed through the serial communications interface.

Command	Function Performed
N	Spin Test
S	Start Spin Measurement (subcommand in 'Spin Test')
A	Stop Spin Measurement (subcommand in 'Spin Test')
U	Buzzer ON
Z	Buzzer OFF
M	Magnetic Head Meter
C	Cat Whisker Head Meter
I	Abort function

When the 'N' command is received by the PVD200 from an externally connected device, the **PVD200** echoes acknowledge character 'N' back to the device.

Refer to [Appendix Capturing a Spin Test](#) for details in using the Spin Test and capturing a 'spin test file'.

6 Maintenance

There is no specific maintenance for the **PVD200**. As with any electronic device, care must be taken to insure minimal exposure to moisture, dirt, or other contaminants. The unit is splash proof; however, it is not waterproof. If the unit becomes submerged in water, remove the batteries and any remaining water. Allow the unit to dry out completely before reinstalling the batteries.

There are no user serviceable parts inside the **PVD200**. If the unit does not function properly, the unit must be returned to KISTERS for component repair.

The **PVD200** does not require any calibration or adjustments. The **PVD200** is self-calibrating and will perform this operation whenever the unit is turned on and whenever "Manual Calibrate" is selected via the menu, or whenever a start measurement command ('S') is received through the serial communications interface.

For more information, see the following subsection:

- [Changing the Batteries](#)

6.1 Changing the Batteries

Note: For optimum performance, the batteries should always be replaced with three good quality AA alkaline 1.5 V batteries!!

Simply lift the clip at the bottom of the front face, and lift the front cover upwards.

Insert the new batteries taking care of the battery orientation - which is stamped on the bottom of the battery enclosure.

Please Note: Installing the batteries backwards will not damage the **PVD200**.

7 Troubleshooting

Device does not power on:

- Check the battery status: Ensure the batteries are correctly installed and charged.
- Inspect the power connections. Look for loose or corroded terminals.

LCD screen not displaying properly:

- Dim or blank screen:
 - Check the battery voltage.
- Frozen display:
 - Remove and reinsert the batteries.

No response from buttons:

- Check for any physical damage or debris around the buttons.
- Low power: Check the battery voltage.
- Firmware issue: Consider updating or reinstalling the firmware.

Incorrect or no count registered:

- Verify the sensor connection.
 - Ensure the banana sockets are properly connected to the current meter.
 - Inspect the cable for any signs of damage. Look for frayed or broken wires. Use a multimeter to check the cable's integrity.
- Check for signal interference. Avoid placing it near strong electromagnetic sources.

8 Repair

KISTERS precision instruments and data loggers are produced in quality-controlled processes. All KISTERS production and assembly sites in Australia, New Zealand and Europe are ISO 90001 certified. All equipment is factory tested and/or factory calibrated before it is shipped to the client. This ensures that KISTERS products perform to their fullest capacity when delivered.

Despite KISTERS most rigorous quality assurance (QA), malfunction may occur within or outside of the warranty period. In rare cases, a product may not be delivered in accordance with your order.

In such cases KISTERS' return and repair policy applies. For you as a customer, this means the following:

- Contact KISTERS using the Repair Request Form and the Declaration of Contamination made available online:

Region (Language)	Download Link
Asia-Pacific (English)	Repair Request Form (APAC) Declaration of Contamination (APAC)
Europe, the Middle East and Africa (English)	Repair Request Form (EMEA) Declaration of Contamination (EMEA)
Germany (German)	Repair Request Form (DE) Declaration of Contamination (DE)

In response you will receive a reference number that must be referenced on all further correspondence and on the freight documents accompanying your return shipment.

- Please provide as much information and/or clear instructions within the return paperwork. This will assist our test engineers with their diagnosis.
- Please do not ship the goods prior to obtaining the reference number. KISTERS will not reject any equipment that arrives without reference number; however, it may take us longer to process.

Custom requirements for items sent to KISTERS for warranty or non-warranty repairs: Check with your national customs/tax authorities for details, processes and paperwork regarding tax exempt return of products. Typically, special custom tariff codes are available (such as HS Code = 9802.00) that verify the item is being returned for repair and has no commercial value. Please note that the customs invoice / dispatch documents should also clearly state: "Goods being returned to manufacturer for repair - No Commercial value". It is mandatory to have any returned goods accompanied by a commercial invoice on headed paper. KISTERS reserves the right to charge the customer for time spent rectifying incorrect customs documents.

Note: Please ensure that your goods are packed carefully and securely. Damage that occurs during transit is not covered by our warranty and may be chargeable.

9 Technical Data

Velocity Precision	0.001 m/sec or 0.01 ft/sec
Timing Accuracy	±0.1 s
Velocity Range	<ul style="list-style-type: none"> ▪ 0.015 m/sec to more than 6.1 m/sec ▪ Slow-speed mode: improves measurements with extremely slow rotating current meters (velocities less than 0.076 m/sec)
Operating Conditions	-5 °C to +50 °C, non condensing, IP66+, temporary immersion
Bluetooth®	Class 2, output power 2.5 mW (4 dBm), compliant Bluetooth® V1.1 (operating at 2.4 GHz)
Communications	RS232 Port (Tx, Rx) @ 19200 baud 8/N/1 (for reload of new firmware only)
Connections	2 × Banana plug sockets (meter input)
Visual Indicators	<ul style="list-style-type: none"> ▪ 128 × 64 graphics LCD, backlit ▪ 1 × orange LED, 1 × red / green / blue LED
Power Source	<ul style="list-style-type: none"> ▪ 3 × Internal AA alkaline 1.5 V batteries (not included) ▪ Low battery indication 2.8 V ▪ Hibernation after 5 min
Dimensions & Mass	140 × 80 × 50 mm (L × W × D), 400 g (with batteries)

10 Obligations of the Operator and Disposal

This chapter contains the following subsections:

- [Obligations of the Operator](#) ²³
- [Dismantling / Disposal](#) ²³

10.1 Obligations of the Operator

European Union

In the Single European Market it is the responsibility of the operator to ensure that the following legal regulations are observed and complied with: national implementation of the framework directive (89/391/EEC) and the associated individual directives, in particular 2009/104/EC, on minimum safety and health requirements for the use of work equipment by employees at work.

Worldwide

Regulations: If and where required, operating licences must be obtained by the operator. In addition, national or regional environmental protection requirements must be complied with, regardless of local legal provisions regarding the following topics:

- Occupational safety
- Product disposal

Connections: Local regulations for electrical installation and connections must be observed.

10.2 Dismantling / Disposal

When disposing of the units and their accessories, the applicable local regulations regarding environment, disposal and occupational safety must be observed.

Before dismantling

- Electrical Devices:
 - Switch off the units.
 - Disconnect electrical appliances from the power supply, regardless of whether the appliances are connected to the mains or to another power source.
- Mechanical devices:
 - Fix all loose components. Prevent the device from moving independently or unintentionally.
 - Loosen mechanical fastenings: Please note that appliances can be heavy and that loosening the fastenings may cause them to become mechanically unstable.

Disposal

Operators of old appliances must recycle them separately from unsorted municipal waste. This applies in particular to electrical waste and old electronic equipment.

Electrical waste and electronic equipment must not be disposed of as household waste!

Instead, these old appliances must be collected separately and disposed of via the local collection and return systems.

Integrated or provided batteries and accumulators must be separated from the appliances and disposed of at the designated

collection point. At the end of its service life, the lithium-ion battery must be disposed of according to legal provisions.

EU WEEE Directive

As players in the environmental market, KISTERS AG is committed to supporting efforts to avoid and recycle waste. Please consider:

- Avoidance before recycling!
- Recycling before disposal!



This symbol  indicates that the scrapping of the unit must be carried out in accordance with Directive 2012/19/EU. Please observe the local implementation of the directive and any accompanying or supplementary laws and regulations.

11 Appendices

This chapter contains the following subsections:

- [Capturing a Spin Test](#) ²⁵
- [Measuring Meter Dwell](#) ²⁸
- [Serial Port Echo Command](#) ²⁹
- [Example Calibration Certificate](#) ³⁰
- [Ground Feeler Device Model GFD](#) ³¹

11.1 Capturing a Spin Test

The spin test function allows the user to perform a simple spin test of the meter. The **PVD200** outputs a character string representing the meter count and elapse time. Whenever the 'spin test' measurement begins, the **PVD200** will output through the serial data port a character string at every contact closure. This character string is of the following format:

```
nxxx,tttt[cr][lf]
```

n = preamble for indicating contact closure data

xxx = number of meter contact closures, transmitted in decimal (i.e. 001, 002, 003, etc)

, = delimiter

tttt = counts of elapse time measured as 0.00666 second counts(150 Hz), transmitted in HEX ASCII (i.e. 0-9,A-F)

[cr] = carriage return (ASCII '0D')

[lf] = line feed (ASCII '0A')

At the end of the spin test, the **PVD200** sends a final data string that displays the total number of counts and total time all shown in decimal notation. This format makes it easy to copy the final total number of counts and total elapse time information onto a form. Total time is given in seconds and displays the time to a tenth of a second. The format is shown below.

```
dxxx,ttt.t[cr][lf]
```

d = preamble for indicating spin measurement data in decimal

xxx = number of meter contact closures, transmitted in decimal (i.e. 001, 002, 003, etc)

, = delimiter

ttt.t = total seconds of elapse time displayed to a tenth of a second

[cr] = carriage return (ASCII '0D')

[lf] = line feed (ASCII '0A')

Shown below is an example of both formats, as they would be displayed using the HyperTerminal program.

N	← Perform 'Spin Test'
n000,0000	← First contact closure
n001,0013	
n002,0027	
n003,003A	
.	
.	

.	
n162,427A	
n163,4607	← Final contact closure
n163,4736	← Data string when “Stop Spin” executed
d163,121.4	← Final meter counts and time (in seconds)
A	← PVD200 initialization completed

The following information details some specifics about each format, specifically the limitations and alternate characters that may be presented.

- 1) The maximum time that can be displayed, during the measurement, is 'FFFF₁₆'. If the measurement continues beyond the maximum data form available, the count 'rolls over' and begins from '0'. When this occurs, the delimiter character ';' is replaced by the '>' character to indicate the rollover condition. When the data is transferred to a spreadsheet, the character, '>', can be easily detected and used to add '65535' (= FFFF₁₆) to the elapse time tally. No further change in the delimiter character occurs if the accumulating time continues to further rollover.
- 2) The maximum time that can be displayed as given by the final data string is 436.4 seconds as displayed (FFFF₁₆ x 0.00666 seconds). This equates to 7 minutes and 16.4 seconds. If the accumulating time continues during the measurement (as discussed above), the final count tally will reflect a calculated value rolled over and beginning from '0'. If this occurs, the delimiter character ';' is replaced by the '>' character to indicate a rollover. To determine the total accumulated time from the roll over condition, simply add 436.4 seconds to the total number displayed.
- 3) The maximum number of measured meter contact closures (clicks) is 999. If the accumulating contact closures continues beyond the maximum data form, the count 'rolls over' and the most significant digit position number is replaced by the colon (':') character. If the count continues, other characters will replace the most significant digit position number. Meter counts should not exceed 999, however a detection scheme is provided if such an occurrence happens.

The “Spin Test” has three subcommands as follows:

S - Start spin measurement.

A - Stop spin measurement, transmit final results, then quit.

I - Abort or quit the “Spin Test” function. No final data is transmitted.

The “Spin Test” is performed in the following manner (through the serial interface) :

1. Before entering the “Spin Test” function, select the type of meter, i.e. Cat’s Whisker Head, or Magnetic Head Meter. Also enable or disable the buzzer.
2. Press “**N**” on the computer keyboard to enter the “Spin Test”. The **COUNT** LED will become illuminated. The **OPERATING STATUS** indicator will illuminate green if the meter is selected for a Magnetic Head and red if Cat’s Whisker Head is selected. The **PVD200** echoes with '**N**'.
3. Depress the letter “**S**” on the computer keyboard or press the **SELECT** button on the **PVD200**. The **OPERATING STATUS** indicator will turn off.
4. When the meter is spun, the **OPERATING STATUS** indicator will blink when a contact closure is detected.
5. The **PVD200** will output through the serial port a character string (as described previously) every time there is a meter contact closure. At the first contact closure, the **PVD200** outputs the first contact closure as the start of the measurement. The number of meter contact closures begins with “zero” and the counts of elapsed time begins with “zero.” Contact closures and counts of elapsed time will begin to increment following every contact closure until the “A” command is sent or the **SELECT** button is pressed. The **PVD200** then sends the final data string (in decimal) followed by the **PVD200** reinitializing. The character 'A' is sent when the **PVD200** completes a calibration cycle, as it initializes.

Sending the 'I' command anytime before or during the test aborts (or quits) the “Spin Test” function. The **PVD200** sends the character 'A' to acknowledge exiting. When the **PVD200** exits, the **PVD200** reinitializes with a calibration. When the calibration has been completed, the **PVD200** sends the character 'A' again, and then goes to normal operation mode.

Capturing a “Spin Test” file

“Spin test” transmitted data can be saved by using the options in the HyperTerminal program. HyperTerminal is a program that can be found on most computers in the ‘Accessories’ folder listed in the Programs list on the desktop. Within HyperTerminal and before spinning the meter, select “Capture Text” found in the Windows label “Transfer” tab. When the “Capture Text” tab is

clicked, Windows will ask for a file name. The file name extension will be “.txt”. Select a file name, then click “Start” to save the screen results. After completing the spin test, select “Capture Text” again under the “Transfer” tab. Click “Stop”. The file will be saved under the file name given. The file can be opened using Windows “NotePad” or “WordPad” and can be easily imported into Excel for analysis.

To better align the data being displayed, the **PVD200** will respond to the Carriage Return key, $\text{CR} \rightarrow$. Entering a $\text{CR} \rightarrow$, the **PVD200** will send a $\text{CR} \rightarrow$ followed by a Line Feed, $\text{LF} \downarrow$. This will cause the display cursor to return to the left most position on the display and move down the page by one line position.

Use the following steps to import a text file into Excel. This procedure uses Microsoft Excel 2000.

1. Open up Excel for Windows.
2. Under the ‘Data’ tab, select ‘Get External Data’.
3. Within ‘Get External Data’, select ‘Import Text File’.
4. Select the location of the text file and click ‘Import’.
5. The ‘Text Import Wizard’ pops up with the ‘Delimited’ radio button on. Also, a portion of the actual text file is shown at the bottom of the window.
6. Click up the ‘Start import at row:’ tab to start at row 2.
7. Click ‘Next’ at the bottom to go to Step 2 of the Wizard.
8. In the ‘Delimiters’ window,
 - a) deselect ‘Tab’,
 - b) select ‘Comma’,
 - c) select ‘Other’, then type ‘n’ in the box next to ‘Other’.
 - d) The text file preview should show a vertical line separating the meter counts column data and the time data column.
9. Click ‘Next’, this will bring you to Step 3 of the Wizard.
10. In Step 3 window, click ‘Do not import column (skip)’ in the ‘Column data format’ window. This will show ‘Skip’ in the column 1 heading.
11. Click on column 3 (where the Time data is shown in HEX-ASCII) and change in the ‘Column data format’ window from ‘General’ to ‘Text’.
12. In the ‘Data Preview’ window, the columns should show the following selections on the column heading:
 - a) ‘Skip’ for column 1
 - b) ‘General’ for column 2–Current meter counts
 - c) ‘Text’ for column 3–Time
13. Click ‘Finish’, and then click ‘OK’ to import data into the existing worksheet.
14. Save the workbook under a file name.
15. Shown below is an example of an imported ‘Spin Test’ file.

	A	B	C	D	E	F	G	H	I	J	K
1	0	0000									
2	1	0013									
3	2	0027									
4	3	003A									
5	4	004F									
6	5	0063									
7	6	0078									
8	7	008D									
9	8	00A2									
10	9	00B8									
11	10	00CE									
12	11	00E4									
13	12	00FA									
14	13	0111									

Shown in the figure below is an example of a graph showing the response of a current meter created from data in a “Spin Test” file.

Spin Test for Meter 1234567

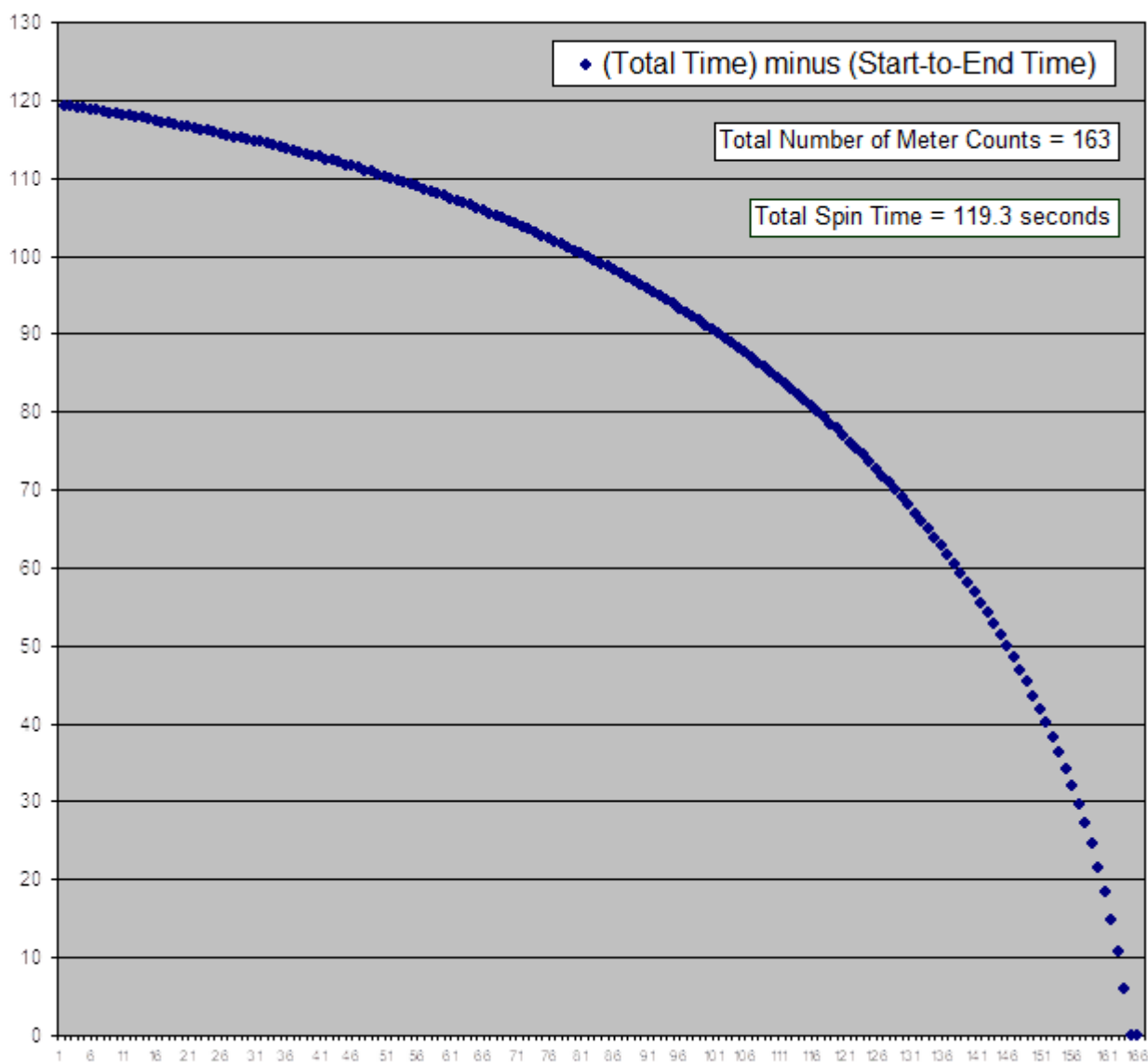

11.2 Measuring Meter Dwell

The meter dwell measurement function performs a measure of the contact time in relation to a single rotation of the meter. For the cat's whisker contact, it is the measure of the cat's whisker contact time on the cam lobe. The resulting measurement is called "dwell". Dwell is expressed in terms of degrees and for a cat's whisker contact; the contact time should be adjusted to be the width of a single cup. This adjustment results in the dwell angle of 60° for a meter with 6 cups and represents optimum performance. The magnetic contact meter (Mag Head) requires no adjustment and therefore measuring the meter dwell angle does not apply but can be performed. When a meter dwell measurement is performed, the **PVD200** takes three measurements and displays the result on the LCD after each measurement, as shown.

The "Dwell Angle" can be computed by using the following simple formula:

$$\text{Dwell Angle} = \frac{(\text{Contact time}) \times 360}{(\text{Total Time})}$$

The contact time and total time shown above in the formula are expressed in terms of the number of samples measured at a sample rate of 1200 Hz as it is measured by the **PVD200**. A high sample rate is used to reflect a more accurate measure of the contact time and total time measured. The repeatability and variability in measuring the dwell is directly related to mechanical factors such as the condition of the pivot bearings, and the cat whisker wire contact surface and cam lobe. Wide variations in

readings reflect conditions that may require further inspection of the meter and its mechanical parts. Some variation in readings is acceptable and represents proper adjustment; however there should be no more than a 10% difference between all the readings. Optimal setting is near 60° (a single meter cup width). High conductivity of $>25,000$ micro Siemens can affect the operating performance of the **PVD200** and should a current meter be required to operate in high conductivity water, a lower dwell angle setting should be used. A setting of not less than 20° for higher velocities (>2 ft/sec or 0.65 m/sec) is suggested.

11.3 Serial Port Echo Command

The **PVD200** has a special serial port character echo command that can be used to echo characters or short strings appearing through the serial port. The command can be used to 'see' what characters are being transmitted to the **PVD200**. This command can be useful to software application developers. To invoke the command, simply send the single ASCII character '~'. On a laptop keyboard, this character is located on the numbers key row and is the left most character key in the row. The character is a shift key character and the 'shift' key must be used to send the character. This echo character command acts like a switch which turns On character echo or turns Off character echo. When 'character echo' is turned On, any character received through the serial interface is echo'd back through the port and any character sent will not be interpreted as a function or operating command to the **PVD200**.

Shown below is a simple pictorial of the Serial Port function of the **PVD200**. Using **Bluetooth®** and an additional serial port device connected to the hardware port of the **PVD200**, can assist developers in their applications and 'seeing' what commands are sent to the **PVD200**.

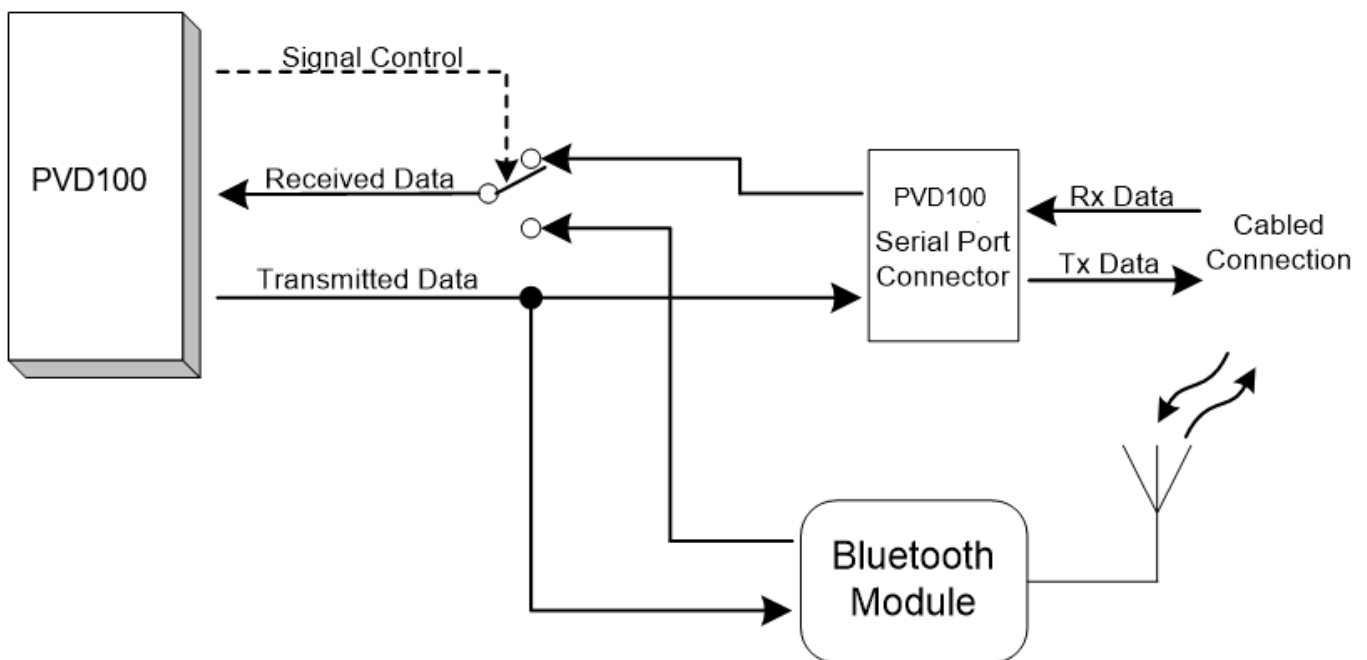

11.4 Example Calibration Certificate

HYQUEST SOLUTIONS PTY. LTD., AUSTRALIA

CERTIFICATE OF CALIBRATION Date: 27/4/06

Current Meter Model: xxxxxx

Serial No. 91655

Fan No. 1

Serial No. 165435

Diameter: 125mm

Pitch: 0.25m

Type of Support:

Method of Calibration: Average Value Equation

$n < 0.42$	$V = 0.2190 n + 0.0153 \text{ m/s}$
$0.42 < n < 3.73$	$V = 0.2459 n + 0.0041 \text{ m/s}$
$n > 3.73$	$V = 0.2508 n - 0.0142 \text{ m/s}$

Range Values

First Term
(Slope)

Second Term
(Intercept)

Starting Velocity = 0.025 m/s

Maximum Velocity = 5.000 m/s

Note: 'n' denotes the number of revolutions of the propeller per second
'V' is the water velocity in meters per second.

Date: 27/4/06

INSPECTED: _____

Anthony Gemayel
(Mechatronics Engineer)

The above meter has been calibrated in accordance with AS 3778.6.3-1992. This standard is identical with and has been reproduced from ISO 3455:1976.
The clause below has been printed with the permission of Standards Australia from AS 3778.6.1-1992. This standard is identical with and has been reproduced from ISO 2537:1988. Clause 7.6 Recalibration. Meters shall be recalibrated whenever their performance is suspect. In practice for individually rated meters, recalibration is sometimes carried out at yearly intervals or after 300 hours of use, whichever is the shorter.

D127.08.00

11.5 Ground Feeler Device Model GFD

Introduction

The Ground Feeler Device is a mechanical spring loaded attachment that can be used in conjunction with any gauging winches fitted with Amergraph cable and connected to a Columbus pattern gauging weight.

The unit is designed to alert the operator that the gauging weight has come in contact with the streambed during a gauging operation.



Figure 1 – Ground Feeler Device Model GFD

Note:

A current meter cable is supplied with the Ground Feeler Device (GFD) so it can be connected to the operator's current meter. The customer must specify the lead type when ordering the GFD:

GFD02-AA for AA type current meters

GFD02-RB for Redback type current meters

GFD02-UNI for Universal Type Current Meters (OSS-B1/OTT-C31)

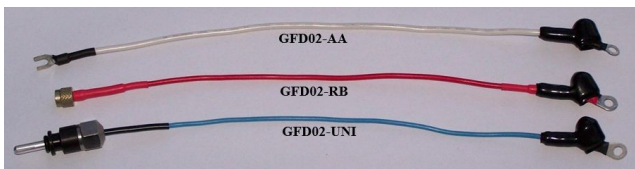
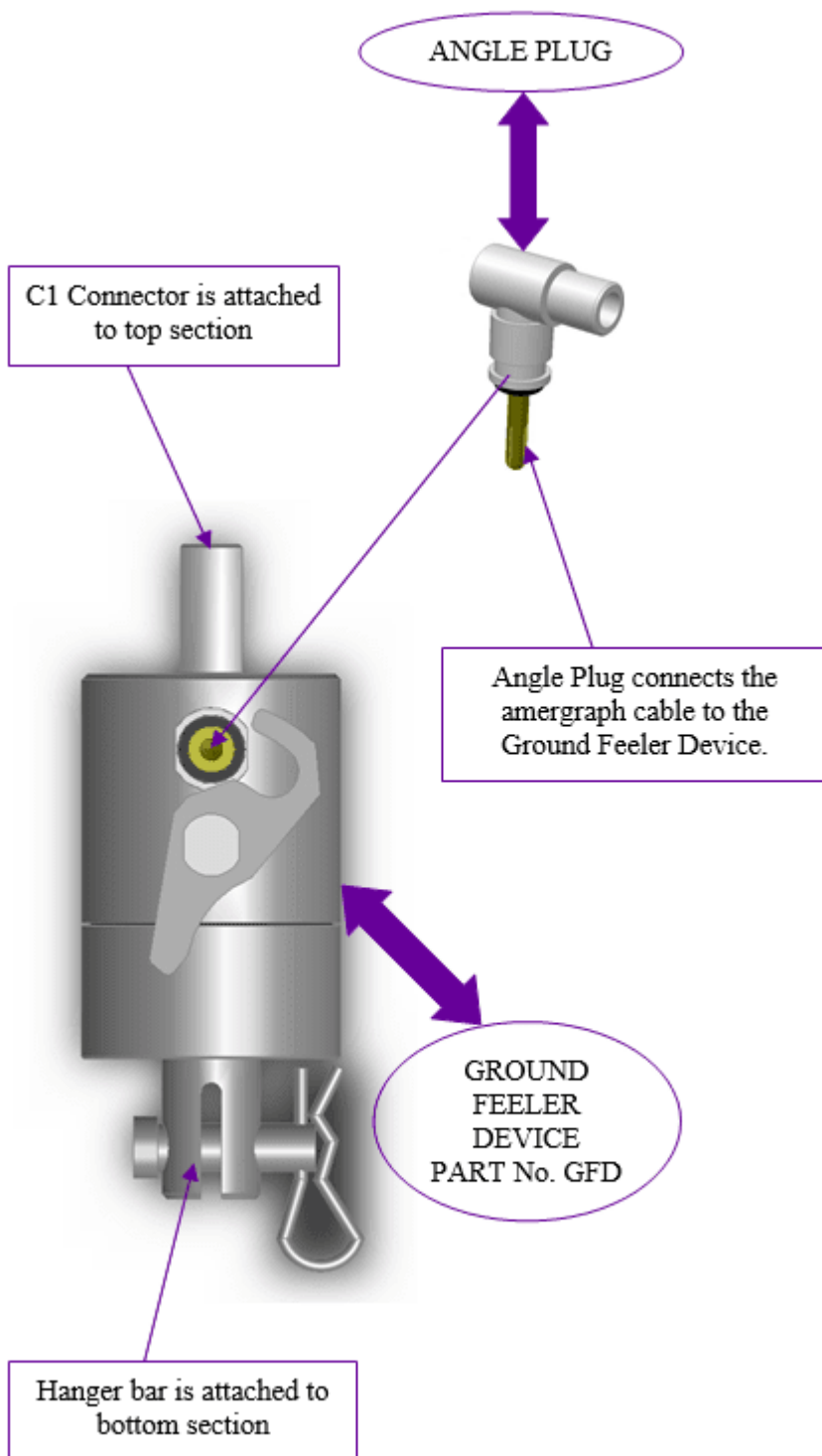

Figure 2 – Current Meter Cable

When the gauging weight contacts the streambed, the GFD causes the current meter signal to short-circuit. The Buzzer option on the **PVD200** should be set to "En→Full", and the buzzer will beep continuously indicating the gauging weight is in contact with the streambed. Once the weight is raised slightly off the streambed, the orange led will turn "OFF" and normal current meter signal operation will continue.

The GFD eliminates the need to observe the main cable movement on a cableway to determine if the gauging weight comes into contact with the streambed. In situations where the distance is too far to observe the main cable movement, or in a harsh weather conditions, the GFD makes streambed sensing an easy and accurate procedure.

Installation



Operation

- The GFD contact plunger shown in normal gauging position when Columbus weight is attached (i.e. no contact)

Gauging weight is attached; The contact pin moves away from the angle plug contact sleeve (open contact).

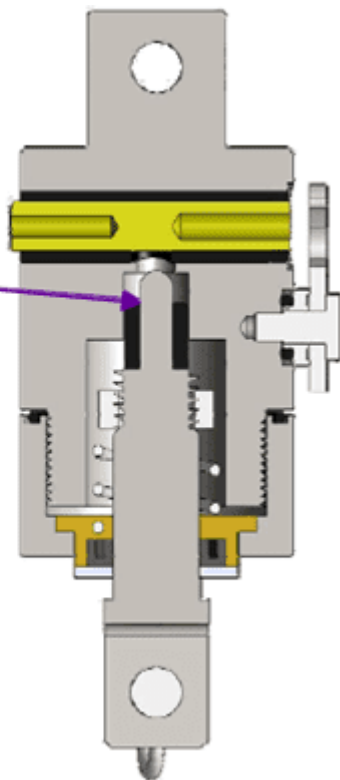

- The GFD spring moves plunger into contact position when Columbus weight reaches the streambed (i.e. continuous beep or no signal received from current meter)







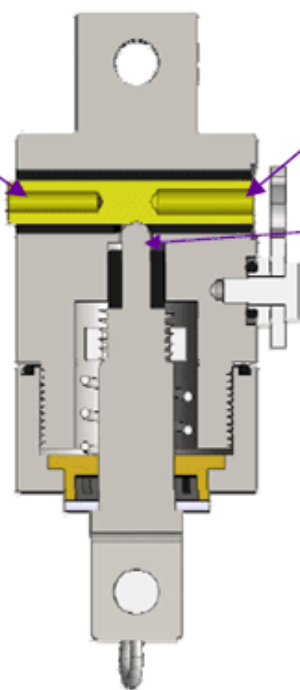









This side is attached to current meter cable (GFD02-AA or GFD-RB or GFD02-OSS). Customer to specify lead when ordering.

This side is attached to Amegraph cable angle plug.

Gauging weight attached; The pin is making contact with the Angle Plug connecting sleeve (closed contact); Gauging weight has reached streambed.



Contact Data

Europe	KISTERS Europe	 +49 2408 9385 0
		 hydromet.sales@kisters.eu
		 www.kisters.eu
Australia	KISTERS Australia	 +612 9601 2022
		 sales@kisters.com.au
		 www.kisters.com.au
New Zealand	KISTERS New Zealand	 +64 7 857 0810
		 sales@kisters.co.nz
		 www.kisters.co.nz
Latin America	KISTERS Latin America	 +57 350 575 4079
		 sales@kisters-latam.com
		 www.kisters-latam.com
North America	KISTERS North America	 +1 561 459 4876
		 kna@kisters.net
		 www.kisters.net
Spain	KISTERS Ibérica	 info@kisters.es
		 www.kisters.es

