

The logo for HydroMet, featuring a white diagonal slash followed by the text "HydroMet" in a bold, white, sans-serif font.

/ HydroMet

User Manual

TSR-MKII

The KISTERS logo, consisting of a white diagonal slash followed by the word "KISTERS" in a bold, white, sans-serif font, with the tagline "Empowering decisions of tomorrow" below it.

KISTERS
Empowering decisions of tomorrow

Table of Contents

I	Disclaimer	3
II	Safety Instructions	4
Part I	Introduction	5
Part II	Installation	6
2.1	Unpacking	6
Part III	Configuration	7
Part IV	Operation	8
4.1	Metric Rods	9
Part V	Maintenance	18
Part VI	Repair	19
6.1	Part List	20
Part VII	Technical Data	23
Part VIII	Obligations of the Operator and Disposal	24
8.1	Obligations of the Operator	24
8.2	Dismantling / Disposal	24

I Disclaimer

The information provided in this manual was deemed accurate as of the publication date. However, updates to this information may have occurred.

This manual does not include all of the details of design, production, or variation of the equipment nor does it cover every possible situation which may arise during installation, operation or maintenance. KISTERS shall not be liable for any incidental, indirect, special or consequential damages whatsoever arising out of or related to this documentation and the information contained in it, even if KISTERS has been advised of the possibility of such damages.

Any errors found in any KISTERS product should be reported to KISTERS where every effort will be made to quickly resolve the problem.

Copyright Notice: No parts of this work may be reproduced in any form or by any means without the written permission of the publisher. KISTERS waives copyright for users to print out parts of the documentation in hard copy for their own use only.

Trademark Notice: KISTERS products and services referred to in this document are trademarks or registered trademarks of KISTERS. Other product names used may or may not be the trademarks of their respective owners.

© 2025 | KISTERS. Any rights not expressly granted herein are reserved.

II Safety Instructions

- Read the user manual including all operating instructions prior to installing, connecting and powering up the KISTERS TSR-MKII. The manual provides information on how to operate the product. The manual is intended to be used by qualified personnel, i.e. personnel that have been adequately trained, are sufficiently familiar with installation, mounting, wiring, powering up and operation of the product.
- Keep the user manual on hand for later reference!
- If you encounter problems understanding the information in the manual (or part thereof), please consult the manufacturer or its appointed reseller for further support.
- KISTERS TSR-MKII is intended to be used in hydrometeorological or environmental monitoring applications.
- Before starting to work, you have to check the functioning and integrity of the system.
 - Check for visible defects on the TSR-MKII, this may or may not include any or all of the following mounting facilities, connectors and connections, mechanical parts, internal or external communication devices, power supplies or power supply lines, etc.
 - If defects are found that jeopardize the operational safety, work must be stopped. This is true for defects found before starting to work as well as for defects found while working.
- Do not use the KISTERS TSR-MKII in areas where there is a danger of explosion.
- The present user manual specifies environmental/climatic operating conditions as well as mechanical and electrical conditions. Installation, wiring, powering up and operating the KISTERS TSR-MKII must strictly comply with these specifications.
- Perform maintenance only when tools or machinery are not in operation.
- If guards are removed to perform maintenance, replace them immediately after servicing.
- Never make any electrical or mechanical diagnostics, inspections or repairs under any circumstances. Return the product to the manufacturer's named repair centre. You can find information on how to return items for repair in the relevant section of the KISTERS website.



Disposal instructions: After taking the KISTERS TSR-MKII out of service, it must be disposed of in compliance with local waste and environmental regulations. The KISTERS TSR-MKII is never to be disposed in household waste!



Inputs and outputs of the device are protected against electric discharges and surges (so-called ESD). Do not touch any part of the electronic components! If you need to touch any part, please discharge yourself, i.e. by touching grounded metal parts.

1 Introduction

Thank you for choosing our product. We hope you will enjoy using the device.

KISTERS manufactures, sells, installs and operates quality instrumentation, data loggers and communication technology. Products are designed with passion for environmental monitoring and with a deep understanding of the quality, accuracy and robustness needed to fulfil the requirements of measurement practitioners in the field.

The present User Manual will help you understand, install and deploy the device. If, however, you feel that a particular information is missing, incomplete or confusing, please do not hesitate to contact us for further support!

The model TSR MKII Top Setting Wading Rods were developed to simplify the task of carrying out gauging in small streams. The TSR MKII shall only be used in shallow streams, where it is safe for the hydrographer to carry out gauging while wading.

The TSR has a usable depth of 1.2 meters.

The device:

- ensures the stable placement of the rod on the stream bed.
- allows the depth of the stream to be measured.
- enables the hydrographer to precisely position the current meter at 0.2, 0.4, 0.6 and 0.8 of water depth without removing the rod from the stream bed.
- allows the direct connection of the current meter and pulse counter without external cables.

The Top Setting Wading Rods are manufactured from durable materials selected to meet the environmental conditions in the field.

2 Installation

This chapter contains the following subsection:

- [Unpacking](#)

2.1 Unpacking

Remove the packing material from the TSR MKII canvas bag.

This product has been inspected to ensure compliance with your purchase order and has been appropriately packed to ensure the safe transit to your warehouse, however a thorough inspection of the product should be carried out upon receipt to confirm compliance and to identify any damage that may have occurred during transit.

Any short supply or damage should be reported to KISTERS within seven days of receipt of the product.

The KISTERS Model TSR MKII Top Setting Wading Rods have been pre-assembled in the factory and are ready for service.

This product does **NOT** include a pulse counter or current meter unless specifically requested in the purchase order.

3 Configuration

TSR-MKII is a purely mechanical instrument. No specific configuration is required.

Please follow [installation instructions](#) .

4 Operation

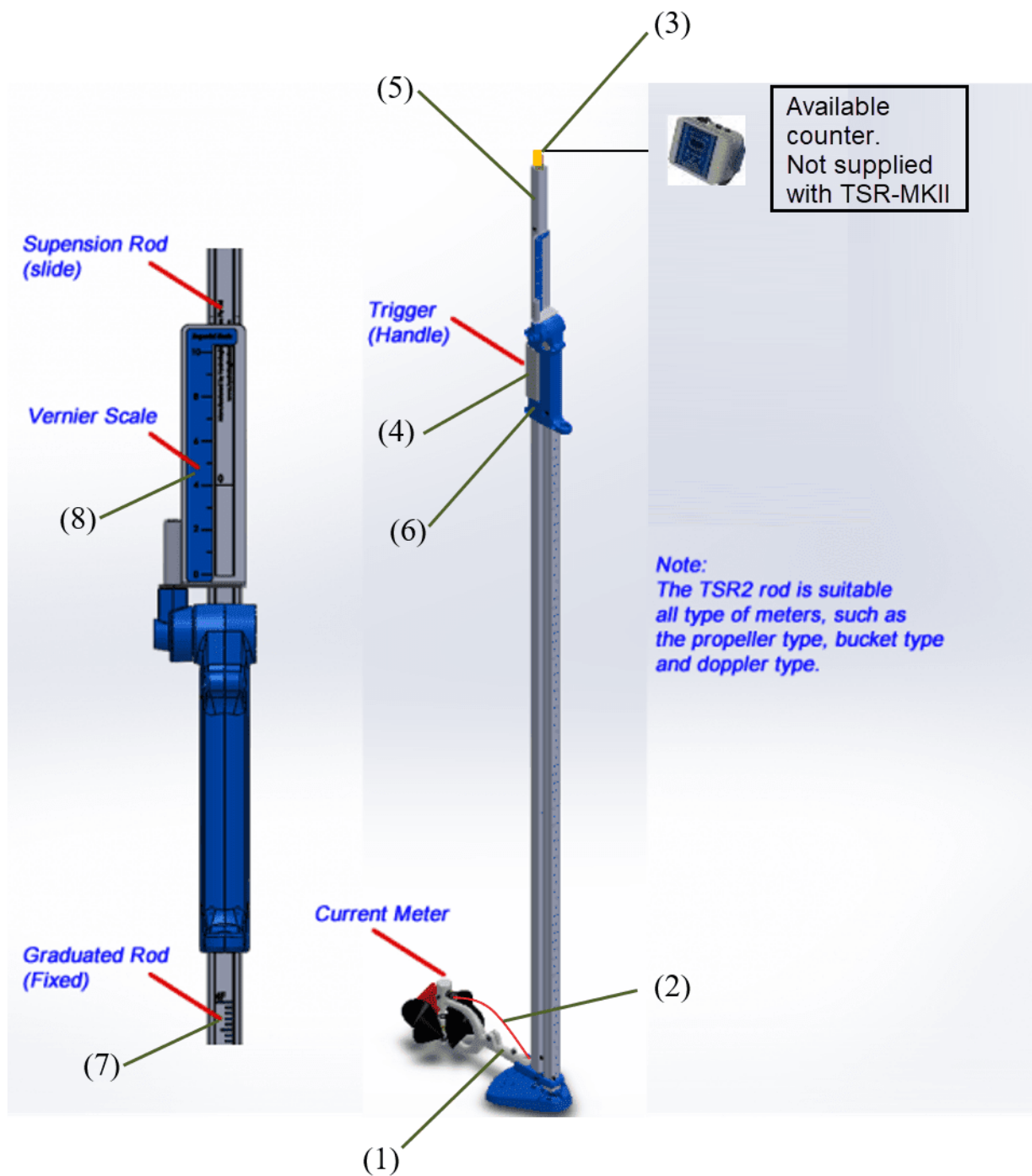

Figure 1 - Diagram 1

Preparation - refer to Diagram above

Position the appropriate current meter, complete with fan on the METER MOUNTING and secure with screw (1).

Connect CABLE to current meter (2).

Position the pulse counter on PIN and connect lead to CONTACT (3).

Depress TRIGGER (4) the SUSPENSION ROD (5), complete with the current meter, to slide within the HAND GRIP BODY (6).

Ensure that the suspension rod slides smoothly for its full length.

Do not permit the current meter to fall to the foot as damage to the meter may occur.

Power up the pulse counter (current meter counter) and carry out function test as per manufacturer's instructions. Rotate the current meter fan to generate pulses then check that the pulses are being received by the pulse counter. The device is now ready for operation.

An appropriate stream cross section should have been previously selected and set up for gauging.

Operation

Place the Top Setting Wading Rod vertically in the stream at the appropriate point in the cross section, ensuring that the base plate is stable and that the meter is directed into the flow.

Read off the depth of stream on the GRADUATED ROD (7).

Relationship between the GRADUATED ROD (7) & the SUSPENSION ROD (5)

The GRADUATED ROD (7) is designed for measurement of individual soundings across the stream section. This rod is graduated with markings every 20 millimetres.

NB: The graduations on the SUSPENSION ROD (5) and VERNIER SCALE (8) are NOT to be used for direct measurement of soundings. These graduations on these Items have been designed for accurate setting of the current meter to the required 'depth of observation'.

For more information, see the following subsections:

- [Metric Rods](#)

4.1 Metric Rods

The rod is graduated in 20 millimetres graduations. To assist in the reading, the rod is marked with a triple groove at 500 millimetre graduations, double groove at 100 millimetre graduations and single groove at 20 millimetre graduations.

With respect to the GRADUATED ROD (7), the stream bed is the zero reference.

The current meter can be readily set at 0.2, 0.4, 0.6 and 0.8 of the sounding by aligning the appropriate graduation on the SUSPENSION ROD (5) with the appropriate graduation on the VERNIER SCALE (8).

The correct 'depth of observation' for current meter velocity measurement, is based on a multiplier, which when applied to the measured sounding (i.e. that taken from the GRADUATED ROD (7) requires the application of a multiplier to calculate the correct setting to be used on the SUSPENSION ROD (5). The table below summarises the various multiplier to be used, based on required depth of observation:

Multiplier Table

Depth of Observation	0.2d	0.4d	0.6d	0.8d
Multiplier Used	2.0	1.5	1.0	0.5

Where d = sounding taken from GRADUATED ROD (7)

Refer to the following examples.

Example 1 - The sounding has been read at 5 decimetres (500 mm) on the GRADUATION ROD (7).

Setting at 0.2d

1. From the table above, the calculated reading is '**10**' (i.e. multiplier '2.0' * sounding '5').
2. To set the current meter at 0.2 of the 5 decimetre sounding, depress the TRIGGER (4) and slide the SUSPENSION ROD (5) until the graduation mark '**10**' on the suspension rod is in line with graduation '**0**' on the VERNIER SCALE (8).

Metric Rod Instruction

Water Level = 5 dm
Note expressed in
Decimetres

Current Meter sitting
@ 400mm 0.2d of
water level

Therefore, as discussed before @
0.2d the multiplier is 2.0, which
means the multiplier x the water
level = $2.0 \times 5.0 = 10$
So, if the number 10 on the
suspension rod is set to 0 on the
vernier scale this will set the
measurement @ 0.2d

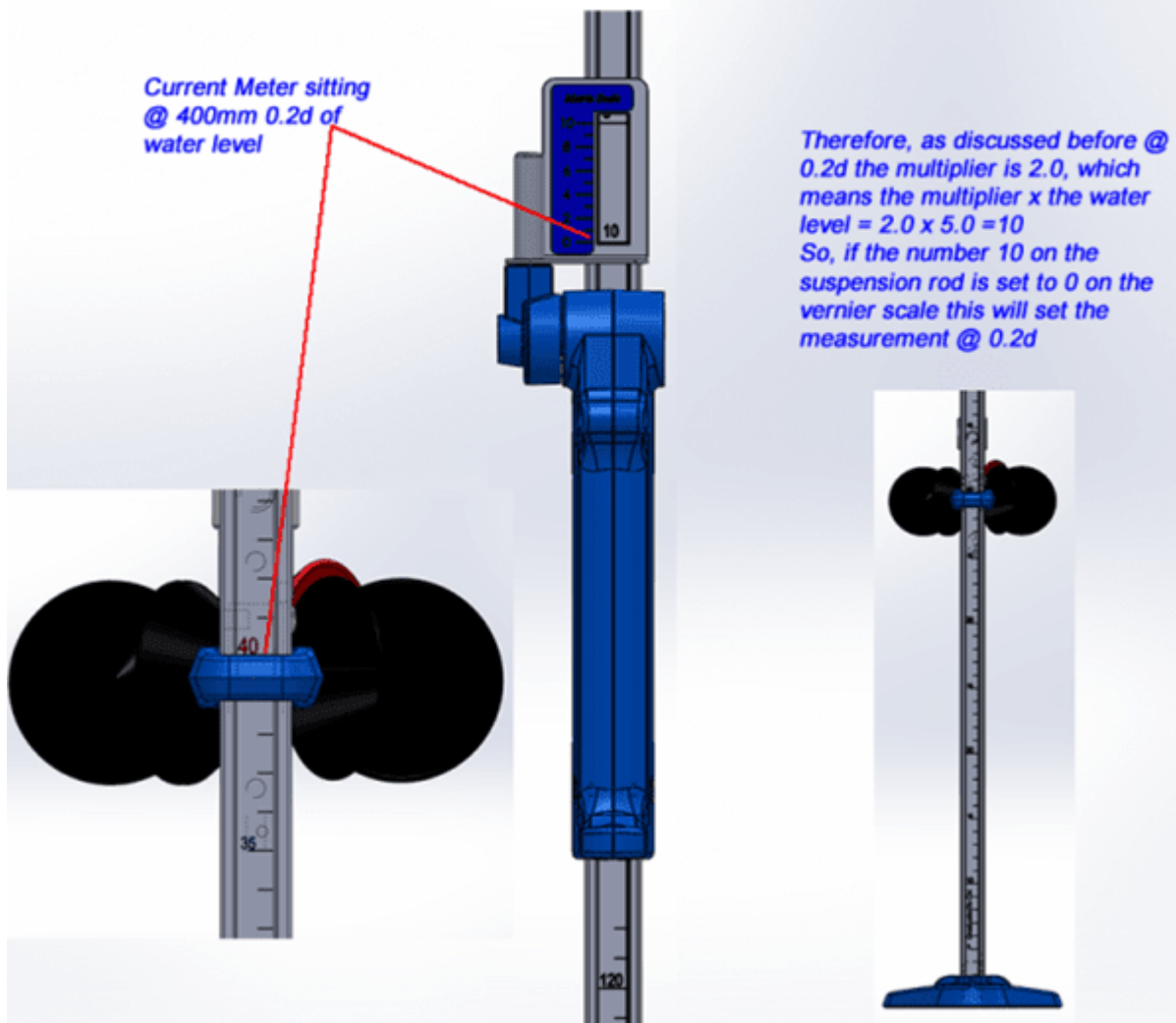

3. Release the trigger.
4. This will position the current meter at 4.0 decimetres (i.e. 400 mm) on the GRADUATED ROD (0.2 of sounding).

Setting at 0.4d

1. From the table above, the calculated reading is '7.5' (i.e. multiplier '1.5' * sounding '5').
2. To set the current meter at 0.4 of the 5 decimetre sounding, depress the TRIGGER (4) and slide the SUSPENSION ROD (5) until the graduation mark '7' on the suspension rod is in line with graduation '5' on the VERNIER SCALE (8).

Metric Rod Instruction

Water Level = 5 dm
Note expressed in
Decimetres

Current Meter sitting
@ 300mm 0.2d of
water level

Therefore, as discussed before @
0.4d the multiplier is 1.5, which
means the multiplier x the water
level = $1.5 \times 5.0 = 7.5$
So, if the number 7 on the
suspension rod is set to 5 on the
vernier scale this will set the
measurement @ 0.4d

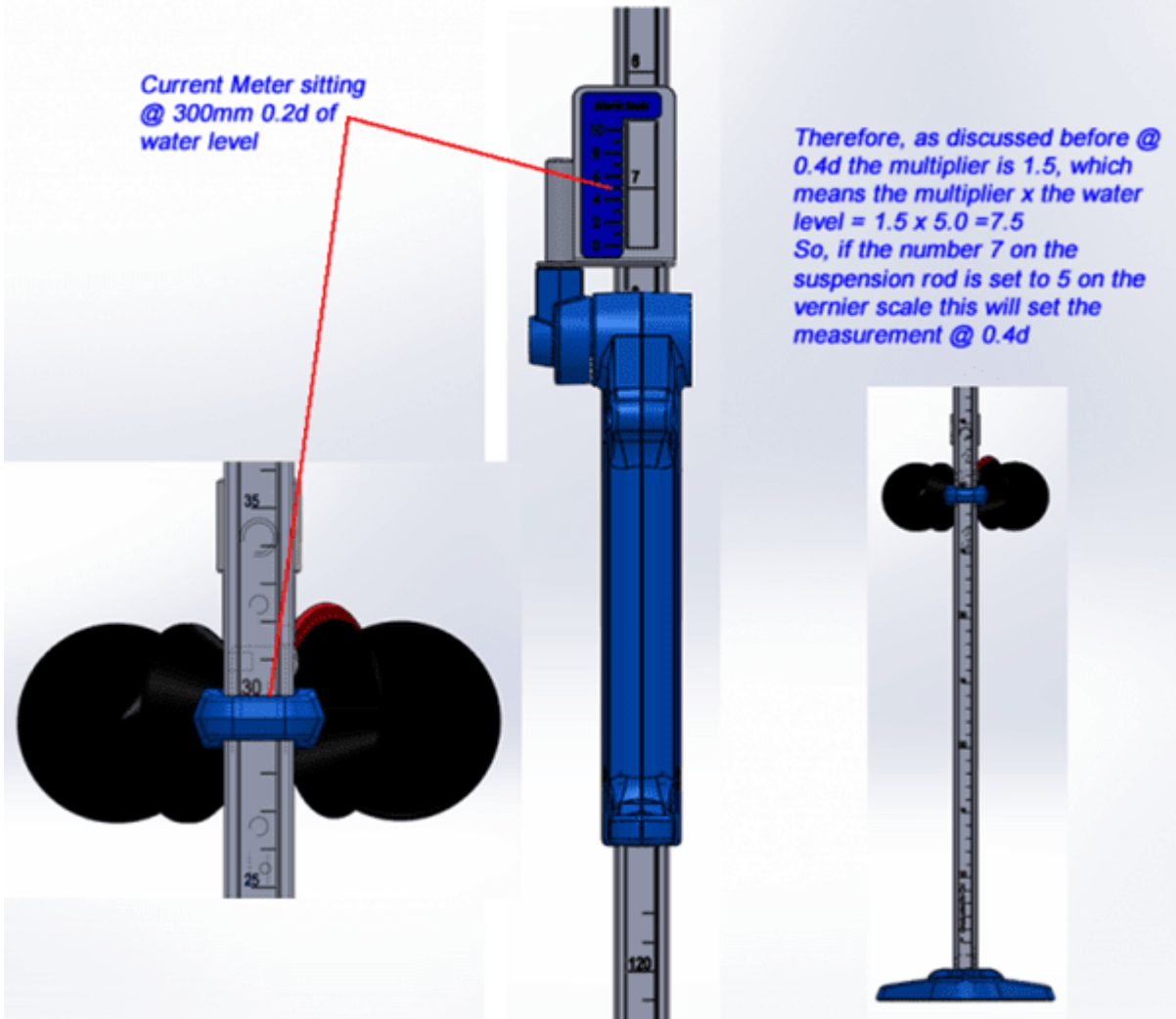

3. Release the trigger.
4. This will position the current meter at 3.0 decimetres (i.e. 300 mm) on the GRADUATED ROD (0.4 of sounding).

Setting at 0.6d

1. From the table above, the calculated reading is '5' (i.e. multiplier '1.0' * sounding '5').
2. To set the current meter at 0.6 of the 5 decimetre sounding, depress the TRIGGER (4) and slide the SUSPENSION ROD (5) until the graduation mark '5' on the suspension rod is in line with graduation '0' on the VERNIER SCALE (8).

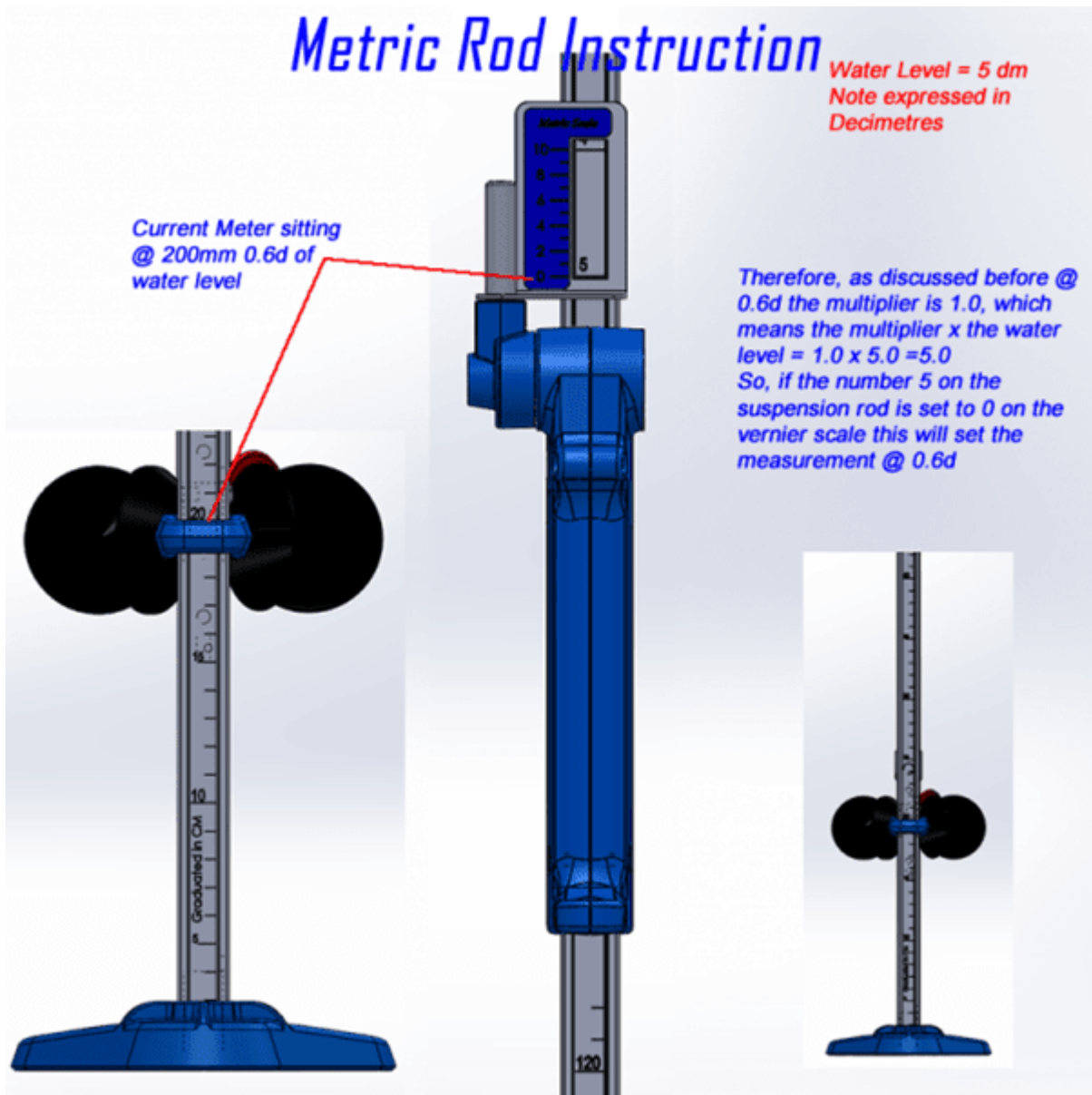

3. Release the trigger.
4. This will position the current meter at 2.0 decimetres (200 mm) on the GRADUATED ROD (0.6 of sounding).

Setting at 0.8d

1. From the table above, the calculated reading is '**2.5**' (i.e. multiplier '0.5' * sounding '5').
2. To set the current meter at 0.8 of the 5 decimetre sounding, depress the TRIGGER (4) and slide the SUSPENSION ROD (5) until the graduation mark '**2**' on the suspension rod is in line with graduation '**5**' on the VERNIER SCALE (8).

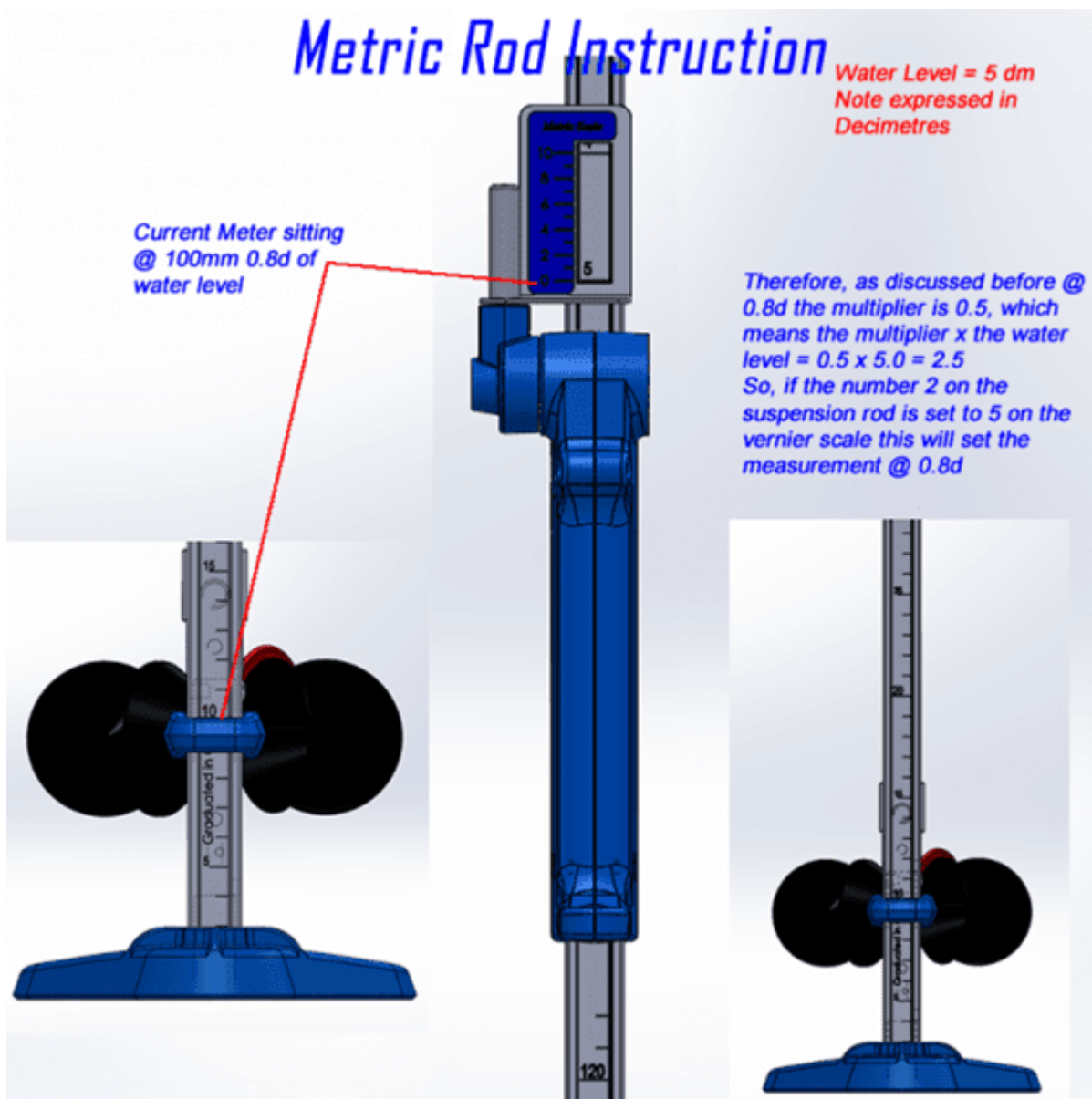

3. Release the trigger.
4. This will position the current meter at 1.0 decimetres (100 mm) on the GRADUATED ROD (0.8 of sounding).

Example 2 The sounding has been read at 5.2 decimetres or 520 mm on the GRADUATION ROD (7)

Setting at 0.2d

1. From the table above, the calculated reading is '**10.4**' (i.e. multiplier '2.0' * sounding '5.2').
2. To set the current meter at 0.2 of the 5.2 decimetre sounding, depress the TRIGGER (4) and slide the SUSPENSION ROD (5) until the graduation mark '**10**' on the suspension rod is in line with graduation '**4**' on the VERNIER SCALE (8).

Metric Rod Instruction

Water Level = 5 dm
Note expressed in Decimetres

Current Meter sitting
@ 420mm 0.2d of
water level

Therefore, as discussed before @ 0.2d the multiplier is 2, which means the multiplier x the water level = $2 \times 5.2 = 10.4$
So, if the number 10 on the suspension rod is set to 4 on the vernier scale this will set the measurement @ 0.2d

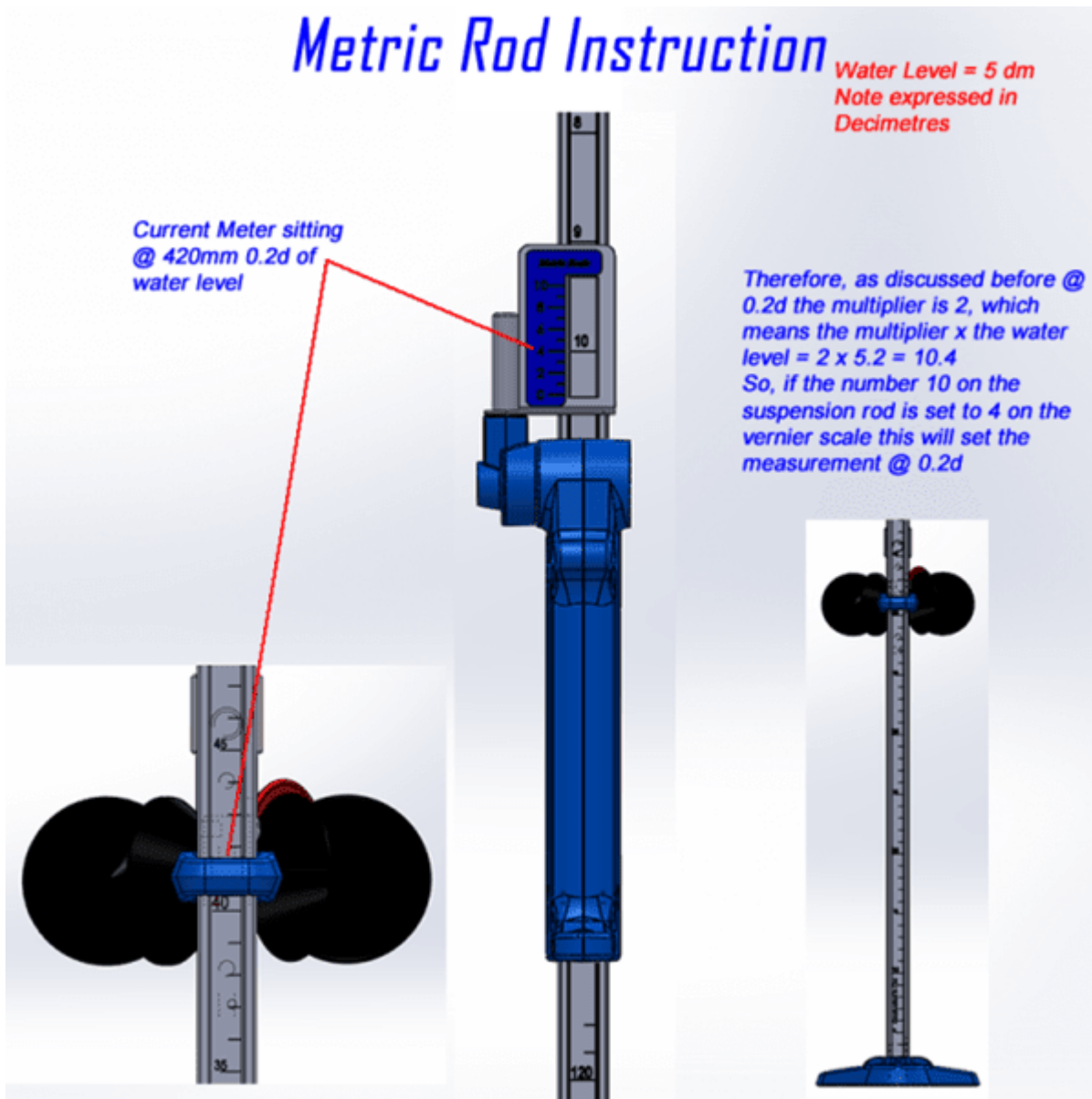

3. Release the trigger.
4. This will position the current meter at 4.2 decimetres (420 mm) on the GRADUATED ROD (0.2 of sounding).

Setting at 0.4d

1. From the table above, the calculated reading is '**7.8**' (i.e. multiplier '1.5' * sounding '5.2').
2. To set the current meter at 0.4 of the 5.2 decimetre sounding, depress the TRIGGER (4) and slide the SUSPENSION ROD (5) until the graduation mark '**7**' on the suspension rod is in line with graduation '**8**' on the VERNIER SCALE (8).

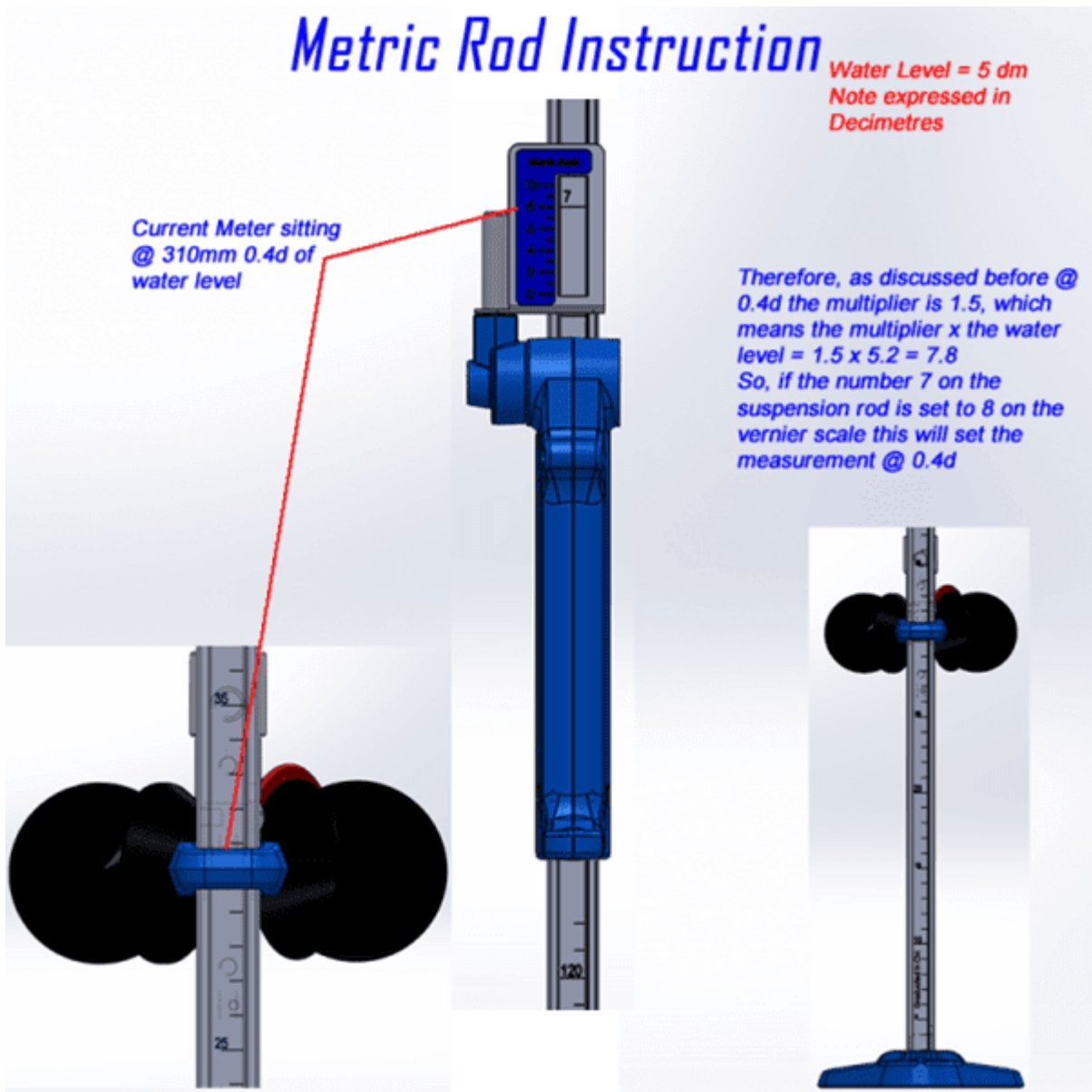

3. Release the trigger.
4. This will position the current meter at 3.1 decimetres (310 mm) on the GRADUATED ROD (0.4 of sounding).

Setting at 0.6d

1. From the table above, the calculated reading is '**5.2**' (i.e. multiplier '1.0' * sounding '5.2').
2. To set the current meter at 0.6 of the 5.2 decimetre sounding, depress the TRIGGER (4) and slide the SUSPENSION ROD (5) until the graduation mark '**5**' on the suspension rod is in line with graduation '**2**' on the VERNIER SCALE (8).

Metric Rod Instruction

Water Level = 5 dm
Note expressed in Decimetres

Current Meter sitting
@ 210mm 0.6d of
water level

Therefore, as discussed before @ 0.6d the multiplier is 1.0, which means the multiplier x the water level = $1.0 \times 5.2 = 5.2$
So, if the number 5 on the suspension rod is set to 2 on the vernier scale this will set the measurement @ 0.6d

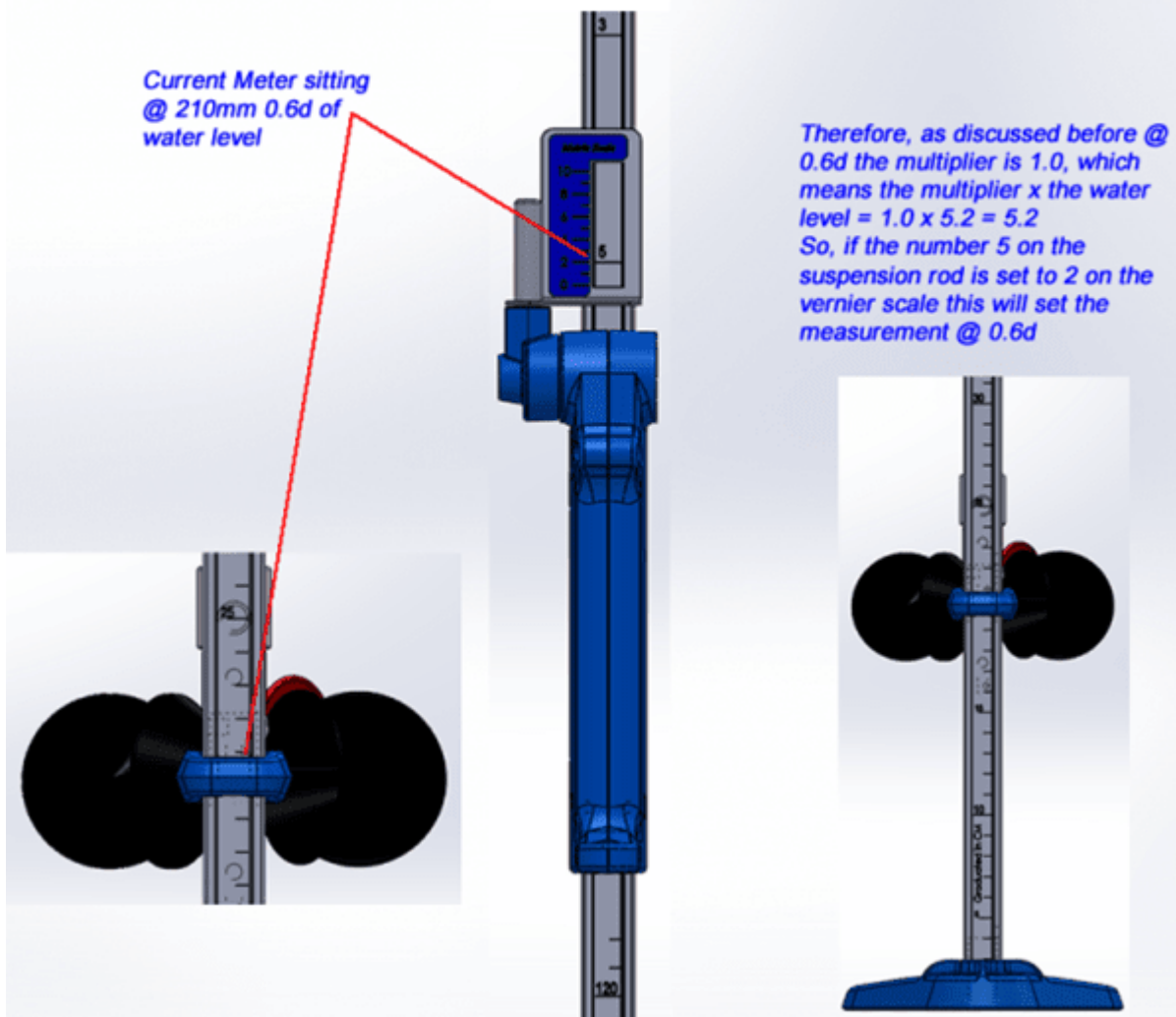

3. Release the trigger.
4. This will position the current meter at 2.1 decimetres (210 mm) on the GRADUATED ROD (0.6 of sounding).

Setting at 0.8d

1. From the table above, the calculated reading is '**2.6**' (i.e. multiplier '0.5' * sounding '5.2').
2. To set the current meter at 0.8 of the 5.2 decimetre sounding, depress the TRIGGER (4) and slide the SUSPENSION ROD (5) until the graduation mark '**2**' on the suspension rod is in line with graduation '**6**' on the VERNIER SCALE (8).

Metric Rod Instruction

Water Level = 5 dm
Note expressed in
Decimetres

Current Meter sitting
@ 110mm 0.8d of
water level

Therefore, as discussed before @
0.8d the multiplier is 0.5, which
means the multiplier x the water
level = $0.5 \times 5.2 = 2.6$
So, if the number 2 on the
suspension rod is set to 6 on the
vernier scale this will set the
measurement @ 0.8d

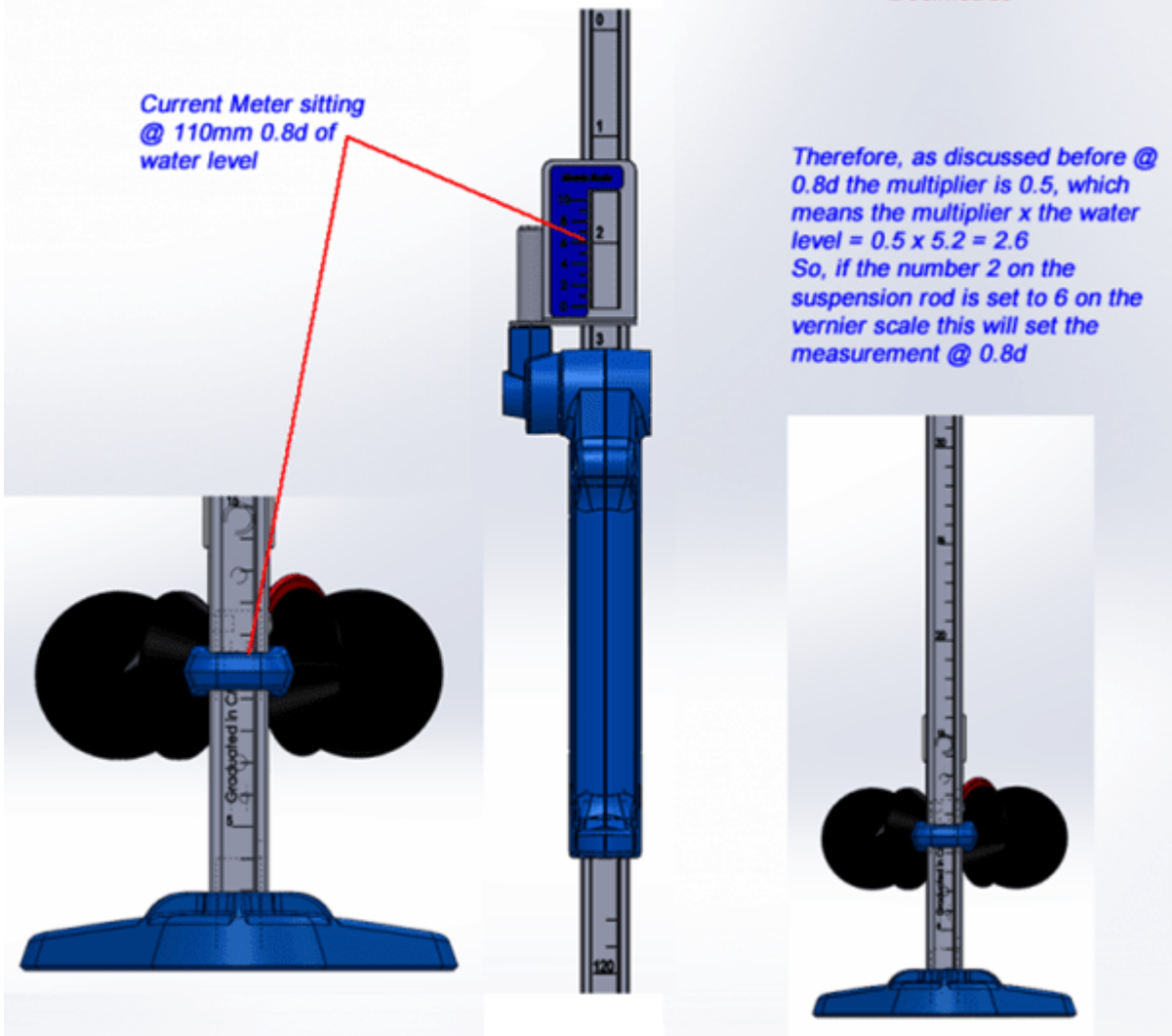

3. Release the trigger.
4. This will position the current meter at 1.1 decimetres (110 mm) on the GRADUATED ROD (0.8 of sounding).

5 Maintenance

Because of the excellent durability of the Top Setting Wading Rods it is only necessary to clean and thoroughly dry the device after use prior to packing away. This is essential to remove any corrosive contaminants that may be present in the water being gauged.

Periodically it may be necessary to remove oxidization from the electrical contact to ensure positive contact. This should be done with superfine emery paper or "scotchbrite" pad.

6 Repair

KISTERS precision instruments and data loggers are produced in quality-controlled processes. All KISTERS production and assembly sites in Australia, New Zealand and Europe are ISO 9001 certified. All equipment is factory tested and/or factory calibrated before it is shipped to the client. This ensures that KISTERS products perform to their fullest capacity when delivered.

Despite KISTERS most rigorous quality assurance (QA), malfunction may occur within or outside of the warranty period. In rare cases, a product may not be delivered in accordance with your order.

In such cases KISTERS' return and repair policy applies. For you as a customer, this means the following:

- Contact KISTERS using the Repair Request Form and the Declaration of Contamination made available online:

Region (Language)	Download Link
Asia-Pacific (English)	Repair Request Form (APAC) Declaration of Contamination (APAC)
Europe, the Middle East and Africa (English)	Repair Request Form (EMEA) Declaration of Contamination (EMEA)
Germany (German)	Repair Request Form (DE) Declaration of Contamination (DE)

In response you will receive a reference number that must be referenced on all further correspondence and on the freight documents accompanying your return shipment.

- Please provide as much information and/or clear instructions within the return paperwork. This will assist our test engineers with their diagnosis.
- Please do not ship the goods prior to obtaining the reference number. KISTERS will not reject any equipment that arrives without reference number; however, it may take us longer to process.

Custom requirements for items sent to KISTERS for warranty or non-warranty repairs: Check with your national customs/tax authorities for details, processes and paperwork regarding tax exempt return of products. Typically, special custom tariff codes are available (such as HS Code = 9802.00) that verify the item is being returned for repair and has no commercial value. Please note that the customs invoice / dispatch documents should also clearly state: "Goods being returned to manufacturer for repair - No Commercial value". It is mandatory to have any returned goods accompanied by a commercial invoice on headed paper. KISTERS reserves the right to charge the customer for time spent rectifying incorrect customs documents.

Note: Please ensure that your goods are packed carefully and securely. Damage that occurs during transit is not covered by our warranty and may be chargeable.

For more information, see the following subsections:

- [Part List](#)²⁰

6.1 Part List

Graphical Part List:

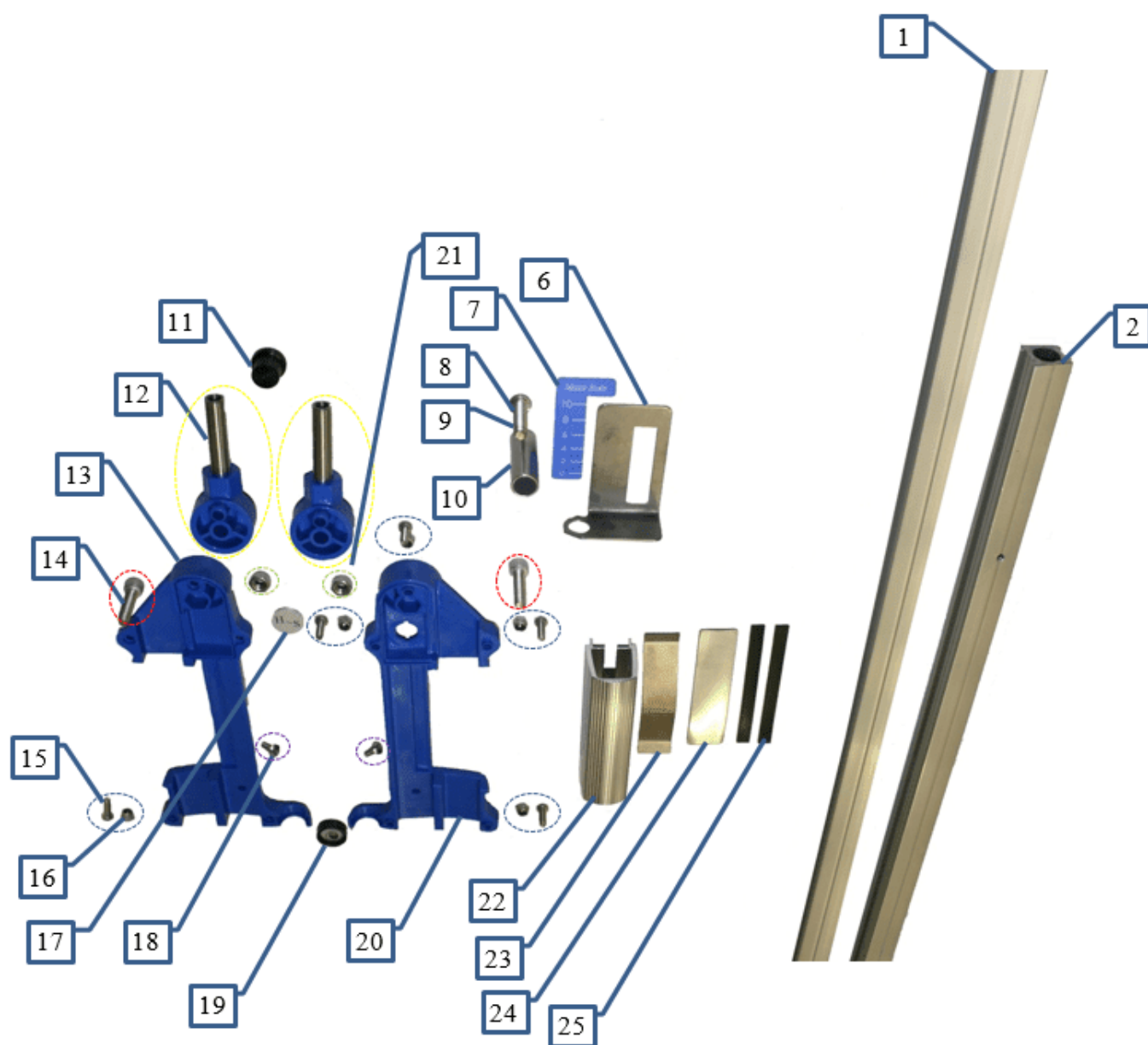

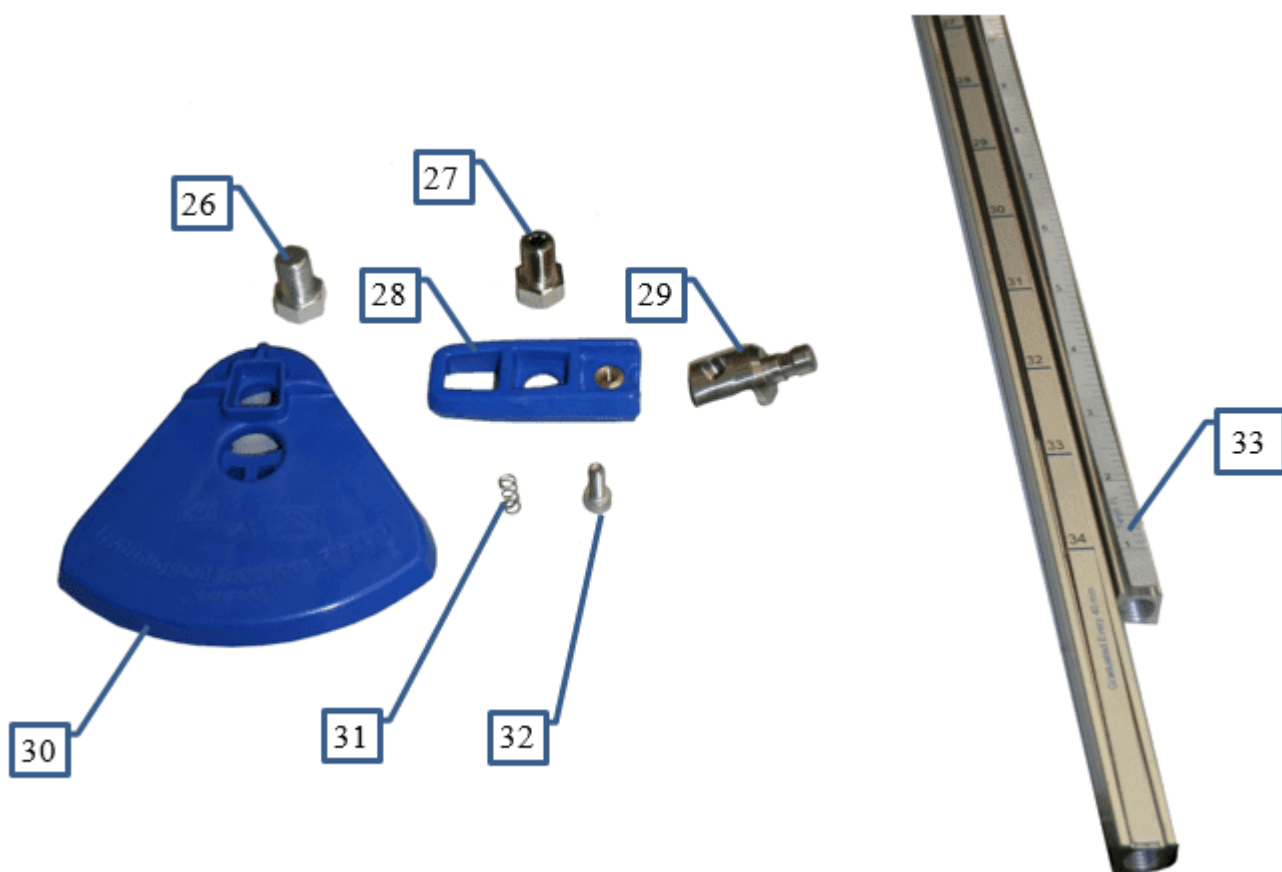

ID.	Part no.	Description	Qty	Remark
1	TSRA04-01	Scale rod	1	
2	MAG04-02	Ruler rod	1	
6	TSRA02-03	Metric Scale Bracket	1	
7	TSRA02-05	Metric Scale label	1	
8	SC065-45	Washer	1	
9	SC057-01	Screw	1	
10	TSRA02-07	Label Bracket Retainer	1	
11	TSRA04-04	Rod End Plug	1	
12	MAG01-07	Adjustment Hub	1	
13	MAG02-07	Handle Left	1	
14	SC045-93	SOC HD Screw	2	
15	SC016-24	Cheese HD Screw	5	
16	SC008-79	Nyloc Nut	5	

ID.	Part no.	Description	Qty	Remark
17	TSRA02-04	HS TAG	1	
18	SC045-92	Screw	2	
19	SC023-145	Bubble Level	1	
20	MAG02-08	Handle Right	1	
21	SC045-92	Nyloc Nut	2	
22	MAG02-05	Handle Grip	1	
23	MAG02-03	Handle Trigger	1	
24	MAG02-09	Handle Support Plate	1	
25	MAG02-04	Rubber Sleeve	2	
26	MAG04-03	Foot Plate and Rod Bolt	1	
27	MAG04-03	Foot Plate and Rod Bolt	1	
28	MAG05-03	Knuckle and Brass Insert	1	
29	MAG05-01	Current Meter Adaptor	1	
30	MAG09-01	Foot Plate	1	
31	MAG05-02	Spring for Earth	1	
32	SC045-50	Screw	1	
33	MAG02-02	Metric Ruler (1 cm Graduation)	1	

7 Technical Data

Material	<ul style="list-style-type: none"> ▪ Rod: Constructed of Anodised Aluminium & Acrylonitrile Styrene Acrylate (ASA) to withstand harsh environment and UV stress. ▪ Meter Adaptors: Stainless Steel & Acrylonitrile Styrene Acrylate (ASA) to withstand harsh environment and UV stress. ▪ Graduations Rulers: <ul style="list-style-type: none"> ▪ Reference Ruler: Anodised aluminium with 3M VHB tape, Metric graduated every 10 mm, numbered in black every 50 mm and numbered in red every 100 mm. ▪ Slide Ruler: Anodised aluminium with 3M VHB tape, Metric graduated and numbered every 40 mm. ▪ Vernier Scale: Stainless Steel Bracket with UV-stabilized Vinyl Label (Metric)
Dimensions	1200 × 124 × 80 mm
Weight	3.5 kg

8 Obligations of the Operator and Disposal

This chapter contains the following subsections:

- [Obligations of the Operator](#)^[24]
- [Dismantling / Disposal](#)^[24]

8.1 Obligations of the Operator

European Union

In the Single European Market it is the responsibility of the operator to ensure that the following legal regulations are observed and complied with: national implementation of the framework directive (89/391/EEC) and the associated individual directives, in particular 2009/104/EC, on minimum safety and health requirements for the use of work equipment by employees at work.

Worldwide

Regulations: If and where required, operating licences must be obtained by the operator. In addition, national or regional environmental protection requirements must be complied with, regardless of local legal provisions regarding the following topics:

- Occupational safety
- Product disposal

Connections: Local regulations for electrical installation and connections must be observed.

8.2 Dismantling / Disposal

When disposing of the units and their accessories, the applicable local regulations regarding environment, disposal and occupational safety must be observed.

Before dismantling

- Electrical Devices:
 - Switch off the units.
 - Disconnect electrical appliances from the power supply, regardless of whether the appliances are connected to the mains or to another power source.
- Mechanical devices:
 - Fix all loose components. Prevent the device from moving independently or unintentionally.
 - Loosen mechanical fastenings: Please note that appliances can be heavy and that loosening the fastenings may cause them to become mechanically unstable.

Disposal

Operators of old appliances must recycle them separately from unsorted municipal waste. This applies in particular to electrical waste and old electronic equipment.

Electrical waste and electronic equipment must not be disposed of as household waste!

Instead, these old appliances must be collected separately and disposed of via the local collection and return systems.

Integrated or provided batteries and accumulators must be separated from the appliances and disposed of at the designated

collection point. At the end of its service life, the lithium-ion battery must be disposed of according to legal provisions.

EU WEEE Directive

















As players in the environmental market, KISTERS AG is committed to supporting efforts to avoid and recycle waste. Please consider:

- Avoidance before recycling!
- Recycling before disposal!



This symbol  indicates that the scrapping of the unit must be carried out in accordance with Directive 2012/19/EU. Please observe the local implementation of the directive and any accompanying or supplementary laws and regulations.

Contact Data

Europe	KISTERS Europe	 +49 2408 9385 0
		 hydromet.sales@kisters.eu
		 www.kisters.eu
Australia	KISTERS Australia	 +612 9601 2022
		 sales@kisters.com.au
		 www.kisters.com.au
New Zealand	KISTERS New Zealand	 +64 7 857 0810
		 sales@kisters.co.nz
		 www.kisters.co.nz
Latin America	KISTERS Latin America	 +57 350 575 4079
		 sales@kisters-latam.com
		 www.kisters-latam.com
North America	KISTERS North America	 +1 561 459 4876
		 kna@kisters.net
		 www.kisters.net
Spain	KISTERS Ibérica	 info@kisters.es
		 www.kisters.es

