

# HS40C

User Manual

# Table of Contents

I	Disclaimer	3
II	Safety Instructions	4
Part I	Introduction	5
1.1	Product Overview .....	6
Part II	Installation	8
2.1	Power Connection .....	8
2.2	Extending the Battery Cables .....	8
2.3	Adjusting the Bubble Rate .....	10
2.4	WL3100 Connection .....	11
Part III	Operation	12
3.1	Control Valve .....	12
3.2	Startup Sequence .....	12
3.3	Tank Pressurisation & Mist Separator Flushing .....	12
3.4	Battery Size .....	13
3.5	Battery Voltage .....	13
Part IV	Maintenance	15
4.1	Automatic Moisture Extraction .....	15
4.2	Filter Maintenance .....	16
Part V	Troubleshooting	18
Part VI	Repair	19
Part VII	Technical Data	20
Part VIII	Obligations of the Operator and Disposal	22
8.1	Obligations of the Operator .....	22
8.2	Dismantling / Disposal .....	22
Part IX	Appendices	24
9.1	Appendix A Installing Polyethelene Tubing and Orifice Fittings .....	24
9.2	Appendix B Using Pressure to Measure Water Level .....	25
9.3	Appendix C HS40 Compact-DO (Dual Orifice) .....	31
9.4	Appendix D Gas Chamber Orifice Assembly GC01P/SS .....	31
9.5	Appendix E Typical Installations .....	34

# I Disclaimer

The information provided in this manual was deemed accurate as of the publication date. However, updates to this information may have occurred.

This manual does not include all of the details of design, production, or variation of the equipment nor does it cover every possible situation which may arise during installation, operation or maintenance. HyQuest Solutions shall not be liable for any incidental, indirect, special or consequential damages whatsoever arising out of or related to this documentation and the information contained in it, even if HyQuest Solutions has been advised of the possibility of such damages.



Any errors found in any HyQuest Solutions product should be reported to HyQuest Solutions where every effort will be made to quickly resolve the problem.

Copyright Notice: No parts of this work may be reproduced in any form or by any means without the written permission of the publisher. HyQuest Solutions waives copyright for users to print out parts of the documentation in hard copy for their own use only.

Trademark Notice: HyQuest Solutions (HS) and KISTERS products and services referred to in this document are trademarks or registered trademarks of HyQuest Solutions or KISTERS AG. Other product names used may or may not be the trademarks of their respective owners.

© 2020 HyQuest Solutions, a KISTERS Group Company. Any rights not expressly granted herein are reserved.

## II Safety Instructions

- Read the user manual including all operating instructions prior to installing, connecting and powering up the HyQuest Solutions HS40C. The manual provides information on how to operate the product. The manual is intended to be used by qualified personnel, i.e. personnel that have been adequately trained, are sufficiently familiar with installation, mounting, wiring, powering up and operation of the product.
  - Keep the user manual on hand for later reference!
  - If you encounter problems understanding the information in the manual (or part thereof), please consult the manufacturer or its appointed reseller for further support.
  - HyQuest Solutions HS40C is intended to be used in hydrometeorological or environmental monitoring applications.
  - Before starting to work, you have to check the functioning and integrity of the system.
    - Check for visible defects on the HS40C, this may or may not include any or all of the following mounting facilities, connectors and connections, mechanical parts, internal or external communication devices, power supplies or power supply lines, etc.
    - If defects are found that jeopardize the operational safety, work must be stopped. This is true for defects found before starting to work as well as for defects found while working.
  - Do not use the HyQuest Solutions HS40C in areas where there is a danger of explosion.
  - The present user manual specifies environmental/climatic operating conditions as well as mechanical and electrical conditions. Installation, wiring, powering up and operating the HyQuest Solutions HS40C must strictly comply with these specifications.
  - Perform maintenance only when tools or machinery are not in operation.
  - If guards are removed to perform maintenance, replace them immediately after servicing.
  - Never make any electrical or mechanical diagnostics, inspections or repairs under any circumstances. Return the product to the manufacturer's named repair centre. You can find information on how to return items for repair in the relevant section of the HyQuest Solutions website.
-  Disposal instructions: After taking the HyQuest Solutions HS40C out of service, it must be disposed of in compliance with local waste and environmental regulations. The HyQuest Solutions HS40C is never to be disposed in household waste!
-  Inputs and outputs of the device are protected against electric discharges and surges (so-called ESD). Do not touch any part of the electronic components! If you need to touch any part, please discharge yourself, i.e. by touching grounded metal parts.

# 1 Introduction

Thank you for choosing our product. We hope you will enjoy using the device.

HyQuest Solutions manufactures, sells, installs and operates quality instrumentation, data loggers and communication technology. Products are designed with passion for environmental monitoring and with a deep understanding of the quality, accuracy and robustness needed to fulfil the requirements of measurement practitioners in the field.

The present User Manual will help you understand, install and deploy the device. If, however, you feel that a particular information is missing, incomplete or confusing, please do not hesitate to contact us for further support!

The HS40 Compact Gas Purge Compressor + Bubbler System has been designed to replace a conventional nitrogen gas bottle supply to a bubble unit/gas purge system, used for measuring water level in dams, rivers, canals and tanks with up to 40 mH<sub>2</sub>O (130 ft) head with a maximum river-line length of 200 m (650 ft). (Note: 50 mH<sub>2</sub>O (160 ft) available on request)

The basic system consists of an air compressor, a 0.75 litre receiving tank, an advanced membrane dryer, micro mist separator (with optional V-series auto purge valve for the micro mist separator), a highly reliable mechanical differential bubbler system, bubble rate check function, high quality Australian made compressor pump packaged into a small but robust metal enclosure. The system incorporates a mechanical pressure switch to maintain a 400kPa (58 psi) - 750 kPa (110 psi) tank pressure to ensure powerful river line purging during site visits.



The HS40 Compact, with the optional inbuilt WL3100 pressure transducer, allows the measurement of water level to an accuracy of  $\pm 0.02\%$  F.S. (The WL3100A is an advanced model that allows the fine tuning of the “user factor” relationship between pressure and water level, and is temperature compensated from  $-40\text{ }^{\circ}\text{C}$  to  $80\text{ }^{\circ}\text{C}$ ) The inbuilt WL3100 / WL3100A have an SDI-12 interface and a 4 - 20 mA interface that can be used at the same time to provide data to 2 separate systems if required.

Advantages over other systems:

- Compact single unit.
- Low maintenance (no gas bottle or desiccant to be replaced) two stage air drying system incorporating micro-mist separator and self-purging membrane dryer to ensure clean dry air is available in all conditions. A yearly check of the internal filter element is recommended, however up to three years before replacement is possible depending on site conditions. (Low cost replacement elements can be purchased from HyQuest Solutions when required.)
- Can interface WL3100 to SDI-12 and 4 - 20 mA outputs simultaneously.
- Easy to install.

There are various models available:

HS40AFC	Includes compressor tank air dryer bubbler.
HS40AFC/2100	Compressor/bubbler above with inbuilt 2100 pressure transducer.
HS40AFC/3100	Compressor/bubbler above with inbuilt WL3100 pressure transducer.

HS40AFC/3100A	Compressor/bubbler above with inbuilt WL3100A pressure transducer. (Full operation down to -40 °C)
.../DI	Above model + dual instrument port feature.
.../DO	Above model + dual orifice feature.
.../V	Above model + auto purge of stainless micro mist separator.

## 1.1 Product Overview

The Model HS40 Compact is designed to replace conventional Dry Nitrogen bubbler systems for water level measurement. The standard unit operates up to 40 m (130 ft) head of water (and up to 50 m (160 ft) upon request). The system is low maintenance and has a low average power consumption.

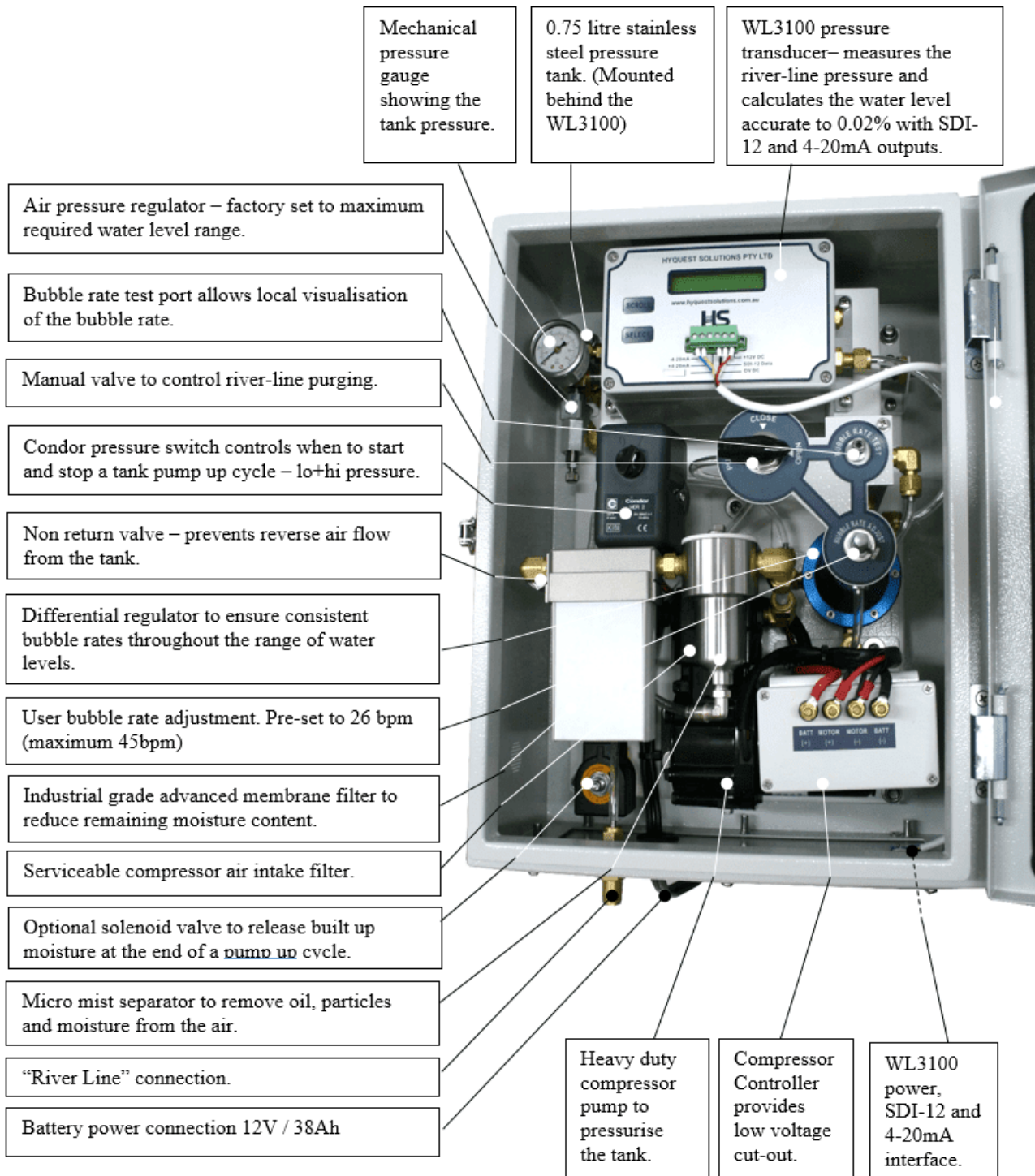

## 2 Installation

The HS40 Compact **MUST** be mounted in a vertical position (not laying flat as shown). The micro mist separator and auto purge moisture feature will not function properly if the unit is mounted in a horizontal position.

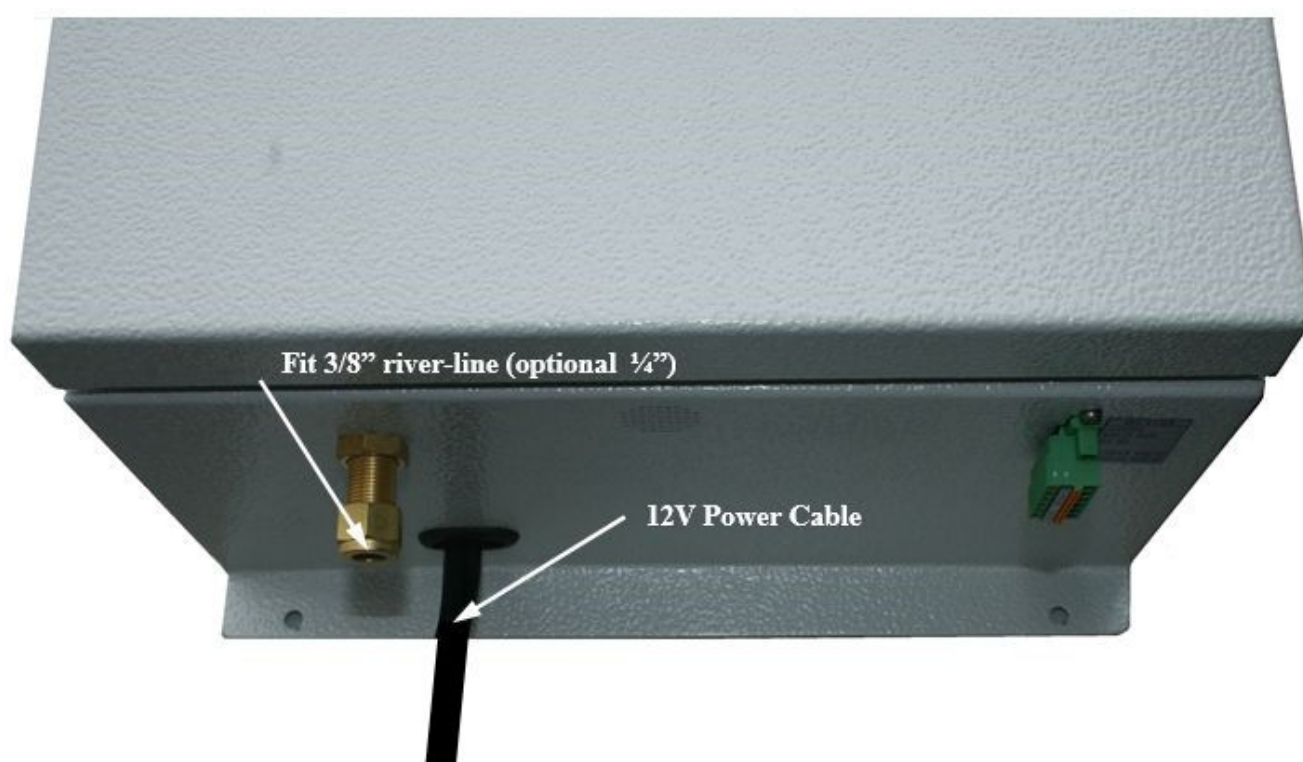

Before connecting 12V power to the HS40 Compact, fit the 3/8 inch river-line where shown (optional ¼ inch fitting).

Connect the 12V DC battery directly to the power cable shown, and add a mains or solar charger if required.

If the tank pressure is less than 400kPa (58psi) [ $\pm 20\%$ ], the compressor will start and pump the tank pressure up to 750kPa (110psi) [ $\pm 20\%$ ]. This initial pump up cycle will take approximately 10 secs.

This chapter contains the following subsections:

- [Power Connection](#)
- [Extending the Battery Cables](#)
- [Adjusting the Bubble Rate](#)
- [WL3100 Connection](#)

### 2.1 Power Connection

The 6 mm<sup>2</sup> power cable provided must be connected **directly** to the power source – either a 12 V / 38 Ah (min) battery OR a 12 V to 13.8 V power supply rated at 40 A. When the compressor operates it will draw about 20A black Thomas pump (or 30Amps for the previous blue ARB pump).

### 2.2 Extending the Battery Cables

The HS40 Compact is supplied with a 2 m power cable, with each core being 6 mm<sup>2</sup>. If the user needs to extend this cable, extreme caution should be exercised, because whenever high currents are drawn through cables, there will be voltage drops!

With the supplied cable (2 m of 6 mm<sup>2</sup>) there is a 0.18 V drop on each conductor when the compressor draws 30 A (worst case for the previous blue ARB pump). Since there is a positive and negative wire, the voltage seen by the HS40 Compact



is  $2 \times 0.18 \text{ V} = 0.36 \text{ V}$  less than the voltage seen at the battery terminals - and at 30 A (again worst case) the battery voltage will also droop. (This is before the cables are extended.)

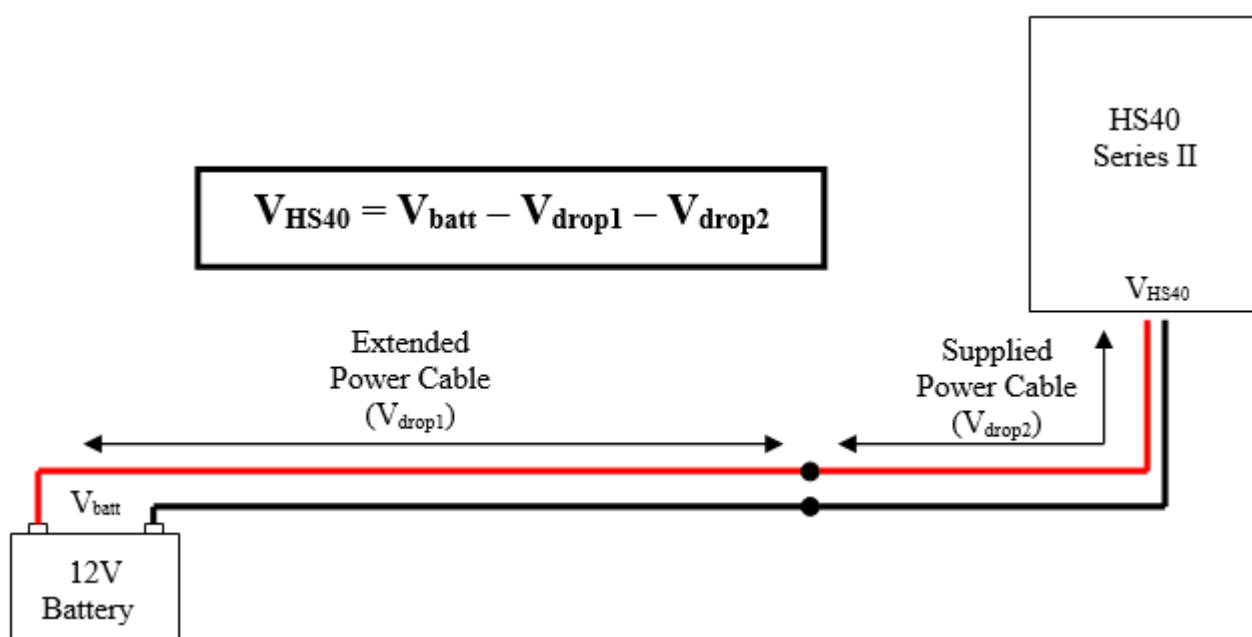

Use the following table to get an idea of the total cable voltage drop - keeping in mind the HS40 Compact will disconnect the compressor when the voltage “it sees” drops below 10 V.

Extended Length	Cable	Cable Size (mm <sup>2</sup> / AWG)	Vdrop1 on extended cable	Vdrop2 on supplied cable	Total Vdrop	Actual when Compact disconnects compressor	Vbatt HS40
2 m (6 ft)		6 / 9.5	0.36 V	0.36 V	0.72 V	10.72 V	
4 m (12 ft)		6 / 9.5	0.72 V	0.36 V	1.08 V	11.08 V *	
6 m (18 ft)		6 / 9.5	1.08 V	0.36 V	1.44 V	11.44 V *	
4 m (12 ft)		10 / 7	0.42 V	0.36 V	0.78 V	10.78 V	
6 m (18 ft)		10 / 7	0.6 V	0.36 V	0.96 V	10.96 V	
10 m (30 ft)		10 / 7	1.02 V	0.36 V	1.38 V	11.38 V *	
15 m (45 ft)		10 / 7	1.50 V	0.36 V	1.86 V	11.86 V *	
15 m (45 ft)		16 / 5	0.96 V	0.36 V	1.32 V	11.32 V *	
20 m (60 ft)		16 / 5	1.26 V	0.36 V	1.62 V	11.62 V *	

\* => Not Recommended

**Note:** A minimum battery capacity of 38 Ah is recommended, to lessen the battery voltage drop under heavy load.

## 2.3 Adjusting the Bubble Rate

- Set the River Line control valve to the “Close” position.
- Attach the HS23QC (supplied as an option) to the HS40 Compact Test Port and immerse the HS23QC in a beaker of water.
- Allow up to 10 minutes for the bubble rate and differential regulator to stabilize.
- Undo the bubble rate locking screw and adjust the bubble rate (to say 21 bubbles/min) The bubble rate at the Test Port will indicate the expected River Line rate at the orifice. Nip up the lock screw and check the bubble rate again - it may change slightly when the lock screw is done up. **CAUTION: ADJUSTMENT OF THE BUBBLE RATE HIGHER THAN THE MAXIMUM 45 BPM WILL VOID THE MANUFACTURER WARRANTY ON THIS PRODUCT.**
- **Disconnect the HS23QC from the HS40 Compact Test Port.**
- Rotate the River Line control valve from the “Close” position to the “Open” position to direct the bubbles from the “Test Port” back to the “River Line”.
- **(Please note leaving the purge valve in the closed position for more than 30 seconds after removing the HS23QC could expose the transducer element to excessive pressure, damaging the element)**

Actual Bubble Rate setting at Test Orifice or River Line (bubbles/min)	Suitability
10 Bubbles Per Minute (Recommended for GC01P/SS)	Suitable for Slow rising streams
16 Bubbles Per Minute	
21 Bubbles Per Minute	
26 Bubbles Per Minute <b>Factory Set Rate (Recommended for BU07)</b>	For medium rising streams
Maximum do not exceed 45 Bubbles Per Minute	Suitable for Fast rising streams
<b>EXCEEDING THE MAXIMUM BUBBLE RATE WILL CAUSE EXCESIVE WEAR TO COMPRESSOR PUMP</b>	

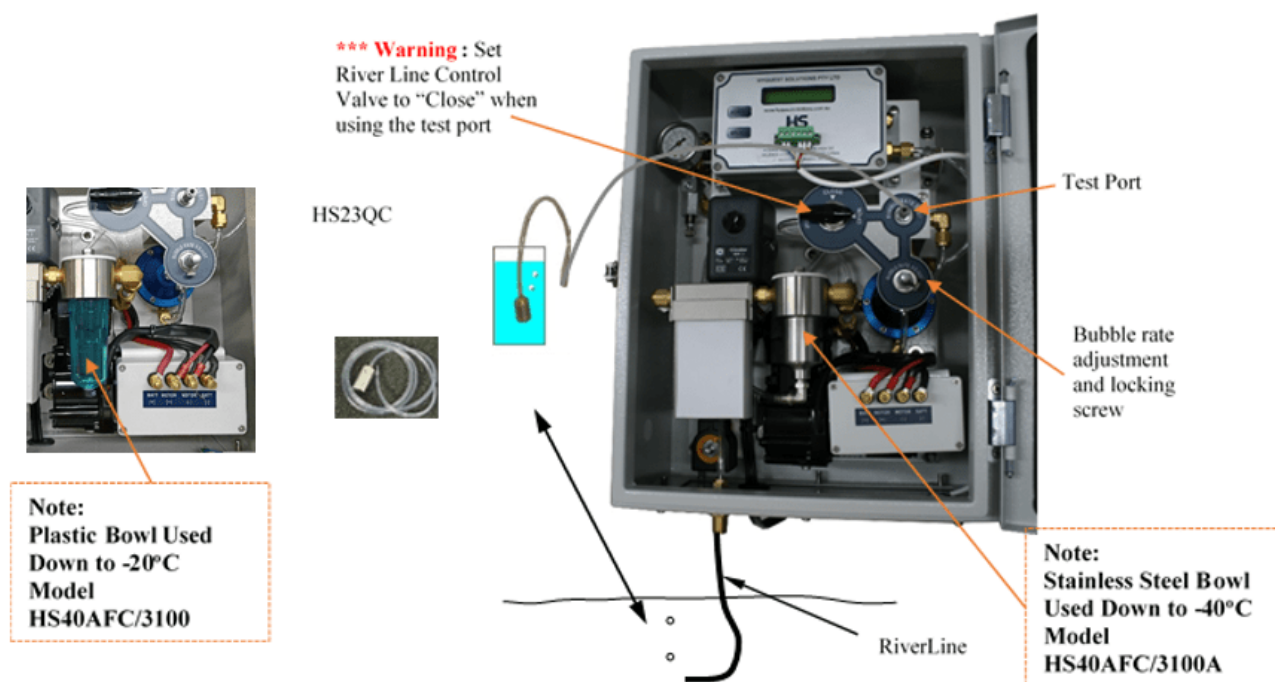

## 2.4 WL3100 Connection

12	+12V DC Power
Da	SDI-12 Data
0V	0V DC Power
+S	+ve 4-20mA Signal
-S	- ve 4-20mA Signal

The WL3100 measures the river-line pressure and provides water level information. Wiring connections to the WL3100 are via a 6 way plug-in terminal block underneath the HS40 Compact enclosure. You **must** have +12V and 0V power for the WL3100 to operate. You may connect the SDI-12 and the 4-20mA interfaces at the same time. (These terminals are “screwless” and keep a constant tension on the wire, thus producing a more reliable connection - simply use a screwdriver to push on the orange lever to release the terminal spring tension, to insert or remove the wire.)

You may connect the WL3100 to the same battery used to power the compressor, but it is advised to cable it directly back to the battery - so that any voltage drops that occur down the compressor power cables, are not seen by the WL3100.

(Consult the WL3100 Manual for a detailed description of the WL3100 connection, operation and specific SDI-12 commands - available on the HyQuest Solutions website)

If connecting to the 4-20mA interface, make sure that the data logger (or RTU) powers up the 4-20mA loop long enough for the WL3100 to recognise it, take a measurement and put the result back on to the 4-20mA loop. (1 sec when “Sampling Mode” is set to “Contin+Avg X” and 15 secs when “Sampling Mode” is set to “Single”)

### 3 Operation

This chapter contains the following subsections:

- [Control Valve](#) <sup>[12]</sup>
- [Startup Sequence](#) <sup>[12]</sup>
- [Tank Pressurisation & Mist Separator Flushing](#) <sup>[12]</sup>
- [Battery Size](#) <sup>[13]</sup>
- [Battery Voltage](#) <sup>[13]</sup>

#### 3.1 Control Valve

The River Line Control Valve has 3 positions:

“Open”	In the Open position, the bubbler (regulator) is open to the River Line port and the transducer.
“Close”	In the Close position, the bubbler (regulator) is closed to the River Line. (If there is nothing plugged into the Test Port Quick Connect, the transducer pressure will continue to increase very slowly as the regulator reacts to a closed system - <b>DO NOT</b> leave it in this position for extended periods as the internal pressure build up may exceed the burst pressure of the transducer element !!!!) <b>Note:</b> The cabinet door has an interlock that prevents the door from being closed while the valve is in the “Close” position.
“Purge”	In the Purge position, the receiver tank is directly connected to the River Line port to allow a Purge of the River Line. After a River Line Purge is performed, rotate the control valve back to the Close position and wait until the River Line pressure drops to a normal level (say 10 seconds) before rotating the control valve back to the Open position. (Otherwise the Purge pressure may be introduced to the transducer and cause damage!!!)

**IMPORTANT: When purging, STOP when the tank pressure falls below 400kPa, otherwise the river-line pressure may fall below the water head pressure resulting in water entering the River Line!**

#### 3.2 Startup Sequence

After power is first applied, the compressor will turn on if the tank pressure is below 400 kPa.

#### 3.3 Tank Pressurisation & Mist Separator Flushing

When the tank pressure falls below 400kPa (58psi) [±20%], the Condor pressure switch will close, causing the controller to turn on the compressor and then pump the pressure back up to 750kPa (110psi) [±20%].

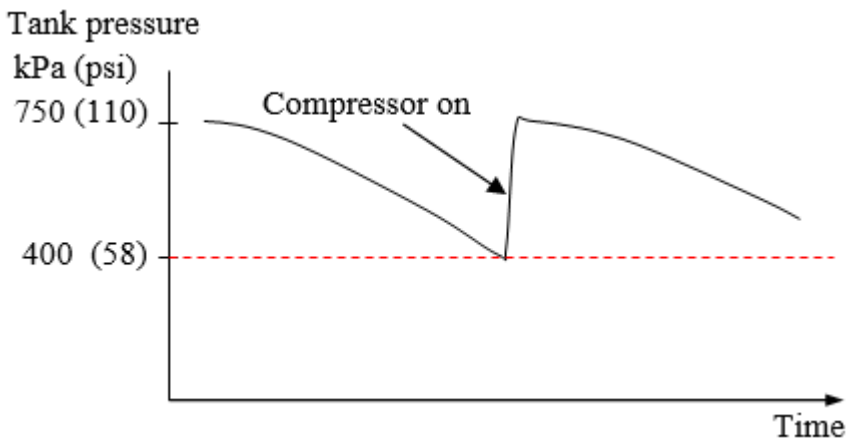



**Note:** Always leave the system with the Condor (pressure) switch manual over-ride in the “1” (on) position!!

### 3.4 Battery Size

The HS40 Compact electronics consumes a quiescent of about 12mA and draws about 20A for 30 secs (black Thomas pump) (30A for 6 secs - blue ARB pump) roughly every 6 hours when the rate at the test orifice is set to 26 bubbles/min delivered to 10m head of water. This averages to:  $20A \times 30\text{secs} / (6\text{hr} \times 3600\text{secs/hr}) = \text{approx } 28\text{mA}$ .

The total average current is therefore:

HS40 Compact quiescent	12.0mA
HS40 Compressor average	28.0mA
WL3100 average	<u>5.0mA</u>
Total consumption	45.0mA

A 38Ah battery will run for approx.  $38\text{Ah} / 45.0\text{mA} = 844 \text{ hrs} = 35 \text{ days} = 1 \text{ month}$

(without any solar or additional charging)

The battery endurance will be dependent on the following:

- The consumption of other equipment connected to the battery.
- The frequency that the system wakes up to take a measurement.
- The length of time the system is awake for each measurement.
- The selected bubble rate - the higher the bubble rate, the more often the compressor will be required to replenish the tank.
- The water depth - the deeper the water, the higher the pressure in each bubble, the more air in each bubble, the more air consumed, the more often the compressor will be required to replenish the tank.
- The battery Ah capacity - the minimum recommended battery capacity is 38Ah.

### 3.5 Battery Voltage

The battery voltage is monitored during all phases of operation. If the battery voltage falls below 10.0V then all compressor operation will stop immediately. The battery voltage must then rise above 12.0V before clearing the battery low condition and restarting the compressor.

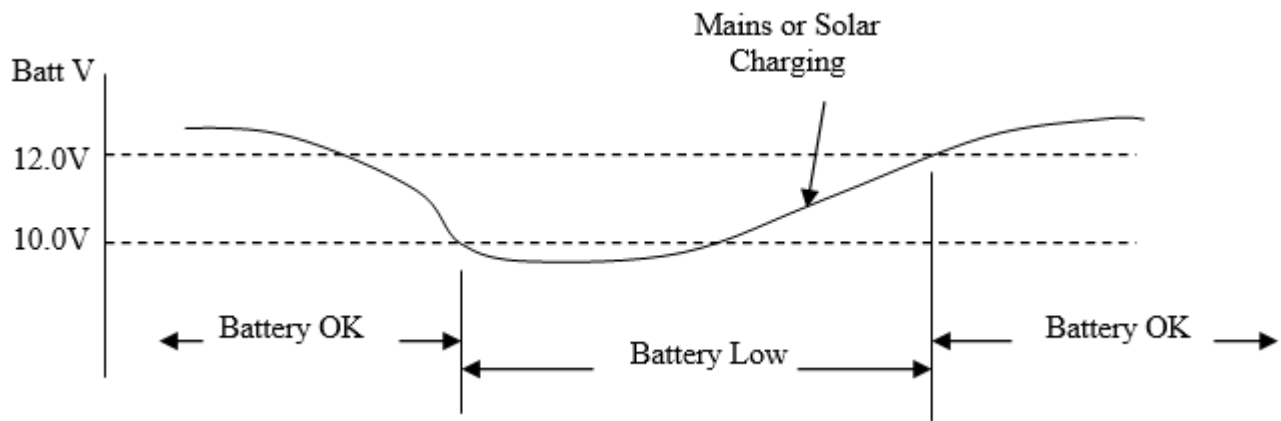

A pump up cycle will be aborted if a battery low condition occurs. This condition is most likely to occur when the compressor is on because it draws approximately 20A when operating - causing the battery voltage to drop.

## 4 Maintenance

The HS40 Compact requires little maintenance, however a yearly check of the micro-mist filter element is recommended to ensure that moisture is being removed from the system effectively. You will also need to ensure that your battery / power supply is sufficient for the equipment that you have installed and that both your battery and charging system are working correctly. (See Specification page).

### Note:

All fittings must be secure.

Even a minor leak will prevent the pressure from being maintained.

For more information, see the following subsections:

- [Automatic Moisture Extraction](#) <sup>15</sup>
- [Filter Maintenance](#) <sup>16</sup>

### 4.1 Automatic Moisture Extraction

All HS40 Compact models have a system that automatically purges any built up moisture in the micro mist separator. As the moisture builds up, it can be seen in the green transparent bowl of the micro mist separator. As the moisture builds, it lifts a float which allows the moisture to drip from the bowl. (An optional system (HS40AFC/3100V) can be requested consisting of a stainless micro mist separator and a solenoid valve which automatically purges out moisture at the end of each pump up cycle.)

## 4.2 Filter Maintenance







**Note:** Reverse step 4 to step 1 to re-assemble.

## 5 Troubleshooting

This fault finding guide should be used by the HS40 Compact user before they consult HyQuest Solutions to assist with specific problems.

<p>HS40 Compact Not Powering Up</p>	<ul style="list-style-type: none"> <li>▪ Check battery voltage.</li> <li>▪ Check battery POWER and GROUND connections to the battery - make sure they are done up tightly and there is no corrosion.</li> </ul>
<p>The compressor doesn't start when I connect the power</p>	<ul style="list-style-type: none"> <li>▪ Check the state of the Condor pressure switch, and make sure it is set to the '1' position.</li> <li>▪ The compressor should only start if the pressure is below 400kPa - or the HS40 power was disconnected before it had reached the 750kPa level (maybe it stopped due to battery LV, or pressure leak and then the battery was disconnected.)</li> <li>▪ Check the battery voltage with your multimeter - if it is below 12V, then maybe the controller locked out the compressor as the voltage fell below 10V, and the voltage has not yet risen above 12V to re-enable the compressor. (Make sure the minimum battery capacity is 38Ah)</li> </ul>
<p>The compressor doesn't start when the pressure falls below 400kPa (58psi).</p>	<ul style="list-style-type: none"> <li>▪ Check the state of the Condor pressure switch, and make sure it is set to the '1' position.</li> <li>▪ Check the battery voltage with your multimeter - if it is below 12V, then maybe the controller locked out the compressor as the voltage fell below 10V, and the voltage has not yet risen above 12V to re-enable the compressor. (Make sure the minimum battery capacity is 38Ah)</li> </ul>
<p>The compressor starts but then cuts out before 750kPa (110psi) is reached.</p>	<ul style="list-style-type: none"> <li>▪ Check the battery voltage with your multimeter - if it dips below 10V while compressor is on, then maybe the battery condition is suspect.</li> <li>▪ Check the voltage on the "POS" and "NEG" stud of the controller - these should be the same as your battery voltage - if the voltage on these studs drops when the compressor turns on (but the battery voltage looks OK), then you are getting a voltage drop somewhere - maybe a loose connection on the battery - or maybe the battery leads are too long or the battery cable gauge is not heavy enough - see section <a href="#">Extending the Battery Cables</a></li> </ul>
<p>The compressor doesn't stop at 750kPa (110psi)</p>	<ul style="list-style-type: none"> <li>▪ There is a fault with the Condor pressure switch adjustment. Contact HyQuest Solutions for the adjustment procedure.</li> </ul>
<p>Can I check the check the pressure transducer calibration through the bubble rate test port ?</p>	<ul style="list-style-type: none"> <li>▪ You may be familiar with this feature in the HS40 Series I or HS40 Series II - but this was removed from the HS40 Compact - so the answer is no, you cannot check the pressure transducer calibration through the bubble rate test port!</li> </ul>

## 6 Repair

HyQuest Solutions precision instruments and data loggers are produced in quality-controlled processes. All HyQuest Solutions production and assembly sites in Australia, New Zealand and Europe are ISO 90001 certified. All equipment is factory tested and/or factory calibrated before it is shipped to the client. This ensures that HyQuest Solutions products perform to their fullest capacity when delivered.

Despite HyQuest Solutions most rigorous quality assurance (QA), malfunction may occur within or outside of the warranty period. In rare cases, a product may not be delivered in accordance with your order.

In such cases HyQuest Solutions' return and repair policy applies. For you as a customer, this means the following:

1. Contact HyQuest Solutions using the Repair Request Form made available online:  
[https://cdn.hyquestsolutions.eu/fileadmin/Services/Downloads/HS-RepairRequestForm\\_EU.pdf](https://cdn.hyquestsolutions.eu/fileadmin/Services/Downloads/HS-RepairRequestForm_EU.pdf)  
In response you will receive a reference number that must be referenced on all further correspondence and on the freight documents accompanying your return shipment.
2. Please provide as much information and/or clear instructions within the return paperwork. This will assist our test engineers with their diagnosis.
3. Please do not ship the goods prior to obtaining the reference number. HyQuest Solutions will not reject any equipment that arrives without reference number; however, it may take us longer to process.

Custom requirements for items sent to HyQuest Solutions for warranty or non-warranty repairs: Check with your national customs/tax authorities for details, processes and paperwork regarding tax exempt return of products. Typically, special custom tariff codes are available (such as HS Code = 9802.00) that verify the item is being returned for repair and has no commercial value. Please note that the customs invoice / dispatch documents should also clearly state: "Goods being returned to manufacturer for repair - No Commercial value". It is mandatory to have any returned goods accompanied by a commercial invoice on headed paper. HyQuest Solutions reserves the right to charge the customer for time spent rectifying incorrect customs documents.

**Note:** Please ensure that your goods are packed carefully and securely. Damage that occurs during transit is not covered by our warranty and may be chargeable.

## 7 Technical Data

Power	
Operating Voltage	12 V DC Nominal
Recommended Battery	12 V DC Sealed Lead Acid (38 Ah)
Low Battery cut-out	10 V DC
Battery recharge recovery	12 V DC
Maximum battery voltage	14.4 V DC
Operation Range	<ul style="list-style-type: none"> <li>▪ Up to 40 m (130ft) of water pressure head</li> <li>▪ (Special request: up to 50 m (160ft) of water pressure head)</li> </ul>
Electronics Quiescent	12 mA (HS40AFC) + 5 mA (WL3100)
Compressor Current	20 Amps for 30 secs every 6 hrs (black Thomas compressor) 26 bubbles/min @ 10mH <sub>2</sub> O (averages to about 28mA) (Previous blue ARB compressor drew 30A)
Average battery consumption	45 mA (with bubble rate set to 26 bubbles/min @ 10 mH <sub>2</sub> O)
Solar	A small 10 Watt solar panel is sufficient to keep the battery fully charged
Maximum Tank / Purge Pressure	750 kPa (110 psi) [±20 %]
Minimum Pump / Purge Pressure	400 kPa (58 psi) [±20 %]
Differential Pressure Regulator	20 kPa to 35 kPa (3 psi to 5 psi)
Bubble Rate	Adjustable from 0 to 45 bubbles / min
Transducer Pressure Connection	1/4 inch tube
River Line Connection	3/8 inch tube (or optional 1/4 inch tube), Dual orifice (2) × 3/8 inch tube (or optional 1/4 inch tube)
Max River-line Length	200 m (600 ft) using 3/8 in OD and 1/8 ID tubing

Air Dryer	Micro mist separator with auto purge solenoid valve and an industrial grade advanced membrane filter
Operating Temperature Range	<ul style="list-style-type: none"><li>▪ -40 °C to +70 °C HS40AFC + HS40AFC / 3100A</li><li>▪ -20 °C to +70 °C HS40AFC/2100 + HS40AFC /3100</li></ul>
Enclosure	Zinc-plated steel enclosure, powder-coated "oyster"
Enclosure Size (H × W × D)	<ul style="list-style-type: none"><li>▪ 490 mm × 330 mm × 210 mm</li><li>▪ 19.3 inch × 13 inch × 8.3 inch</li></ul>
Weight (with built-in WL3100)	20 kg (44 lbs)

## 8 Obligations of the Operator and Disposal

This chapter contains the following subsections:

- [Obligations of the Operator](#) <sup>[22]</sup>
- [Dismantling / Disposal](#) <sup>[22]</sup>

### 8.1 Obligations of the Operator

---

#### *European Union*

---

In the Single European Market it is the responsibility of the operator to ensure that the following legal regulations are observed and complied with: national implementation of the framework directive (89/391/EEC) and the associated individual directives, in particular 2009/104/EC, on minimum safety and health requirements for the use of work equipment by employees at work.

---

#### *Worldwide*

---

Regulations: If and where required, operating licences must be obtained by the operator. In addition, national or regional environmental protection requirements must be complied with, regardless of local legal provisions regarding the following topics:

- Occupational safety
- Product disposal

Connections: Local regulations for electrical installation and connections must be observed.

### 8.2 Dismantling / Disposal

When disposing of the units and their accessories, the applicable local regulations regarding environment, disposal and occupational safety must be observed.

#### **Before dismantling**

- Electrical Devices:
  - Switch off the units.
  - Disconnect electrical appliances from the power supply, regardless of whether the appliances are connected to the mains or to another power source.
- Mechanical devices:
  - Fix all loose components. Prevent the device from moving independently or unintentionally.
  - Loosen mechanical fastenings: Please note that appliances can be heavy and that loosening the fastenings may cause them to become mechanically unstable.

---

#### *Disposal*

---

Operators of old appliances must recycle them separately from unsorted municipal waste. This applies in particular to electrical waste and old electronic equipment.

Electrical waste and electronic equipment must not be disposed of as household waste!

Instead, these old appliances must be collected separately and disposed of via the local collection and return systems.

Integrated or provided batteries and accumulators must be separated from the appliances and disposed of at the

designated collection point. At the end of its service life, the lithium-ion battery must be disposed of according to legal provisions.

---

*EU WEEE Directive*

---

As players in the environmental market, KISTERS AG and HyQuest Solutions are committed to supporting efforts to avoid and recycle waste. Please consider:

- Avoidance before recycling!
- Recycling before disposal!



This symbol  indicates that the scrapping of the unit must be carried out in accordance with Directive 2012/19/EU. Please observe the local implementation of the directive and any accompanying or supplementary laws and regulations.

## 9 Appendices

This chapter contains the following subsections:

- [Appendix A Installing Polyethylene Tubing and Orifice Fittings](#) <sup>[24]</sup>
- [Appendix B Using Pressure to Measure Water Level](#) <sup>[25]</sup>
- [Appendix C HS40 Compact-DO \(Dual Orifice\)](#) <sup>[31]</sup>
- [Appendix D Gas Chamber Orifice Assembly GC01P/SS](#) <sup>[31]</sup>
- [Appendix E Typical Installations](#) <sup>[34]</sup>

### 9.1 Appendix A Installing Polyethylene Tubing and Orifice Fittings

#### General

The polythene tubing (3/8" OD) is available in 100m (SC078-06), 200m (SC078-18) and 300m (SC078-01) rolls. It is an extremely durable material that has been used successfully in this application world wide for many years. The tubing is flexible, easy to handle and can be cut with a knife. The standard copper orifice fitting is comprised of a moulded polythene threaded cap, an orifice outlet and a tube fitting. The moulded cap will screw onto a standard 50mm nominal bore galvanised pipe.

#### Orifice Fittings

The site and reference level for the orifice fittings should be resolved before installation proceeds. The length of tubing from the HS40 Compact to the orifice should not exceed 200 metres. A suggested method for installation of the orifice fitting is shown below. The site of the orifice should be positioned in still water, out of the main stream. The area should be free of silting and aquatic growth. The mounting for the orifice fitting should consist of a section of 50mm nominal bore galvanised pipe threaded at one end and secured at the appropriate reference level. The securing of the orifice mounting should be such that it can withstand the forces applied by the flowing stream and associated floating debris.

#### Preparation of Orifice Tubing

Do not open the carton or remove the strapping. To prepare the roll of tubing for use, cut a 300mm diameter hole in the centre of the cardboard carton, retrieve the end of the tubing from the middle of the coil, then cut the strapping retaining the coil. This method will reduce the possibility of tangling the tubing. Prevent the ingress of dirt etc. from entering the tubing, by taping up the ends. At no time should the open end of the tubing be permitted to contact the soil.

#### Orifice Tubing

It is recommended that a trench be dug (minimum 600mm deep) between the equipment shelter and the proposed positions of the orifice

The trenches should not have any low points in their length, they should have a **continuous fall** to the river.

Pull the free end of the coiled tubing to the orifice position laying the tubing in the trench as you go. Refer to diagrams below.

Remove the protective tape from the end of the tubing, and push the tubing through the 50mm nominal bore pipe mounting. Insert the tubing into the tube fitting on the rear of the orifice fitting, ensuring that both ferrules are in place. Tighten the fitting nut. (Refer to the following diagram for tightening procedure). Place the orifice fitting onto the mounting pipe and tighten. The tubing should be encased in a protective conduit (eg. Polypipe with junction oints installed to allow access in the future.

Cut the tube at the coil end (tape both ends), ensuring that there is sufficient length to make the joint at the HS40S2 within the shelter.

Check the lay of the tubing in the trench to ensure that it is free of coils and kinks. Under no circumstances should the tube form hollows where moisture can be trapped within the tube.

Lay the tubing into position in the equipment shelter as required.

Remove the protective tape from the end of river line tube.

Insert the end of the tube into the appropriate river line fitting on the HS40S2 and tighten both fittings. (Refer to diagram for tightening procedure).



Open the valve to the orifice.

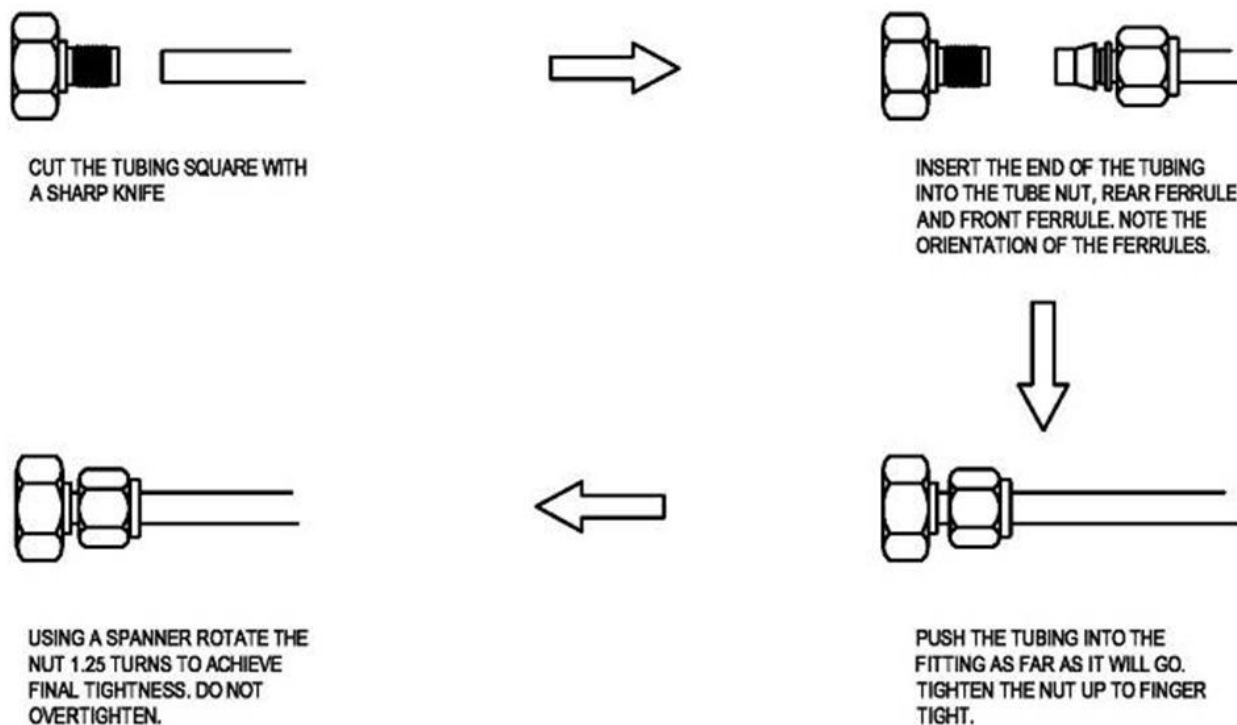

**TYPICAL TIGHTENING PROCEDURE  
FOR RIVERLINE FITTINGS**

## 9.2 Appendix B Using Pressure to Measure Water Level

### Gas Purge Principle

The behaviour of a gas flowing under a variable back pressure is utilised as an accurate means of measuring liquid head.

Provided that:

1. The density of the gas is nearly the same as air.
2. The velocity of gas is low enough so as not to produce significant pressure drop down the line then the system pressure will be equal to the back pressure.

This principle is illustrated in the following series of diagrams.

In the first example, the tube exhausts to atmosphere and hence the water manometer indicate zero pressure in the system because it is acted on by two equal pressures- the system pressure and the atmospheric pressure

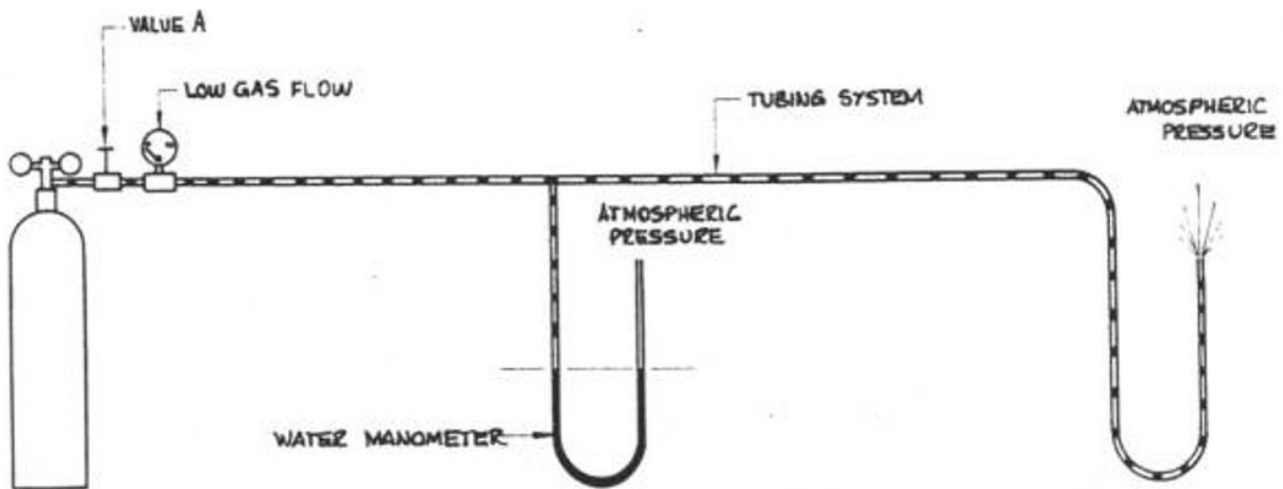

Figure 1 - Depicts first stage in application of gas purge principle

Fig. Depicts first stage in application of gas purge principle [26] - Depicts first stage in application of gas purge principle

Fig. Depicts first stage in application of gas purge principle [26] also illustrate another feature of all pressure systems, namely the gas endeavours to escape through any material that it is in contact with to find a lower pressure, but for practical purposes, the system pressure reflects the lowest of the outlet pressures. In this case, gas endeavours to pass through the walls of the tubing and fittings, through the water, but elects to take the easier path to atmosphere, which is in effect a “massive leak”.

Therefore, it follows that in any pressure system that can exhaust to atmosphere, either through a valve or by a large leak, the system pressure is atmospheric and will not reflect any other pressure.

Provided air or a gas that has a very similar density to air is used, then the errors from this source can be neglected. Nitrogen is preferred as it does not promote the formation of aquatic growth.

The effect of the velocity of the gas can be observed by opening valve A, a higher pressure will be needed to force a high volume of gas through the line, resulting in a pressure drop between valve A and the outlet. Depending on the location of the manometer connection, the manometer will reflect a proportion of this increase in pressure.

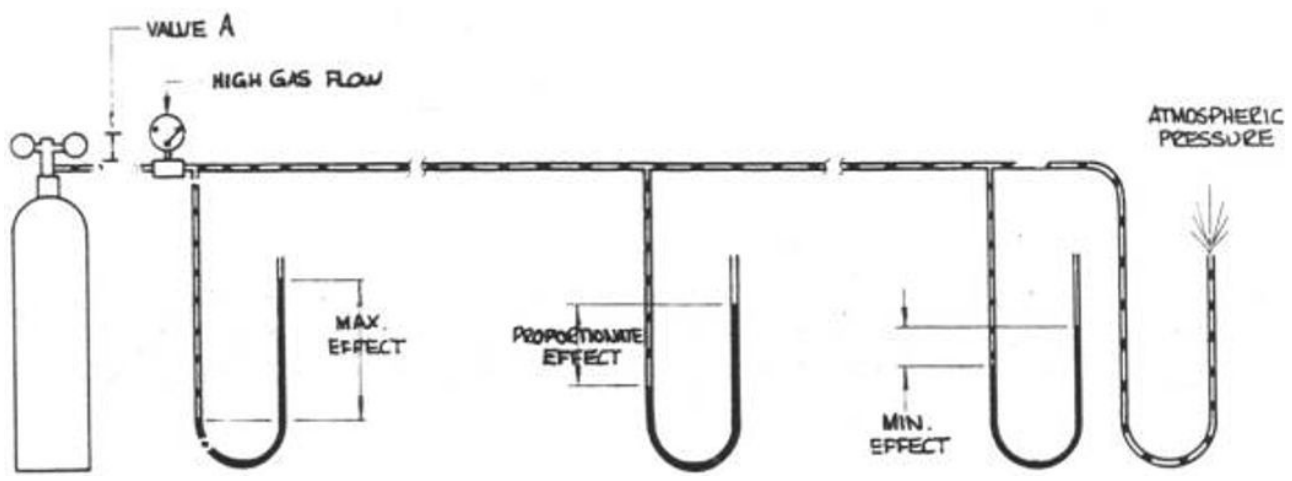

Figure 2 - High gas flow

\* Refer “Bubbler System Instrumentation for Water Level Measurement” – Report of Investigation No. 23 state of Illinois, U.S.A

### Head To Pressure Conversion

As we are not seeking to measure atmospheric pressure, but liquid head, how is the principle applied?

Simply by using two physical characteristics.

1. The tendency of the gas under pressure to “seek” a lower pressure.

2. The ability of a gas to “pass through” liquids.

The first characteristic has already been demonstrated. The second characteristic can be appreciated by blowing through a hollow tube (straw) that is immersed in water. No bubble will appear until the pressure in the tube is sufficient to expel all the water from the tube.

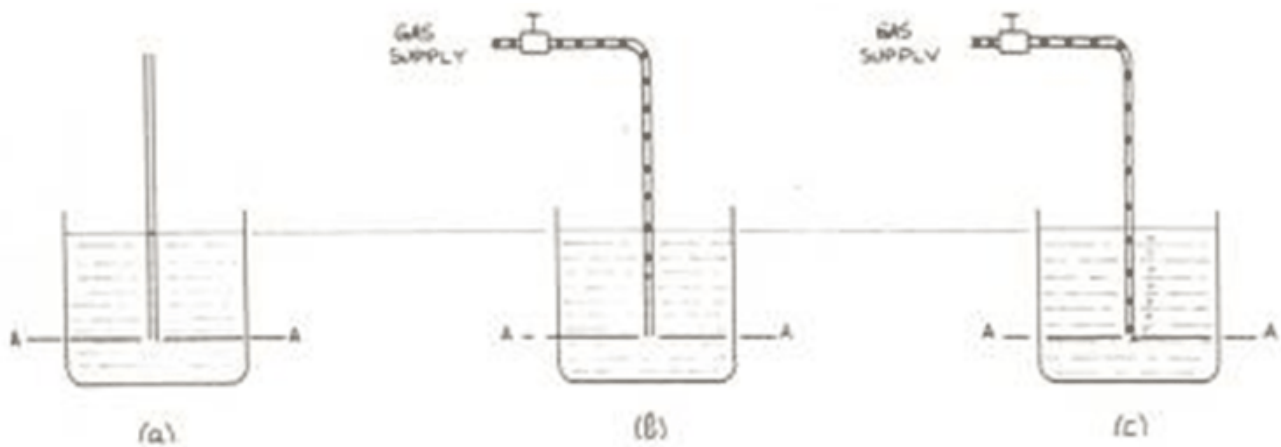
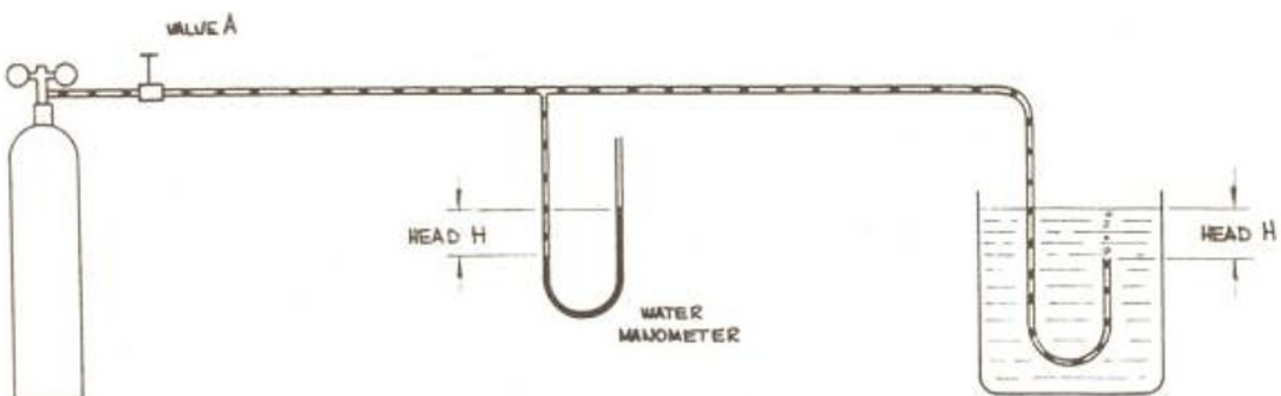

**Figure 3**

- I. If a tube is immersed in a liquid, it can be seen that the pressure at the bottom of the tube is that exerted by the head of liquid above it.
- II. If we connect a gas supply to the tube, the gas will act on the surface of the liquid in the tube and tend to force it down. Assuming there is no change in level, the pressure at the end of the tube must be still the same.
- III. If we increase the pressure so that the gas can push out all the liquid against pressure level A, then it follows that the pressure at A will be the back pressure in the system. Also the pressure of each bubble of gas as it emerges from the end of the tube will at that point have an internal pressure equal to the head, and this internal pressure reduces until the bubble emerges at the surface at atmospheric pressure.

Therefore the gas acts like a plunger to keep the water out of the tube and in effect, precisely balances the head of water that would naturally occur if the tube was opened to atmospheric pressure.

In other words, the system pressure (back-pressure) is supporting a column of water, equal to the pressure head. Hence, any pressure measuring device, if connected to the pressure system will record the pressure head over the tube outlet (orifice).



**Figure 4 - depicts a water manometer connected to the system and it is recommended that - such an arrangement be set up in a workshop for staff training.**

**Gas Purge Operational Characteristics**

In the foregoing, the discussion has been limited to static head conditions, whereas in practice, the levels in stream are constantly fluctuating.

“Rising” Situations

It is the “rising” or “increasing head” situation that is critical for the correct operation system. Consider a situation where the gas supply is cut off and the level rises- refer Fig. With gas supply cut off. Head increased from H1 to H2, gas is forced down the tube by an amount X.

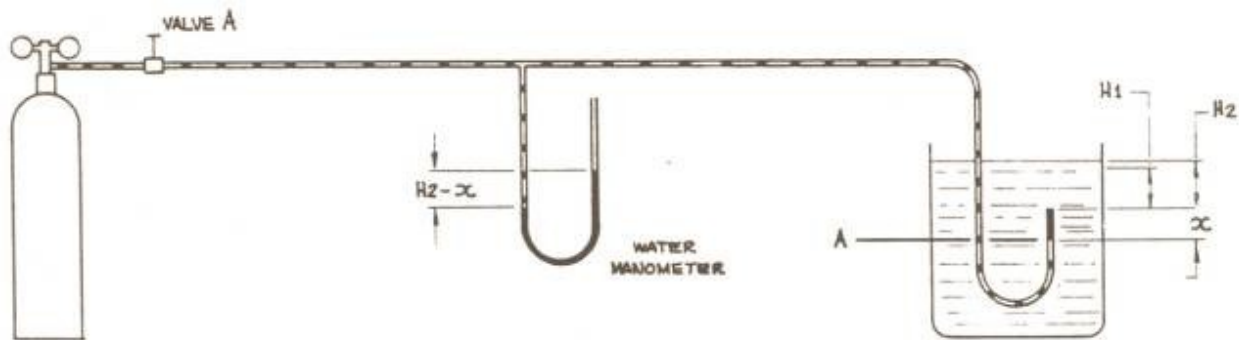

**Figure 5 - With gas supply cut off. Head increased from H1 to H2, gas is forced down the tube by an amount X.**

In this situation, it can be seen that whilst the system pressure has increased, it is not equal to the new head H2, but rather H2-x. This condition will remain as long as the gas is shut off. In other words, we now have a “closed” system, which respond to changes in accordance with universal gas law.

$$\frac{P_i V_i}{T_i} = a \text{ constant}$$

To revert back to the open system, we must restore gas supply, which will eventually build up pressure in the system, until the gas escape from the orifice and the system pressure again becomes the precise head measurement.

The time taken for the pressure system to respond to a given head pressure is commonly referred to as “follow rate”. The normal procedure is to establish the maximum rate of rise to be measured and adjust the gas flow so that there is no significant lag in the pressure system.

However, in order to conserve the gas supply, the flow rate (bubble rate) is set to the minimum that will meet these conditions.

**“Falling” Situation**

The “falling” situation is of course the reverse of the rising situation except that there is now excess pressure in the system. If we were to suddenly lift up the orifice in Fig. 4, the pressure would drop to the new head, seen by the sudden rush of bubbles.

Accordingly, even the lowest bubble rate will suffice for falling conditions.

In practice, it may take some time to the pressure to “bleed away”, but this is usually less than the response time of the sensing unit.

**Field Requirement of Gas Purge Systems**

The principle requirements of gas purge are :

- I. A fine metering valve and sight feed for accurately setting the bubble rate.
- II. Constant regulator to maintain a constant bubble rate with changes of head.
- III. Pressure connections and valves for connecting the tubing to the river and the instrument.

With the overall provision that the unit must be “leak proof”, otherwise the true head will not be recorded.

The configuration most widely used is shown in Fig 6.

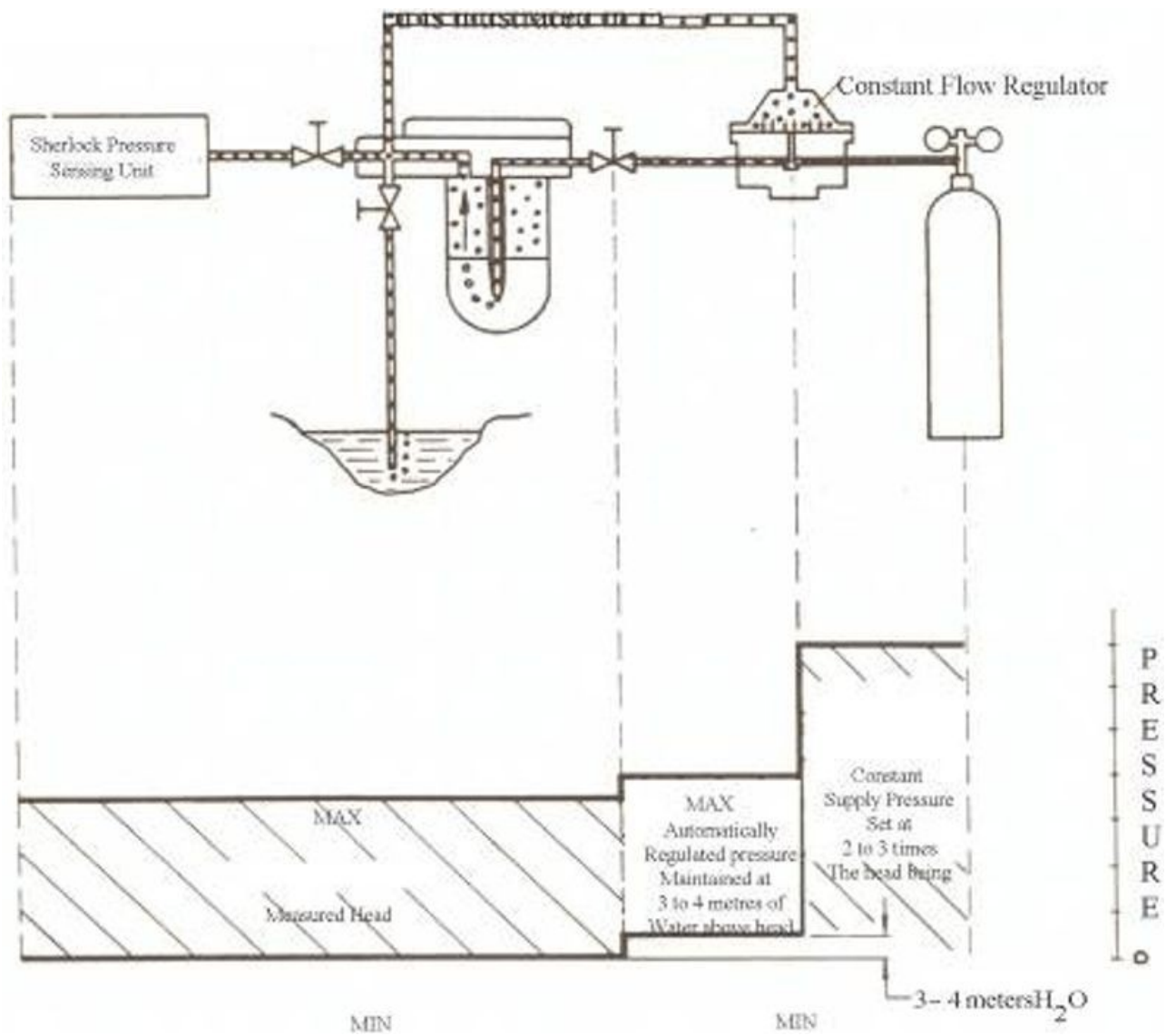

Figure 6 - Diagrammatic view of field gas purge, single line without purge facilities.

### Dual Line Connections

For long line, the effect referred to in Fig. High gas flow<sup>[26]</sup> becomes significant and it is usual to make the connection to the system near the orifice, so in effect there are two lines running the orifice. Hence the term dual line.

The operation of Hyquest Solutions units is described in more details in diagrams 15 and 16 of "instruction Manual for Sherlock Pressure Sensing Units".

### Pressure Bulb or Closed System

The pressure bulb system relies on the normal  $\frac{P_i V_i}{T_i} = \text{constant}$  relationship for gases under pressure.

Using similar diagrams to before, the closed system can be illustrated follows:-

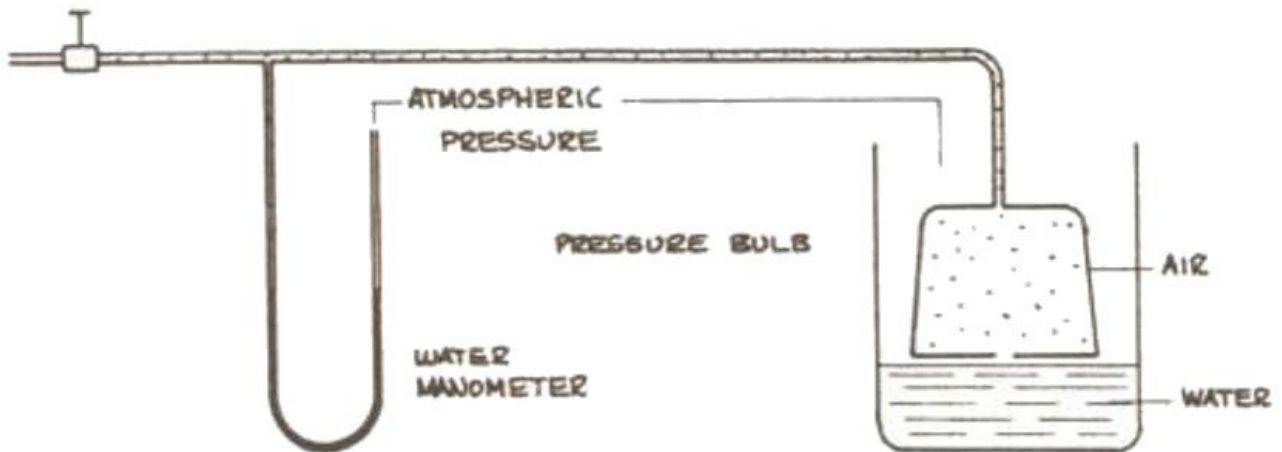

Figure 7 - Atmosphere- up to the level at which the water seals off the bottom of the bulb.

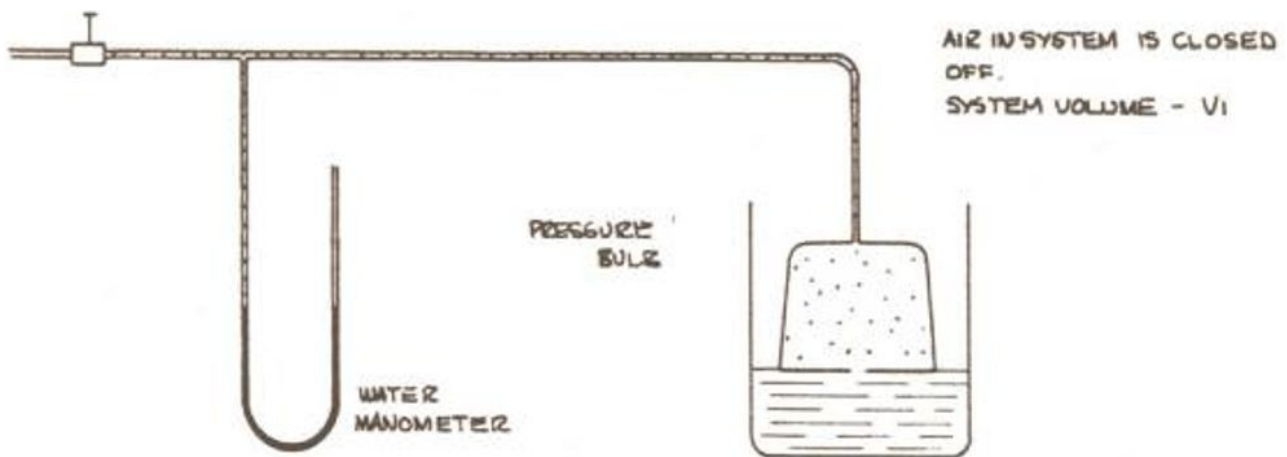

Figure 8 - water seals off air and at this point system pressure is still atmosphere.

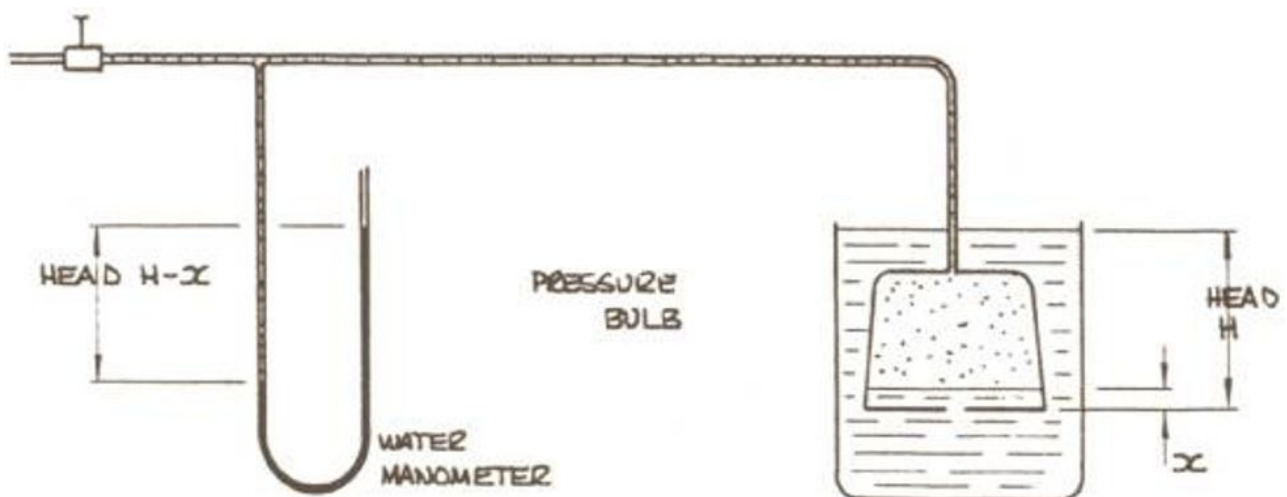

Figure 9: - system operating under head conditions

As the water rises, the system pressure increases to the equivalent of the head  $H$  minus the amount the water rises within the bulb.

This amount  $x$ , is non-linear and therefore cannot be completely compensated for by simple calibration. Provided the head  $H$  does not fall below say 300 mm, error from this cause is minimal.

Basically the closed system will give good results subject to gradual changes of water temperature being experienced and the system being completely gas tight.

A full discussion of this principle is given in "Low Cost Stream Height Recorders" - Unisearch (N.S.W) publication.

### 9.3 Appendix C HS40 Compact-DO (Dual Orifice)

#### Features of Dual Orifice

The Model HS40 Compact-DO comes with a dual orifice application. It consists of 2 orifices located at different heights from the river bed. Under normal conditions the bottom orifice is active and the top orifice is inactive. The dual orifice application becomes beneficial in a situation where severe siltation appears and causes the blockage of the bottom orifice at which instance the valve of the bottom orifice (1) is closed and the valve of the inactive (top) orifice (2) is opened to keep the bubbler system operating.

Another application for the dual orifice system is where higher accuracy is required over a large head, by splitting the head into 2 smaller ranges - and using a transducer with lower range and higher resolution.



**Note:** Only one orifice can operate at a time. If the level of the second orifice exceeds the range of the transducer; the transducer level can be set again at the second orifice.

### 9.4 Appendix D Gas Chamber Orifice Assembly GC01P/SS

#### Step 1:

Secure Socket/Locknut to the 2" BSP pipe

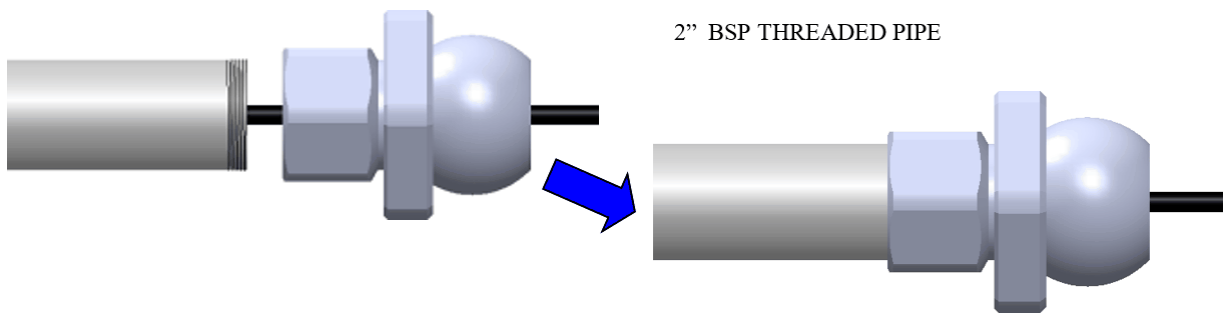

**Step 2:**

Undo the nut and ferrules; feed the tube nut and the two ferrules onto the river line as shown in figure below

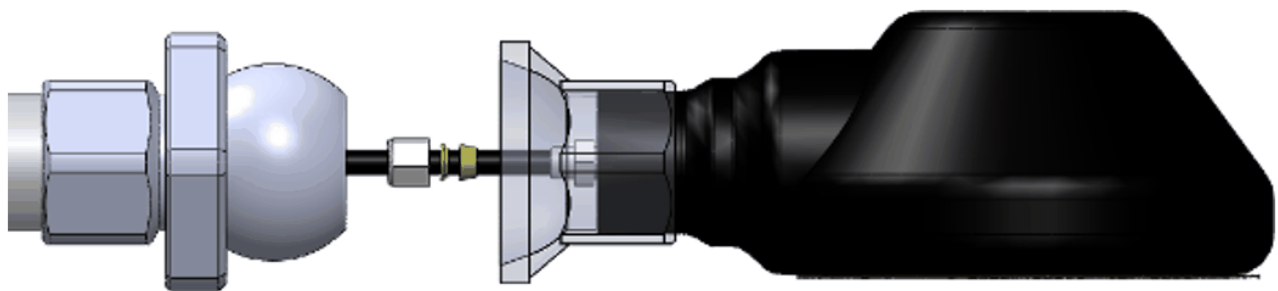

**Step 3:**

Tighten the tube nut to the GCO1 fitting as shown in figure below

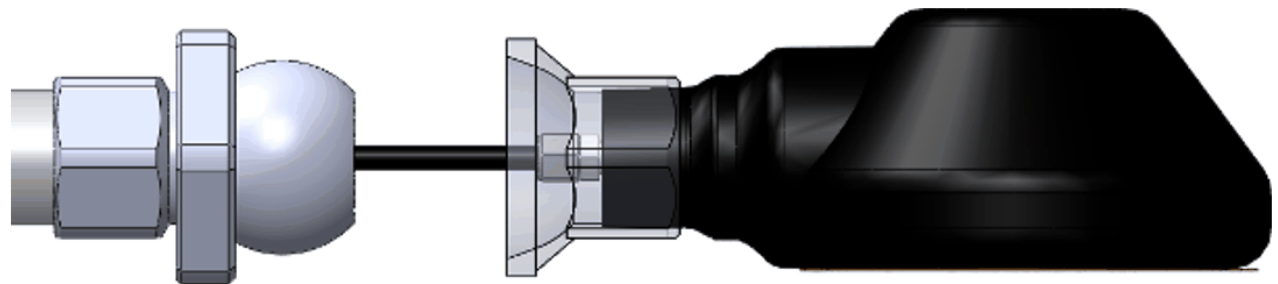

**Step 4:**

Place the GCO1 assembly onto the mounting pipe, adjust coupling so the GCO1 is horizontal to the water, and tighten the flexible coupling with GCO1 in position.

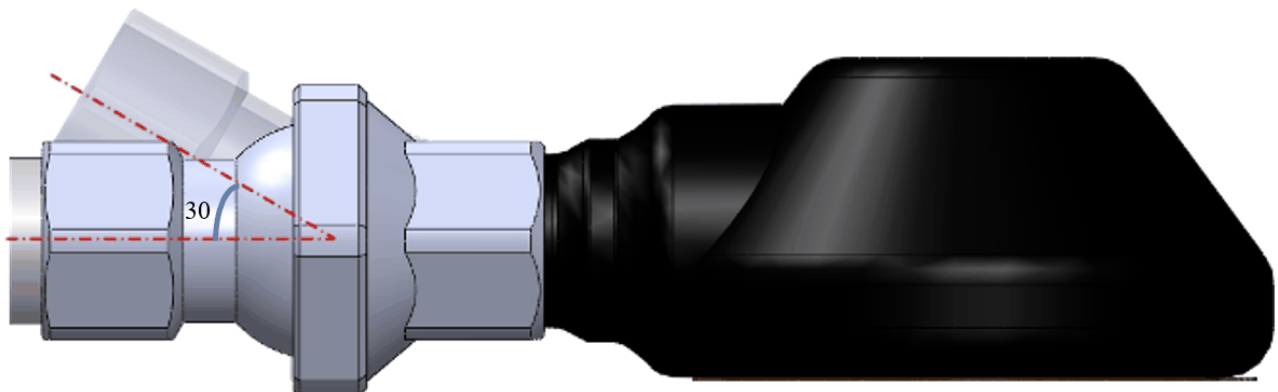

**Note:**



Ensure that the GCO1 is horizontally level as shown. Flexible coupling allows adjustment up to 30 degrees.

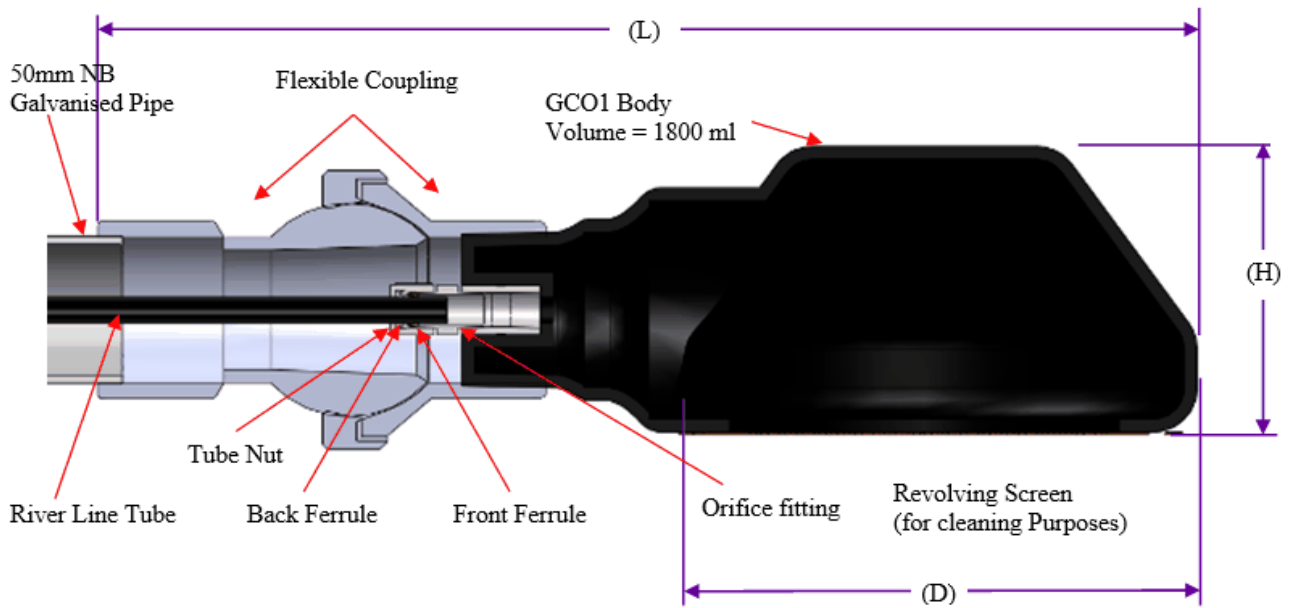

GCO1 DIMENSIONS		
Dimension	Metric (mm)	Imperial (inch)
L	410	16.2
D	210	8.3
H	110	4.3

## 9.5 Appendix E Typical Installations

Typical installation for HS40 Compact & HS40 Compact-DO (Dual Orifice)

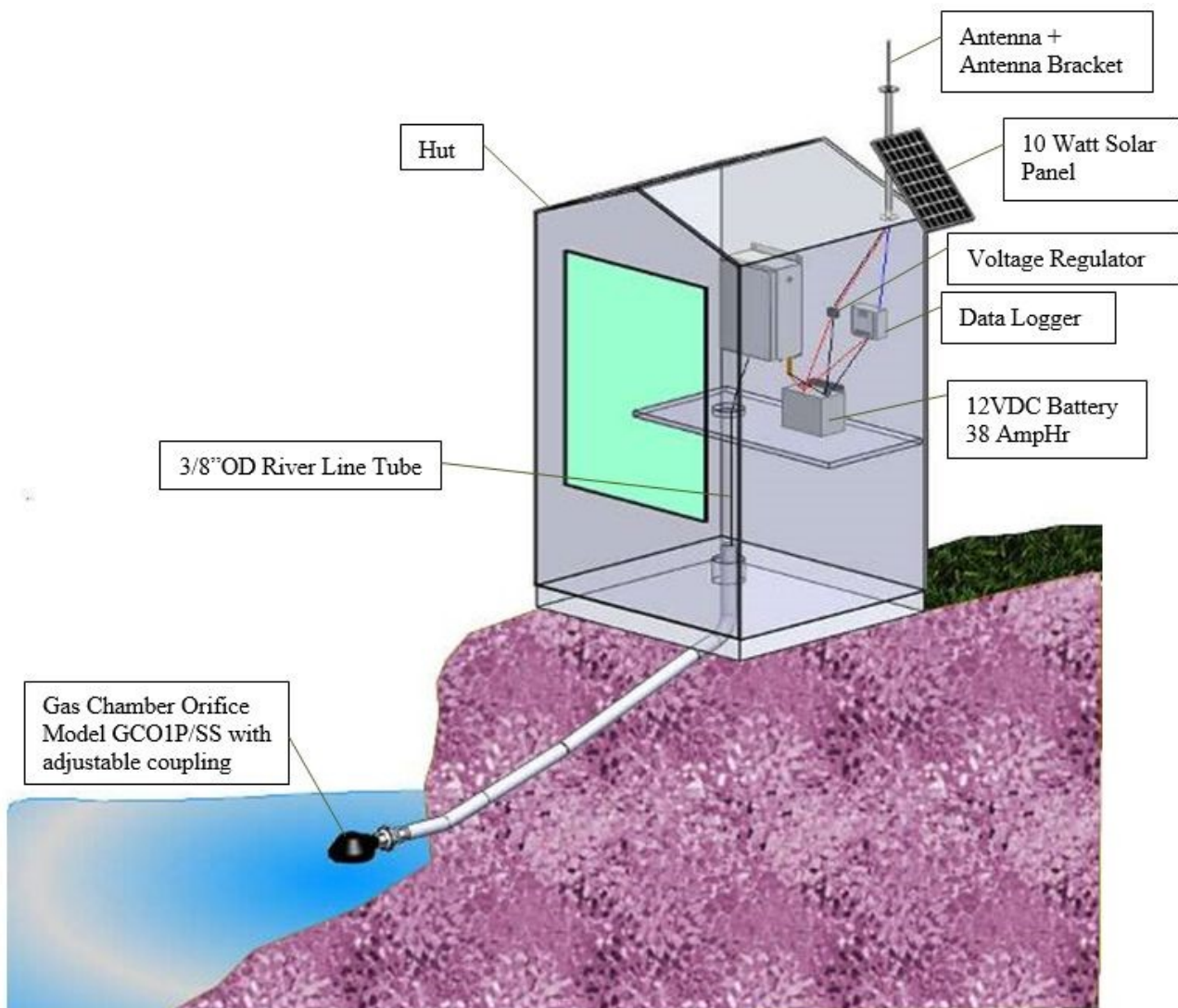



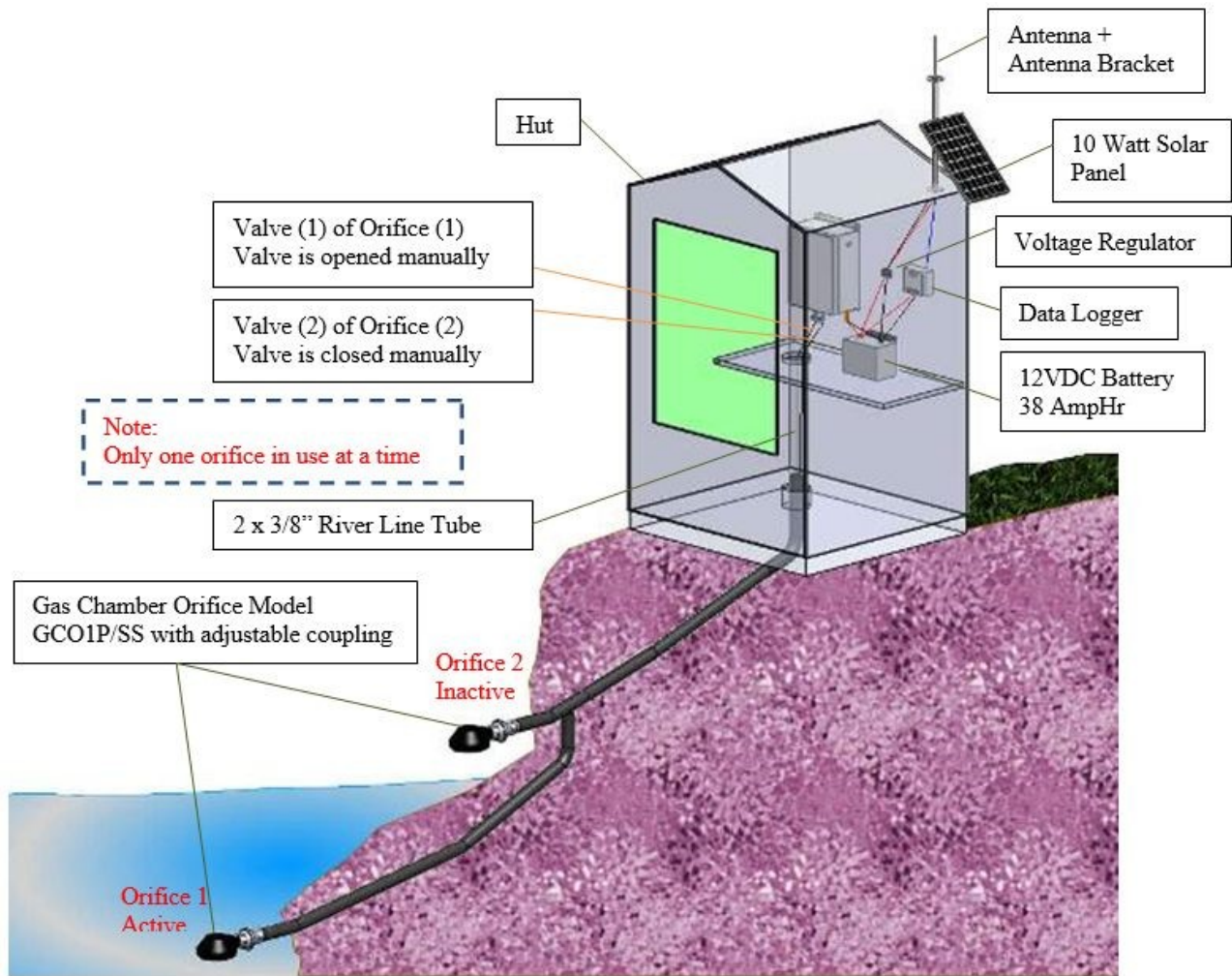











HS40 Compact Typical Installation



HS40 Compact-DO Typical Installation

# Contact Data

<b>Europe</b>	HyQuest Solutions (KISTERS AG)	 +49 2408 9385 0
		 info@hyquestsolutions.eu
		 www.hyquestsolutions.eu
<b>Australia</b>	HyQuest Solutions Pty Ltd	 +612 9601 2022
		 sales@hyquestsolutions.com.au
		 www.hyquestsolutions.com.au
<b>New Zealand</b>	HyQuest Solutions NZ Ltd	 +64 7 857 0810
		 sales@hyquestsolutions.co.nz
		 www.hyquestsolutions.com.au
<b>Latin America</b>	HyQuest Solutions (KISTERS LATAM)	 +57 350 575 4079
		 sales-latam@hyquestsolutions.com
		 www.hyquestsolutions.es
<b>North America</b>	Hydrological Services America LLC (KISTERS Group)	 +1 561 459 4876
		 sales-hsa@kisters.net
		 www.hyquestsolutionsamerica.com

